

**DESCRIPTION**

Solenoid valve 2 way normally closed with assisted-lift diaphragm

**CONSTRUCTION**

Body and cover	Brass
Armature tube	AISI 303
Plunger and core	AISI 430FR
Springs	AISI 302
Seal material	FPM
	NBR (on request)



**FEATURES**

- Maximum allowable pressure PS 16bar<sup>③</sup>
- Maximum fluid viscosity 25cSt (mm<sup>2</sup>/s)
- Ambient temperature: from -10°C to +80°C according to the coil
- Preferred mounting position with vertical coil above

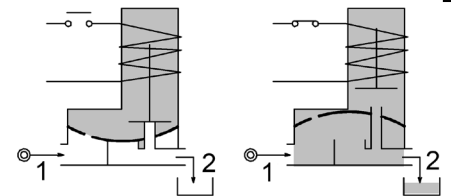
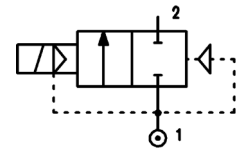

4

- OPTIONS:**
- cUL<sup>®</sup> US certified coils
  - NPT connections
  - ATEX Ex d coils
  - Degreased for use with oxygen

CODE ① ②	Connection G ISO 228	Orifice mm Ø	Kv m <sup>3</sup> /h	Differential pressure bar		Nominal power	Coil		Seal ①	Temp. range °C	
				Min	Max		Series	Width			
E168CV11///...	3/8"	11	1.2	0	14	5	10W	2	30	FPM=V	-10 +140
					-	14	27W	5	36		
E168DV16///...	1/2"	16	2.4	0	14	2.5	10W	2	30		
					-	14	27W	5	36		
E168EV16///...	3/4"	16	2.4	0	14	2.5	10W	2	30		
					-	14	27W	5	36		
E168EV20/H/...	3/4"	20	7.2	0	16	5	10W	2	30		
					-	16	27W	5	36		
E168FV25///...	1"	25	7.2	0	8	-	10W	2	30		
					14	1.5	14W	5	36		
					-	6	27W	5	36		
E168FV25/H/...	1"	25	8.4	0	16	5	10W	2	30		
					-	16	14W	5	36		
E168GV35///...	1"1/4	35	16.2	0	16	-	10W	2	30		
					-	6	14W	5	36		
					-	16	27W	5	36		
E168HV40///...	1"1/2	40	16.8	0	16	-	10W	2	30		
					-	6	14W	5	36		
					-	16	27W	5	36		

① Seal  
 ② Coil  
 ③ The maximum allowable pressure PS for steam 2,5bar (gauge pressure)

COILS ②	Alternating Current 50/60Hz (V)							Direct Current (V)		Electrical connection	Connectors
	12	24	48	110	220 230	240	380	12	24		
Series 2 Width 30-10W	20A	20B	20C	20D	20E	20F	20G	200	201	DIN 43650A	PG9 code 10349000 or PG11 code 10349001
Series 5 Width 36-14W	-	U55B 	-	U55D 	-	U55F 	-	U550 	U551 		
Series 5 Width 36-27W	52A	52B	52C	52D	52E	52F	52G	520	521		

**DESCRIPTION**  
 Insulation class  
 Series 2 =F Series 5=H  
 Voltage tolerance  
 AC +15% -10%  
 DC ± 10%  
 Protection class  
 IP65 with connector fitted  
 IP00 without connector

**OPTIONS**  
 Class H insulation (series 2)  
 Cable attached  
 Special coil voltage  
 Special coil powers  
 certified coils

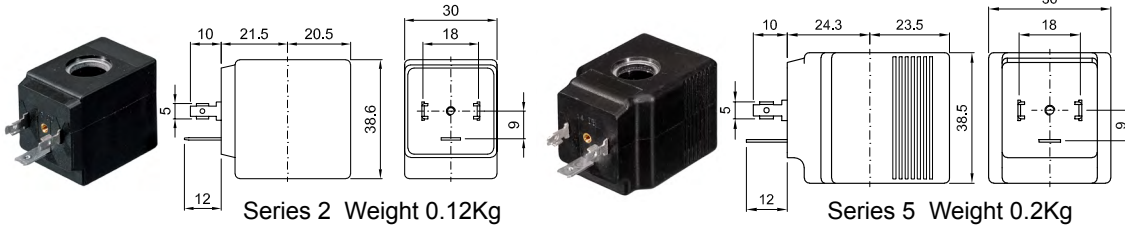

(for coil details see section 8)

### SPARE PARTS LIST

1. Coil
2. Armature tube
3. Armature tube OR
4. Diaphragm assembly+plunger

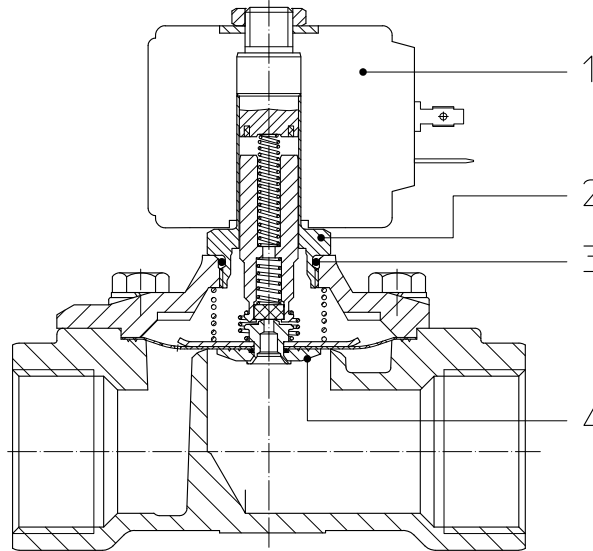

### OVERALL DIMENSION

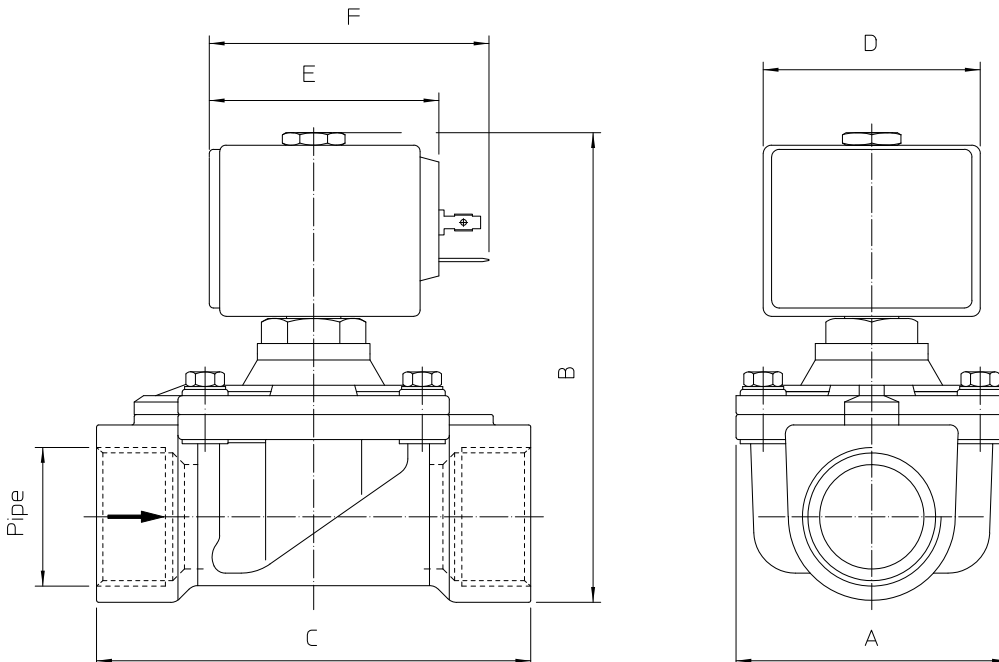

PIPE	A	B	C
G3/8"	50	89	56
G1/2"	50	100	70
G3/4"	50	100	70
G3/4" /H	65	103	104
G1"	65	112	104
G1" /H	65	110	104
G1"1/4	94	130	128
G1"1/2	94	130	128

COIL TYPE	D	E	F
Series 2 30mm	30	42	54
Series 5 36mm	36	48	60