

DESCRIPTION

Solenoid valve 2 way with servo-assisted diaphragm bi-stable.

The bi-stable function is achieved by the use of a polarized permanent magnet energizing the coil with a DC current for at least 15ms in the reverse direction of the previous impulse.



CONSTRUCTION

Body and cover	Brass
Armature tube	AISI 303
Plunger and core	AISI 430FR
Magnet	NeFeB
Springs	AISI 302
Seal material	NBR - FPM - EPDM

FEATURES

- Minimum differential pressure 0.15bar
- Maximum allowable pressure PS 25bar^③
- Maximum fluid viscosity 25cSt (mm²/s)
- Ambient temperature: from -10°C to +80°C according to the coil
- Preferred mounting position with vertical coil above

OPTIONS: Special coil powers

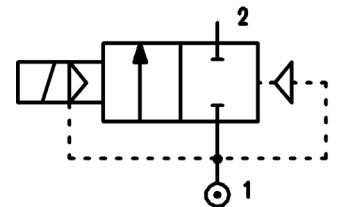

4

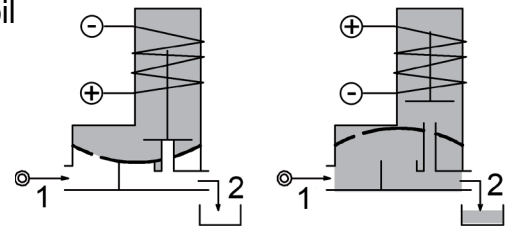

CODE ① ②	Connection G ISO 228	Orifice mm	Kv m ³ /h	Differential pressure bar		Nominal power DC Watt	Coil		Seal ①	Temp. range °C
				Min	Max		Series	Width		
D117B...10///...	1/4"	10	1.5	0.15	8	2	3	22	NBR=B	-10 +90
					15	5				
D117C...10///...	3/8"	10	1.7	0.15	8	2				
					15	5				
D117C...12///...	3/8"	12	2.2	0.15	8	2				
					15	5				
D117D...12///...	1/2"	12	2.5	0.15	8	2				
					15	5				
D117E...18///...	3/4"	18	5.5	0.15	8	2				
					13	5				
D117F...25///...	1"	25	10.2	0.15	8	2				
					10	5				
D117G...30///...	1"1/4	30	15	0.15	8	2				
					10	5				

① Seal Example: D117DB12///301120 NBR seal
 ② Coil Coil 24V DC 2W

③ The maximum allowable pressure PS for steam 2,5bar (gauge pressure)

COILS ②	Direct Current															Electrical connection	Connectors
	3V			6V			9V			12V			24V				
	2W	5W	6.5W	2W	5W	6.5W	2W	5W	6.5W	2W	5W	6.5W	2W	5W	6.5W		
Series 2 Width 30	308120			305120	305150		307120	307150		300120	300150	300	301120	301150	301	DIN 46244	PG9 code 10348000

DESCRIPTION
 Class F insulation
 Voltage tolerance ± 10%
 Protection class
 IP65 with connector fitted
 IP00 without connector
 Continuous service ED100%

OPTIONS
 Class H insulation
 Cable attached
 Special coil voltage
 Special coil powers

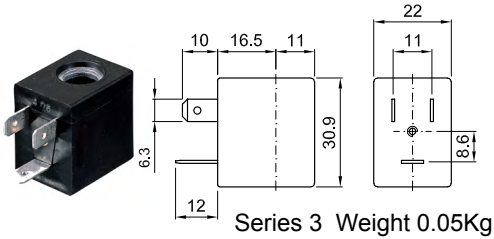

SPARE PARTS LIST

1. Coil fixing nut
2. Coil
3. Plunger
4. Armature tube with core
5. Diaphragm assembly

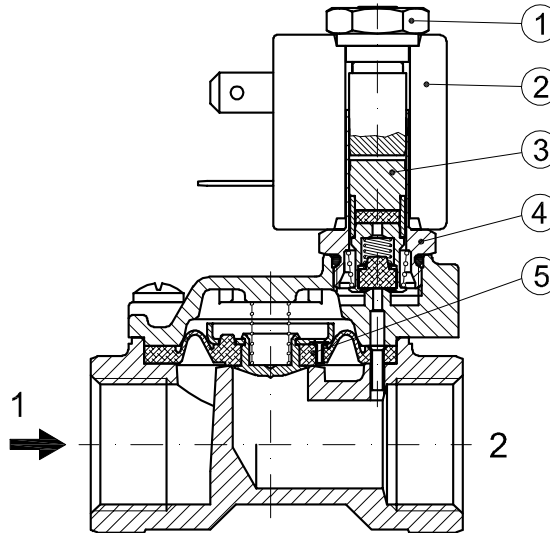

OVERALL DIMENSION

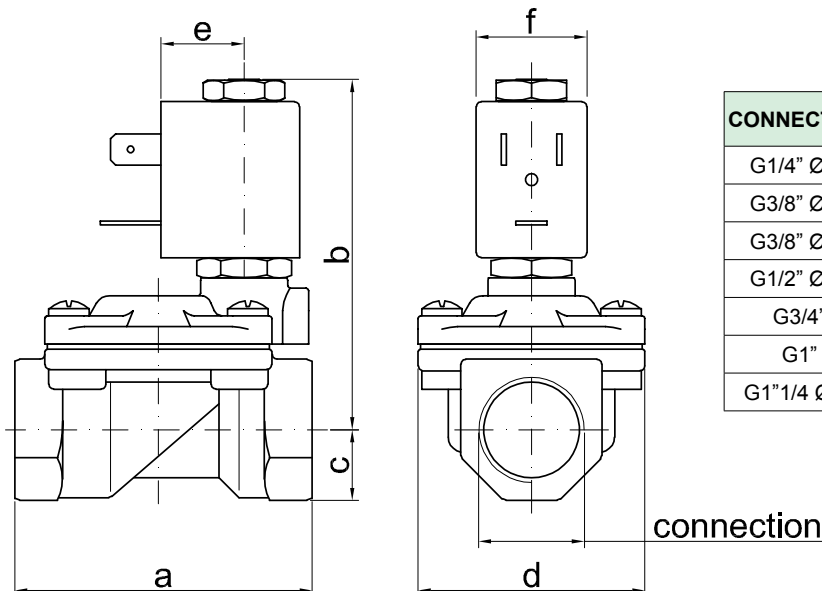

CONNECTION	a	b	c	d	e	f	weight Kg
G1/4" Ø10	49	65	11	32	16	22	0.23
G3/8" Ø10	49	65	11	32	16	22	0.24
G3/8" Ø12	59	70	14	45	16	22	0.42
G1/2" Ø12	59	70	14	45	16	22	0.39
G3/4"	79	76	18	55	16	22	0.65
G1"	96	85	20	72	16	22	1.05
G1"1/4 Ø30	119	92	25	85	16	22	1.70