

Area Gripping Systems FXP

Suction area (LxB) from 442 x 130 mm to 1,432 x 130 mm

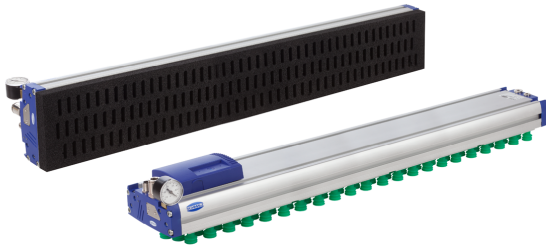

Area Gripping Systems FXP

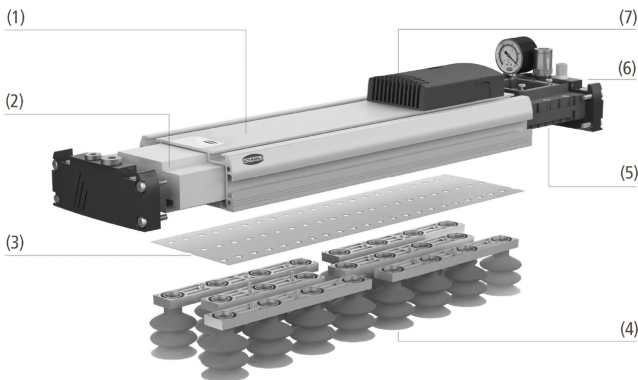

System Design Area Gripping Systems FXP

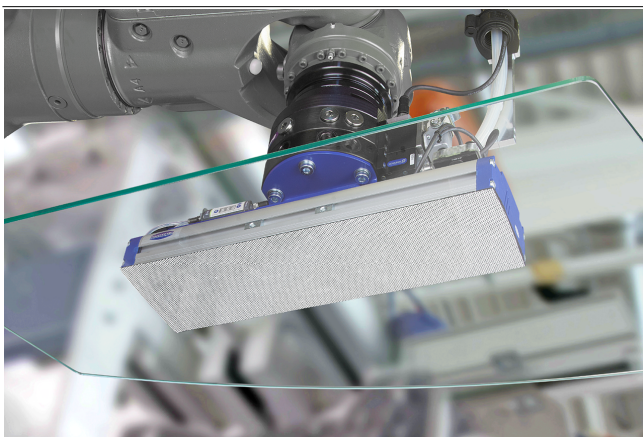

Area gripping system FXP with protective layer SU for handling glass

Suitability for Industry Specific Applications

Applications

- Universal gripper with integrated, pneumatic vacuum generation, for handling workpieces regardless of size, geometry, material and surface
- Handling of workpieces made from various materials, such as wood (coated or rough sawn), packaging (boxes, bags or cans), metal sheets, glass, plastics, CFRP, etc.
- Handling of porous workpieces, workpieces with gaps or undefined pick-up position
- Mark-free handling of sensitive workpieces such as display glass
- Ideal for use on robots due to its low weight

Design

- Aluminum basic profile (1) with side T-slots for sensors and an integrated air supply for separation; different gripper lengths available
- Vacuum booster (2) for quicker evacuation; valve film (3) for the quick change of valve type and size
- Suction cup sealing element (4) with push-in function or sealing foam with adhesive film
- Multi-stage ejector (5) as integrated vacuum generator
- End cover with integrated functions (6): connection for compressed air, vacuum gauges; optional blow off and separation functions
- Silencer (7)

Product Highlights

- Integrated vacuum generator enables shortest cycles; minimal interfering contours
- Vacuum booster integrated in the base profile ensures fast evacuation and short cycles
- Gripper can be optimally adapted to the application thanks to selectable sealing element (suction cups or sealing foam)
- Check valves (SVK) ideal for porous workpieces; flow resistors (SW) for smooth surfaces and swiveling up to 45°
- Intelligent FXP-i version with condition monitoring functions and communication interfaces for monitoring and controlling the entire production process

Area Gripping Systems FXP

Suction area (LxB) from 442 x 130 mm to 1,432 x 130 mm

Designation Code Area Gripping Systems FXP



1 – Abbreviated designation

Code	Version
FXP	Integrated vacuum generator

4 – Length

Code	Length in mm
442	442
640	640
838	838
1234	1234
1432	1432

7 – Sealing element

Code	Height/diameter in mm
O20	Sealing foam (height = 20)
O10O10	Sealing foam (height = 20)
N10	Sealing foam (height = 10)
SPB2-20 P	Suction cup (ø 20)
SPB2-40 P	Suction cup (ø 40)

2 – Control valve

Code	Type
i	IO-Link, with integrated control valves
S	With integrated control valves
-	No control valves

5 – Suction rows

Code	Number
3R	3 suction rows
5R	5 suction rows

8 – Protective layer

Code	Type
SU	Protective layer
-	No protective layer

3 – Valve technology

Code	Type
SW	Flow restrictor
SVK	Check valve

6 – Hole spacing

Code	Spacing in mm
18	18
36	36
54	54

9 – Filter

Code	Type
F	Filter
-	No filter

- Integrated control valves at FXP-S (optional)
- Control of vacuum on/off (24V DC, normally open) and blow off on/off (24V DC, normally closed) on version FXP-S
- Integrated in the end cover
- Electrical connection: M12 plug (4-pole)

Available spare parts: sealing foam (DI-PL), suction cup (SPB2)

Area Gripping Systems FXP

Suction area (LxB) from 442 x 130 mm to 1,432 x 130 mm

Ordering Data Area Gripping Systems FXP

Type (Sealing foam)				Length L [mm]:				
				442	640	838	1,234	1,432
FXP-SW	3R18	O20	-	10.01.38.00685	10.01.38.00686	10.01.38.00687	10.01.38.00688	10.01.38.00689
FXP-SW	3R18	O10010	F	10.01.38.00690	10.01.38.00691	10.01.38.00692	10.01.38.00693	10.01.38.00694
FXP-SW	5R18	O10010	-	10.01.38.00705	10.01.38.00706	10.01.38.00707	10.01.38.00708	10.01.38.00709
FXP-SW	5R18	O10010	F	10.01.38.00710	10.01.38.00711	10.01.38.00712	10.01.38.00713	10.01.38.00714
FXP-SW	5R18	N10SU	-	10.01.38.02947	10.01.38.02948	10.01.38.02949	10.01.38.02950	10.01.38.02951
FXP-S-SW	3R18	O20	-	10.01.38.00908	10.01.38.00909	10.01.38.00910	10.01.38.00911	10.01.38.00912
FXP-S-SW	3R18	O10010	F	10.01.38.00913	10.01.38.00914	10.01.38.00915	10.01.38.00916	10.01.38.00917
FXP-S-SW	5R18	O10010	-	10.01.38.00928	10.01.38.00929	10.01.38.00930	10.01.38.00931	10.01.38.00932
FXP-S-SW	5R18	O10010	F	10.01.38.00933	10.01.38.00934	10.01.38.00935	10.01.38.00936	10.01.38.00937
FXP-S-SW	5R18	N10SU	-	10.01.38.02957	10.01.38.02958	10.01.38.02959	10.01.38.02960	10.01.38.02961
FXP-i SW	3R18	O20	-	10.01.38.06811	-	-	10.01.38.07421	-

Type (Sealing foam)				Length L [mm]:				
				442	640	838	1,234	1,432
FXP-SVK	3R18	O20	-	10.01.38.00675	10.01.38.00676	10.01.38.00677	10.01.38.00678	10.01.38.00679
FXP-SVK	3R18	O10010	F	10.01.38.00680	10.01.38.00681	10.01.38.00682	10.01.38.00683	10.01.38.00684
FXP-SVK	5R18	O10010	-	10.01.38.00695	10.01.38.00696	10.01.38.00697	10.01.38.00698	10.01.38.00699
FXP-SVK	5R18	O10010	F	10.01.38.00700	10.01.38.00701	10.01.38.00702	10.01.38.00703	10.01.38.00704
FXP-SVK	5R18	N10SU	-	10.01.38.02952	10.01.38.02953	10.01.38.02954	10.01.38.02955	10.01.38.02956
FXP-S-SVK	3R18	O20	-	10.01.38.00876	10.01.38.00899	10.01.38.00900	10.01.38.00901	10.01.38.00902
FXP-S-SVK	3R18	O10010	F	10.01.38.00903	10.01.38.00904	10.01.38.00905	10.01.38.00906	10.01.38.00907
FXP-S-SVK	5R18	O10010	-	10.01.38.00918	10.01.38.00919	10.01.38.00920	10.01.38.00921	10.01.38.00922
FXP-S-SVK	5R18	O10010	F	10.01.38.00923	10.01.38.00924	10.01.38.00925	10.01.38.00926	10.01.38.00927
FXP-S-SVK	5R18	N10SU	-	10.01.38.02962	10.01.38.02963	10.01.38.02964	10.01.38.02965	10.01.38.02966
FXP-i-SVK	3R18	O20	-	10.01.38.06676	-	-	10.01.38.06691	-

Type (Suction cup)				Length L [mm]:					
				442	640	838	1,234	1,432	
FXP-SW	5R36	SPB2	20	-	10.01.38.00745	10.01.38.00746	10.01.38.00747	10.01.38.00748	10.01.38.00749
FXP-SW	5R36	SPB2	20	F	10.01.38.00750	10.01.38.00751	10.01.38.00752	10.01.38.00753	10.01.38.00754
FXP-SW	3R54	SPB2	40	-	10.01.38.00725	10.01.38.00726	10.01.38.00727	10.01.38.00728	10.01.38.00729
FXP-SW	3R54	SPB2	40	F	10.01.38.00730	10.01.38.00731	10.01.38.00732	10.01.38.00733	10.01.38.00734
FXP-S-SW	5R36	SPB2	20	-	10.01.38.00968	10.01.38.00969	10.01.38.00970	10.01.38.00971	10.01.38.00972
FXP-S-SW	5R36	SPB2	20	F	10.01.38.00973	10.01.38.00974	10.01.38.00975	10.01.38.00976	10.01.38.00977
FXP-S-SW	3R54	SPB2	40	-	10.01.38.00948	10.01.38.00949	10.01.38.00950	10.01.38.00951	10.01.38.00952
FXP-S-SW	3R54	SPB2	40	F	10.01.38.00953	10.01.38.00954	10.01.38.00955	10.01.38.00956	10.01.38.00957
FXP-i SW	3R54	SPB2	40	-	10.01.38.06812	-	-	10.01.38.07424	-

Type (Suction cup)				Length L [mm]:					
				442	640	838	1,234	1,432	
FXP-SVK	5R36	SPB2	20	-	10.01.38.00735	10.01.38.00736	10.01.38.00737	10.01.38.00738	10.01.38.00739
FXP-SVK	5R36	SPB2	20	F	10.01.38.00740	10.01.38.00741	10.01.38.00742	10.01.38.00743	10.01.38.00744
FXP-SVK	3R54	SPB2	40	-	10.01.38.00715	10.01.38.00716	10.01.38.00717	10.01.38.00718	10.01.38.00719
FXP-SVK	3R54	SPB2	40	F	10.01.38.00720	10.01.38.00721	10.01.38.00722	10.01.38.00723	10.01.38.00724
FXP-S-SVK	5R36	SPB2	20	-	10.01.38.00958	10.01.38.00959	10.01.38.00960	10.01.38.00961	10.01.38.00962
FXP-S-SVK	5R36	SPB2	20	F	10.01.38.00963	10.01.38.00964	10.01.38.00965	10.01.38.00966	10.01.38.00967
FXP-S-SVK	3R54	SPB2	40	-	10.01.38.00938	10.01.38.00939	10.01.38.00940	10.01.38.00941	10.01.38.00942
FXP-S-SVK	3R54	SPB2	40	F	10.01.38.00943	10.01.38.00944	10.01.38.00945	10.01.38.00946	10.01.38.00947
FXP-i-SVK	3R54	SPB2	40	-	10.01.38.06692	-	-	10.01.38.06693	-

Area Gripping Systems FXP

Suction area (LxB) from 442 x 130 mm to 1,432 x 130 mm

Ordering Data Spare Parts Area Gripping Systems FXP

Type (Sealing foam)			3R18	3R18 F	5R18	5R18 F
DI-PL	442	O20	10.01.38.00113	-	-	-
DI-PL	442	O10010	-	10.01.38.00192	10.01.38.00864	10.01.38.00622
DI-PL	442	N10SU	-	-	10.01.38.02863	-
DI-PL	640	O20	10.01.38.00405	-	-	-
DI-PL	640	O10010	-	10.01.38.00408	10.01.38.00865	10.01.38.00627
DI-PL	640	N10SU	-	-	10.01.38.02864	-
DI-PL	838	O20	10.01.38.00140	-	-	-
DI-PL	838	O10010	-	10.01.38.00409	10.01.38.00866	10.01.38.00628
DI-PL	838	N10SU	-	-	10.01.38.02865	-
DI-PL	1,234	O20	10.01.38.00193	-	-	-
DI-PL	1,234	O10010	-	10.01.38.00196	10.01.38.00867	10.01.38.00629
DI-PL	1,234	N10SU	-	-	10.01.38.02866	-
DI-PL	1,432	O20	10.01.38.00406	-	-	-
DI-PL	1,432	O10010	-	10.01.38.00410	10.01.38.00868	10.01.38.00630
DI-PL	1,432	N10SU	-	-	10.01.38.02867	-

Type (Suction cup)			Spare Parts		Part no.	
FXP	5R36	SPB2	-	Bellows suction cup (round)	SPB2 20	10.01.06.03125
FXP	5R36	SPB2	F	Bellows suction cup (round)	SPB2 20 F	10.01.38.00465
FXP	3R54	SPB2	-	Bellows suction cup (round)	SPB2 40	10.01.06.03126
FXP	3R54	SPB2	F	Bellows suction cup (round)	SPB2 40 F	10.01.38.00452

Area Gripping Systems FXP

Suction area (LxB) from 442 x 130 mm to 1,432 x 130 mm

Technical Data Area Gripping Systems FXP

Type (Sealing foam)*				Number of suction cells	Air consumption [l/min] [l/min]**	Suction rate max. [l/min]	Suction force (-600 mbar) [N]***	Weight [kg]
FXP-SW	442	3R18	O20	66	250	1,050	-	2.5
FXP-SW	640	3R18	O20	99	375	1,350	-	3.2
FXP-SW	838	3R18	O20	132	500	1,600	-	4.0
FXP-SW	1,234	3R18	O20	198	875	2,940	-	6.1
FXP-SW	1,432	3R18	O20	231	1,000	3,180	-	6.4
FXP-SW	442	3R18	O10010	66	250	1,050	-	2.5
FXP-SW	640	3R18	O10010	99	375	1,350	-	3.2
FXP-SW	838	3R18	O10010	132	500	1,600	-	3.8
FXP-SW	1,234	3R18	O10010	198	875	2,940	-	5.9
FXP-SW	1,432	3R18	O10010	231	1,000	3,180	-	6.6
FXP-SW	442	5R18	O10010	110	250	1,050	-	2.4
FXP-SW	640	5R18	O10010	165	375	1,350	-	3.1
FXP-SW	838	5R18	O10010	220	500	1,600	-	3.8
FXP-SW	1,234	5R18	O10010	330	875	2,940	-	5.9
FXP-SW	1,432	5R18	O10010	385	1,000	3,180	-	6.6
FXP-SW	442	5R18	N10SU	110	250	1,050	-	2.5
FXP-SW	640	5R18	N10SU	165	375	1,350	-	2.5
FXP-SW	838	5R18	N10SU	220	500	1,600	-	4.1
FXP-SW	1,234	5R18	N10SU	330	875	2,940	-	5.6
FXP-SW	1,432	5R18	N10SU	385	1,000	3,180	-	6.2
FXP-S-SW	442	3R18	O20	66	250	1,050	-	2.5
FXP-S-SW	640	3R18	O20	99	375	1,350	-	3.2
FXP-S-SW	838	3R18	O20	132	500	1,600	-	4.0
FXP-S-SW	1,234	3R18	O20	198	875	2,940	-	6.1
FXP-S-SW	1,432	3R18	O20	231	1,000	3,180	-	6.9
FXP-S-SW	442	5R18	O10010	110	250	1,050	-	2.5
FXP-S-SW	640	5R18	O10010	165	375	1,350	-	3.2
FXP-S-SW	838	5R18	O10010	220	500	1,600	-	3.9
FXP-S-SW	1,234	5R18	O10010	330	875	2,940	-	6.1
FXP-S-SW	1,432	5R18	O10010	385	1,000	3,180	-	6.8
FXP-i SW	442	3R18	O20	65	250	1,050	-	2.5
FXP-i SW	1,234	3R18	O20	197	875	2,940	-	6.1

*Sound level 74 dB(A)

**For compressed air with 5.5 bar input pressure

***At -0.25 bar and with the gripper fully covered by a workpiece typical for the application (cardboard bulging with structured surface)

Type (Sealing foam)*				Number of suction cells	Air consumption [l/min] [l/min]**	Suction rate max. [l/min]	Suction force (-600 mbar) [N]***	Weight [kg]
FXP-SVK	442	3R18	O20	66	250	1,050	-	2.2
FXP-SVK	640	3R18	O20	99	375	1,350	-	3.0
FXP-SVK	838	3R18	O20	132	500	1,600	-	3.8
FXP-SVK	1,234	3R18	O20	198	875	2,940	-	6.0
FXP-SVK	1,432	3R18	O20	231	1,000	3,180	-	6.8
FXP-SVK	442	3R18	O10010	66	250	1,050	-	2.2
FXP-SVK	640	3R18	O10010	99	375	1,350	-	3.0
FXP-SVK	838	3R18	O10010	132	500	1,600	-	3.8
FXP-SVK	1,234	3R18	O10010	198	875	2,940	-	6.0
FXP-SVK	1,432	3R18	O10010	231	1,000	3,180	-	6.8
FXP-SVK	442	5R18	O10010	110	250	1,050	-	2.2
FXP-SVK	640	5R18	O10010	165	375	1,350	-	3.0
FXP-SVK	838	5R18	O10010	220	500	1,600	-	3.8

Area Gripping Systems FXP

Suction area (LxB) from 442 x 130 mm to 1,432 x 130 mm

Type (Sealing foam)*				Number of suction cells	Air consumption [l/min] [l/min]**	Suction rate max. [l/min]	Suction force (-600 mbar) [N]***	Weight [kg]
FXP-SVK	1,234	5R18	O10010	330	875	2,940	-	6.0
FXP-SVK	1,432	5R18	O10010	385	1,000	3,180	-	6.8
FXP-SVK	442	5R18	N10SU	-	250	-	-	2.6
FXP-SVK	640	5R18	N10SU	-	375	-	-	3.4
FXP-SVK	838	5R18	N10SU	-	500	-	-	4.2
FXP-SVK	1,234	5R18	N10SU	-	875	-	-	5.7
FXP-SVK	1,432	5R18	N10SU	-	1,000	-	-	6.3
FXP-S-SVK	442	3R18	O20	66	250	1,050	-	2.8
FXP-S-SVK	640	3R18	O20	99	375	1,350	-	3.6
FXP-S-SVK	838	3R18	O20	132	500	1,600	-	4.4
FXP-S-SVK	1,234	3R18	O20	198	875	2,940	-	6.1
FXP-S-SVK	1,432	3R18	O20	231	1,000	3,180	-	6.7
FXP-S-SVK	442	5R18	O10010	110	250	1,050	-	2.8
FXP-S-SVK	640	5R18	O10010	165	375	1,350	-	3.6
FXP-S-SVK	838	5R18	O10010	220	500	1,600	-	4.4
FXP-S-SVK	1,234	5R18	O10010	330	875	2,940	-	6.1
FXP-S-SVK	1,432	5R18	O10010	385	1,000	3,180	-	6.7
FXP-i-SVK	442	3R18	O20	66	250	1,030	-	2.5
FXP-i-SVK	1,234	3R18	O20	198	875	2,940	-	6.3

*Sound level 74 dB(A)

**For compressed air with 5.5 bar input pressure

***At -0.25 bar and with the gripper fully covered by a workpiece typical for the application (cardboard bulging with structured surface)

Type (Suction cup)*				Number of suction cells	Air consumption [l/min] [l/min]**	Suction rate max. [l/min]	Suction force (-600 mbar) [N]***	Weight [kg]
FXP-SW	442	5R36	SPB2	55	250	1,050	-	2.9
FXP-SW	640	5R36	SPB2	82	375	1,350	-	3.9
FXP-SW	838	5R36	SPB2	110	500	1,600	-	4.8
FXP-SW	1,234	5R36	SPB2	165	875	2,940	-	7.5
FXP-SW	1,432	5R36	SPB2	193	1,000	3,180	-	8.4
FXP-SW	442	3R54	SPB2	23	250	1,050	-	3.1
FXP-SW	640	3R54	SPB2	33	375	1,350	-	4.1
FXP-SW	838	3R54	SPB2	44	500	1,600	-	5.2
FXP-SW	1,234	3R54	SPB2	66	875	2,940	-	8.0
FXP-SW	1,432	3R54	SPB2	77	1,000	3,180	-	9.0
FXP-S-SW	442	5R36	SPB2	55	250	1,050	-	2.9
FXP-S-SW	640	5R36	SPB2	82	375	1,350	-	3.9
FXP-S-SW	838	5R36	SPB2	110	500	1,600	-	4.8
FXP-S-SW	1,234	5R36	SPB2	165	875	2,940	-	7.5
FXP-S-SW	1,432	5R36	SPB2	193	1,000	3,180	-	8.4
FXP-S-SW	442	3R54	SPB2	23	250	1,050	-	3.1
FXP-S-SW	640	3R54	SPB2	33	375	1,350	-	4.1
FXP-S-SW	838	3R54	SPB2	44	500	1,600	-	5.2
FXP-S-SW	1,234	3R54	SPB2	66	875	2,940	-	8.0
FXP-S-SW	1,432	3R54	SPB2	77	1,000	3,180	-	9.0
FXP-i SW	442	3R54	SPB2	22	250	1,050	-	3.1
FXP-i SW	1,234	3R54	SPB2	66	875	2,940	-	8.0

*Sound level 74 dB(A)

**For compressed air with 5.5 bar input pressure

***At -0.25 bar and with the gripper fully covered by a workpiece typical for the application (cardboard bulging with structured surface)

Area Gripping Systems FXP

Suction area (LxB) from 442 x 130 mm to 1,432 x 130 mm

Type (Suction cup)*				Number of suction cells	Air consumption [l/min] [l/min]**	Suction rate max. [l/min]	Suction force (-600 mbar) [N]***	Weight [kg]
FXP-SVK	442	5R36	SPB2	55	250	1,050	-	2.7
FXP-SVK	640	5R36	SPB2	82	375	1,350	-	3.7
FXP-SVK	838	5R36	SPB2	110	500	1,600	-	4.5
FXP-SVK	1,234	5R36	SPB2	165	875	2,940	-	6.3
FXP-SVK	1,432	5R36	SPB2	193	1,000	3,180	-	8.3
FXP-SVK	442	3R54	SPB2	23	250	1,050	-	2.8
FXP-SVK	640	3R54	SPB2	33	375	1,350	-	3.8
FXP-SVK	838	3R54	SPB2	44	500	1,600	-	4.7
FXP-SVK	1,234	3R54	SPB2	66	875	2,940	-	6.5
FXP-SVK	1,432	3R54	SPB2	77	1,000	3,180	-	8.8
FXP-S-SVK	442	5R36	SPB2	55	250	1,050	-	3.6
FXP-S-SVK	640	5R36	SPB2	82	375	1,350	-	4.7
FXP-S-SVK	838	5R36	SPB2	110	500	1,600	-	5.7
FXP-S-SVK	1,234	5R36	SPB2	165	875	2,940	-	8.0
FXP-S-SVK	1,432	5R36	SPB2	193	1,000	3,180	-	8.9
FXP-S-SVK	442	3R54	SPB2	23	250	1,050	-	3.3
FXP-S-SVK	640	3R54	SPB2	33	375	1,350	-	4.4
FXP-S-SVK	838	3R54	SPB2	44	500	1,600	-	5.4
FXP-S-SVK	1,234	3R54	SPB2	66	875	2,940	-	7.7
FXP-S-SVK	1,432	3R54	SPB2	77	1,000	3,180	-	8.6
FXP-i-SVK	442	3R54	SPB2	23	250	1,030	-	3.1
FXP-i-SVK	1,234	3R54	SPB2	66	875	2,940	-	8.0

*Sound level 74 dB(A)

**For compressed air with 5.5 bar input pressure

***At -0.25 bar and with the gripper fully covered by a workpiece typical for the application (cardboard bulging with structured surface)

Area Gripping Systems FXP

Suction area (LxB) from 442 x 130 mm to 1,432 x 130 mm

Design Data Area Gripping Systems FXP

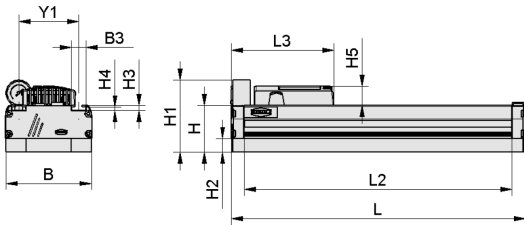

FXP O20, O10O10, N10SU

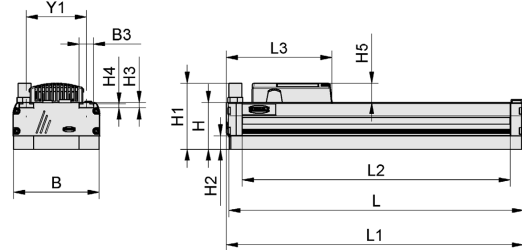

FXP-i 020

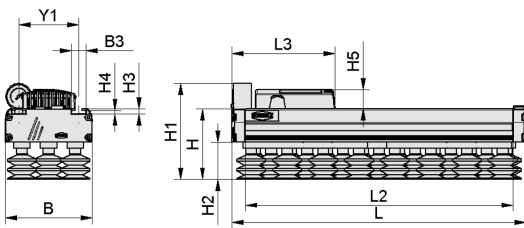

FXP SPB2

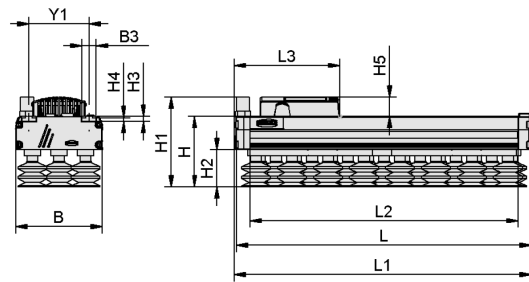

FXP-i SPB2

Area Gripping Systems FXP

Suction area (LxB) from 442 x 130 mm to 1,432 x 130 mm

Design Data Area Gripping Systems FXP

Type (Sealing foam)	B [mm]	B3 [mm]	H [mm]	H1 [mm]	H2 [mm]	H3 [mm]	H4 [mm]	H5 [mm]	L [mm]*	L2 [mm]	L3 [mm]	Y1 [mm]	
FXP	3R18	130	22	70	109	20	7.7	5.5	28	442	402	154	90
FXP	3R18	130	22	70	109	20	7.7	5.5	28	640	600	154	90
FXP	3R18	130	22	70	109	20	7.7	5.5	28	838	798	154	90
FXP	3R18	130	22	70	109	20	7.7	5.5	28	1,234	1,194	154	90
FXP	3R18	130	22	70	109	20	7.7	5.5	28	1,432	1,392	154	90
FXP	5R18	130	22	70	109	20	7.7	5.5	28	442	402	154	90
FXP	5R18	130	22	70	109	20	7.7	5.5	28	640	600	154	90
FXP	5R18	130	22	70	109	20	7.7	5.5	28	838	798	154	90
FXP	5R18	130	22	70	109	20	7.7	5.5	28	1,234	1,194	154	90
FXP	5R18	130	22	70	109	20	7.7	5.5	28	1,432	1,392	154	90
FXP-S	3R18	130	22	70	109	20	7.7	5.5	28	442	402	154	90
FXP-S	3R18	130	22	70	109	20	7.7	5.5	28	640	600	154	90
FXP-S	3R18	130	22	70	109	20	7.7	5.5	28	838	798	154	90
FXP-S	3R18	130	22	70	109	20	7.7	5.5	28	1,234	1,194	154	90
FXP-S	3R18	130	22	70	109	20	7.7	5.5	28	1,432	1,392	154	90
FXP-S	5R18	130	22	70	109	20	7.7	5.5	28	442	402	154	90
FXP-S	5R18	130	22	70	109	20	7.7	5.5	28	640	600	154	90
FXP-S	5R18	130	22	70	109	20	7.7	5.5	28	838	798	154	90
FXP-S	5R18	130	22	70	109	20	7.7	5.5	28	1,234	1,194	154	90
FXP-S	5R18	130	22	70	109	20	7.7	5.5	28	1,432	1,392	154	90
FXP-i	3R18	130	22	70	99	20	7.7	5.5	29	442	402	159	90
FXP-i	3R18	130	22	70	99	20	7.7	5.5	29	1,234	1,194	159	90

*Two ejectors/silencer box covers are used for the 1,234 mm and 1,432 mm length. Type FXP requires compressed air hose 12/9 mm.

Type (Suction cup)	B [mm]	B3 [mm]	H [mm]	H1 [mm]	H2 [mm]	H3 [mm]	H4 [mm]	H5 [mm]	L [mm]*	L2 [mm]	L3 [mm]	Y1 [mm]		
FXP	5R36	SPB2	130	22	83	122	33	7.7	5.5	28	442	402	154	90
FXP	5R36	SPB2	130	22	83	122	33	7.7	5.5	28	640	600	154	90
FXP	5R36	SPB2	130	22	83	122	33	7.7	5.5	28	838	798	154	90
FXP	5R36	SPB2	130	22	83	122	33	7.7	5.5	28	1,234	1,194	154	90
FXP	5R36	SPB2	130	22	83	122	33	7.7	5.5	28	1,432	1,392	154	90
FXP	3R54	SPB2	130	22	105	144	55	7.7	5.5	28	442	402	154	90
FXP	3R54	SPB2	130	22	105	144	55	7.7	5.5	28	640	600	154	90
FXP	3R54	SPB2	130	22	105	144	55	7.7	5.5	28	838	798	154	90
FXP	3R54	SPB2	130	22	105	144	55	7.7	5.5	28	1,234	1,194	154	90
FXP	3R54	SPB2	130	22	105	144	55	7.7	5.5	28	1,432	1,392	154	90
FXP-i	3R54	SPB2	130	22	106	134	56	7.7	5.5	29	442	402	159	90
FXP-i	3R54	SPB2	130	22	106	134	56	7.7	5.5	29	1,234	1,194	159	90

*Two ejectors/silencer box covers are used for the 1,234 mm and 1,432 mm length. Type FXP requires compressed air hose 12/9 mm.

Multimedia product presentation

Medium	Link
Product video	https://vimeo.com/147433631 https://vimeo.com/316498901 https://vimeo.com/322728286