

Claw Pumps EVE-KL

Suction rate from 90 m³/h to 310 m³/h

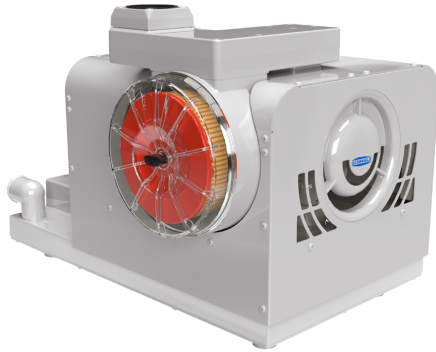

Suitability for Industry Specific Applications



Claw Pumps EVE-KL

Applications

- Energy efficient and low-maintenance vacuum pump for handling large-area components such as wooden boards
- Use in processing machines as central vacuum supply with long maintenance intervals
- Dry and oil-free vacuum generation for environments with high demands on cleanliness and low emissions
- High suction rate for workpieces with rough surfaces such as rough sawn wood or scaled sheet metal

Design

- Connection with G2 1/2" female thread for suction air (1)
- Integrated filter with transparent cover (2)
- Air outlet with integrated silencer (3)
- Motor (4) in different voltage versions
- Ring eyes (5) for securely balanced transport

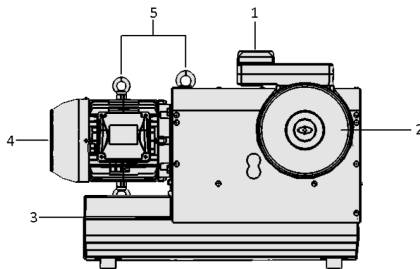

System Design Claw Pumps EVE-KL

Product Highlights

- Dry-running vacuum pump with high suction rate and high vacuum for large-area suction of dense and slightly porous workpieces
- Ideally suited as central vacuum generation in machines and plants thanks to high efficiency and compact design
- Nearly wear-free, contactless operating principle enables very long maintenance intervals
- Integrated, large-volume and easily accessible suction air filter saves additional filters

Designation Code Claw Pumps EVE-KL

Claw Pumps EVE-KL

Suction rate from 90 m³/h to 310 m³/h



1 – Abbreviated designation

Code	Version
EVE	EVE

2 – Pump type

Code	Type
KL	Claw Pumps EVE-KL

3 – Performance class

Code	Suction rate in m ³ /h
100...300	100 to 300

4 – Supply voltage

Code	Type
AC3	Three phase

5 – Motor type

Code	Region
FU	Frequency converter control
IE3-TYP1	EU/CN/IND
IE3-TYP2	US/CAN
IE3-TYP3	JPN/KOR/BRA
IE3-TYP4	CAN

6 – Product addition

Code	Type
F	Additional filter

The claw pump EVE-KL, available in three sizes for all common supply voltages, is supplied as a ready-to-connect product.

Available spare parts: Replacement filters in paper and polyester

Ordering Data Claw Pumps EVE-KL

Type	Part no.
EVE-KL 100 AC3 IE3-TYP1 F	10.03.01.00683
EVE-KL 100 AC3 IE3-TYP2 F	10.03.01.00684
EVE-KL 100 AC3 IE3-TYP3 F	10.03.01.00685
EVE-KL 100 AC3 IE3-TYP4 F	10.03.01.00686
EVE-KL 100 AC3 FU	10.03.01.00843
EVE-KL 150 AC3 IE3-TYP1 F	10.03.01.00687
EVE-KL 150 AC3 IE3-TYP2 F	10.03.01.00688
EVE-KL 150 AC3 IE3-TYP3 F	10.03.01.00689
EVE-KL 150 AC3 IE3-TYP4 F	10.03.01.00690
EVE-KL 150 AC3 FU	10.03.01.00833
EVE-KL 300 AC3 IE3-TYP1 F	10.03.01.00691
EVE-KL 300 AC3 IE3-TYP2 F	10.03.01.00692
EVE-KL 300 AC3 IE3-TYP3 F	10.03.01.00693
EVE-KL 300 AC3 IE3-TYP4 F	10.03.01.00694
EVE-KL 300 AC3 FU	10.03.01.00834

Ordering Data Spare Parts Claw Pumps EVE-KL

Spare Parts	Part no.
FILT-EINS 197x102 PAP EVE-KL	Filter insert (round), material paper 10.03.01.00701
FILT-EINS 197x102 PES EVE-KL	Filter insert (round), material polyester 10.03.01.00702
OEL EVE-KL 1L	Oil 27.02.01.00078

Claw Pumps EVE-KL

Suction rate from 90 m³/h to 310 m³/h

Technical Data Claw Pumps EVE-KL

Type	Voltage at 50 Hz	Voltage at 60 Hz	Suction rate (50 Hz) [m ³ /h]	Suction rate (60 Hz) [m ³ /h]	Rated power 50 Hz [kW]	Rated power 60 Hz [kW]	Protection type IP	Weight [kg]
EVE-KL 100 AC3 FU	400-480V AC3	400-480V AC3	-	120	4.00	4.00	IP 55	178
EVE-KL 100 AC3 IE3-TYP1 F	-	460V - 3-phase AC	100	120	2.21	2.21	IP 55	121
EVE-KL 100 AC3 IE3-TYP2 F	D230V/Y400V ±10%	YY230V/Y460V ±10%	100	120	3.00	3.00	IP 55	133
EVE-KL 100 AC3 IE3-TYP3 F	D200V/Y350V ±10 %	-	100	120	2.21	2.64	IP 55	131
EVE-KL 100 AC3 IE3-TYP4 F	D290V/Y500V ±10%	D330V/Y575V ±10%	100	120	3.00	3.00	IP 55	125
EVE-KL 150 AC3 FU	400-480V AC3	400-480V AC3	-	180	-	3.00	IP 55	208
EVE-KL 150 AC3 IE3-TYP1 F	-	460V - 3-phase AC	150	180	3.00	3.00	IP 55	190
EVE-KL 150 AC3 IE3-TYP2 F	D230V/Y400V ±10%	-	150	180	4.00	4.00	IP 55	201
EVE-KL 150 AC3 IE3-TYP3 F	D200V/Y350V ±10 %	-	150	180	3.00	3.60	IP 55	200
EVE-KL 150 AC3 IE3-TYP4 F	D290V/Y500V ±10%	D330V/Y575V ±10%	150	180	4.00	4.00	IP 55	194
EVE-KL 300 AC3 FU	400-480V AC3	400-480V AC3	-	325	-	-	IP 55	340
EVE-KL 300 AC3 IE3-TYP1 F	-	-	275	325	5.50	6.60	IP 55	323
EVE-KL 300 AC3 IE3-TYP2 F	D230V/Y400V ±10%	-	275	325	7.50	7.50	IP 55	328
EVE-KL 300 AC3 IE3-TYP3 F	D200V/Y350V ±10 %	-	275	325	5.50	6.60	IP 55	331
EVE-KL 300 AC3 IE3-TYP4 F	D290V/Y500V ±10%	D330V/Y575V ±10%	275	325	7.50	7.50	IP 55	329

Claw Pumps EVE-KL

Suction rate from 90 m³/h to 310 m³/h

Design Data Claw Pumps EVE-KL

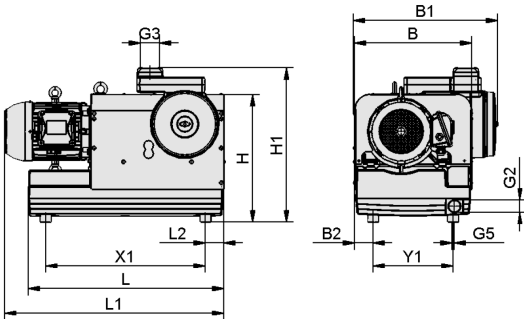

EVE-KL

Claw Pumps EVE-KL

Suction rate from 90 m³/h to 310 m³/h

Design Data Claw Pumps EVE-KL

Type	B [mm]	B1 [mm]	B2 [mm]	G2	G3	G5	H [mm]	H1 [mm]	L [mm]	L1 [mm]	L2 [mm]	X1 [mm]	Y1 [mm]
EVE-KL 100 AC3 IE3- TYP1 F	440	537	70	G1-1/2"-F	G2-1/2"-F	M10-F	431	533	735	768	70	600	300
EVE-KL 100 AC3 IE3- TYP2 F	440	537	70	G1-1/2"-F	G2-1/2"-F	M10-F	431	533	735	805	70	600	300
EVE-KL 100 AC3 IE3- TYP3 F	440	537	70	G1-1/2"-F	G2-1/2"-F	M10-F	431	533	735	805	70	600	300
EVE-KL 100 AC3 IE3- TYP4 F	440	537	70	G1-1/2"-F	G2-1/2"-F	M10-F	431	533	735	799	70	600	300
EVE-KL 100 AC3 FU	440	537	70	G1-1/2"-F	G2-1/2"-F	M10-F	431	533	735	847	70	600	300
EVE-KL 150 AC3 IE3- TYP1 F	440	537	70	G1-1/2"-F	G2-1/2"-F	M10-F	478	580	735	805	70	600	300
EVE-KL 150 AC3 IE3- TYP2 F	440	537	70	G1-1/2"-F	G2-1/2"-F	M10-F	478	580	735	823	70	600	300
EVE-KL 150 AC3 IE3- TYP3 F	440	537	70	G1-1/2"-F	G2-1/2"-F	M10-F	478	580	735	847	70	600	300
EVE-KL 150 AC3 IE3- TYP4 F	440	537	70	G1-1/2"-F	G2-1/2"-F	M10-F	478	580	735	823	70	600	300
EVE-KL 150 AC3 FU	440	537	70	G1-1/2"-F	G2-1/2"-F	M10-F	478	580	735	833	70	600	300
EVE-KL 300 AC3 IE3- TYP1 F	483	580	92	G2"-F	G2-1/2"-F	M10-F	541	624	808	918	71	670	300
EVE-KL 300 AC3 IE3- TYP2 F	483	580	92	G2"-F	G2-1/2"-F	M10-F	541	624	808	918	71	670	300
EVE-KL 300 AC3 IE3- TYP3 F	483	580	92	G2"-F	G2-1/2"-F	M10-F	541	624	808	918	71	670	300
EVE-KL 300 AC3 IE3- TYP4 F	483	580	92	G2"-F	G2-1/2"-F	M10-F	541	624	808	918	71	670	300
EVE-KL 300 AC3 FU	483	580	92	G2"-F	G2-1/2"-F	M10-F	541	624	808	956	71	670	300