

# ELECTRIC CYLINDER SERIES ELEKTRO ISO 15552 EK

An electric cylinder with a connection interface in accordance with ISO 15552.

The ELEKTRO ISO 15552 EK series stands out for some design choices that made it possible to reduce the length and cut costs, with a few different technical characteristics.

The piston rod moves forward by means of either a hardened and tempered screw and a ball recirculating screw nut or a trapezoidal screw (acme) and bronze bushing.

The cylinder comes with a built-in anti-rotation system obtained with two technopolymer pads that slide in the liner along two longitudinal grooves.

The piston has a magnet and the liner has slots that accommodate magnetic sensors.

A greasing system is incorporated to lubricate the screw/ball screw nut.

Only a version with inline motor, which is shorter than the equivalent ELEKTRO ISO15552 cylinder, is provided. The version with geared motors is available on specific request.

A steel bracket to be fixed to the rear head, with an interface suitable for ISO 15552 cylinder accessories, is provided to be fixed to the cylinder from the rear side.

The cylinder can be supplied with a STEPPING or a BRUSHLESS motor, with or without parking brake.

Cylinders with a flange suitable for a motor brand that is most liked by the customer are available on request.

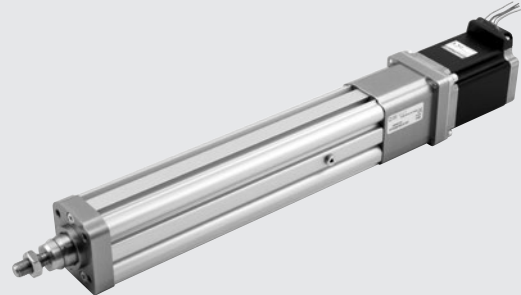

## TECHNICAL DATA

		Ø 32
Piston rod thread	mm	M10x1.25
Environmental temperature range for STEPPING motors	°C	from -10 to +50
BRUSHLESS motors	°C	from 0 to +40
Electrical protection rating with motors		IP40
Minimum stroke		Twice the screw pitch (to guarantee ball lubrication)
Maximum stroke	mm	500
Positioning repeatability	mm	± 0.02 with screw/ball screw nut; ± 0.15 with trapezoidal screw (acme)
Positioning accuracy	mm	± 0.2 **
Overall radial oscillation of the piston rod (without load) for 100 mm of stroke	mm	0.4
Versions		Ball screw; trapezoidal screw (acme) with bronze bushing
Anti-rotation of the piston rod		YES
Maximum angle of twist of the piston rod		1°30'
Motor layout		In line with piston rod axis
Uncontrolled impact at the end of stroke		NOT ALLOWED (it provides an extra-stroke minimum 5 mm)
Sensor magnet		YES
Work position		Any

\*\* indicative average data that gets influenced by various factors such as the stroke, the type of motor, the cylinder version, etc ...

MECHANICAL FEATURES		Ball screw		Trapezoidal screw (acme) with bronze bushing
Screw pitch (p)	mm	4	10	4
Screw diameter	mm	12	12	14
Static axial load (F <sub>o</sub> )*	N	3000	3000	3000
Dynamic axial load (F)	N	5200	3160	see graph force/speed
		Calculate mean axial load and the calculate life (see graphs on page A5.43)		<b>N.B.:</b> 40% duty cycle, i.e. the cylinder must work maximum 40% of time to allow the screw/ball screw nut to cool down.
Maximum number of revs	1/min	3000	3000	750
Maximum speed (V <sub>max</sub> )	mm/s	200	500	50
"K" ratio of motor revs and piston rod speed	n/V	15	6	15

Example: V = 100 mm/s; pitch = 10 → K=6 n= V x K = 100 x 6 = 600 rpm

\* **N.B.:** Static loads bearable without damage. Payloads are shown in the diagrams on page A5.44 onwards.

WEIGHTS (ONLY CYLINDER)		Ball screw		Trapezoidal screw (acme) with bronze bushing
Screw pitch (p)	mm	4	10	4
Weight at stroke 0, without motor	g	610	620	720
Additional weight each mm of stroke	g	4.3	4.3	4.3
Moving mass at stroke 0 (Mx)	g	189.4	189.4	209.4
Additional moving mass each mm of stroke	g	1.3	1.3	1.3

**N.B.:** You get the total weight of a complete cylinder by adding: weight stroke 0 + stroke [mm] x weight for each mm of stroke + weight of the motor.

MASS MOMENTS OF INERTIA		Ball screw		Trapezoidal screw (acme) with bronze bushing
Screw pitch	mm	4	10	4
J0 at stroke 0	kgmm <sup>2</sup>	9.9849	10.0979	10.2979
J1 each metre of stroke	kgmm <sup>2</sup> /m	12.76	13.76	16.81
J2 each kg of load	kgmm <sup>2</sup> /kg	0.4053	2.533	0.4053

The total mass moment of inertia (Jtot) reduced for the motor is: Jtot = J0 + J1 · stroke [m] + J2 · (load [kg] + Mx [kg])

Mx is defined in the weights table.

### CALCULATION OF MEAN AXIAL LOAD F<sub>m</sub> AND VERIFICATION

Peak axial load in a work cycle must not exceed the static axial load F<sub>o</sub>.

The peak value is usually achieved during upward acceleration in vertical installation. Exceeding this value leads to greater wear and hence shorter life of the recirculating ball screw.

Mean axial load F<sub>m</sub>

$$F_m = \sqrt[3]{\sum F_x^3 \times \frac{V_x}{V_m} \times \frac{q}{100}} =$$

$$F_m = \sqrt[3]{F_{x1}^3 \times \frac{V_{x1}}{V_m} \times \frac{q_1}{100} + F_{x2}^3 \times \frac{V_{x2}}{V_m} \times \frac{q_2}{100} + F_{x3}^3 \times \frac{V_{x3}}{V_m} \times \frac{q_3}{100} + \dots}$$

- F<sub>x</sub> = Axial load at stage x
- F<sub>m</sub> = Mean axial load during extension
- F<sub>o</sub> = Static axial load
- q = Time segment
- V<sub>x</sub> = Speed in the phase x
- V<sub>m</sub> = Average speed

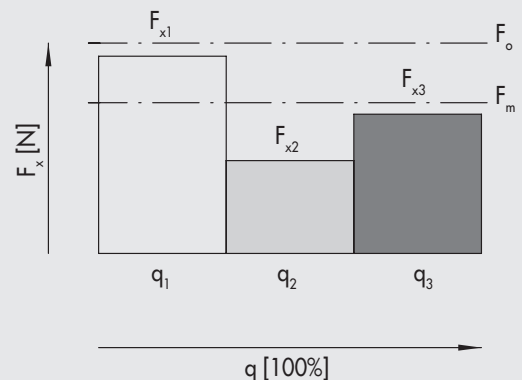

The mean axial load must not exceed the dynamic axial load: F<sub>m</sub> ≤ F

The graphs on page A5.44 show screw life as a function of F<sub>m</sub>

COMPONENTS

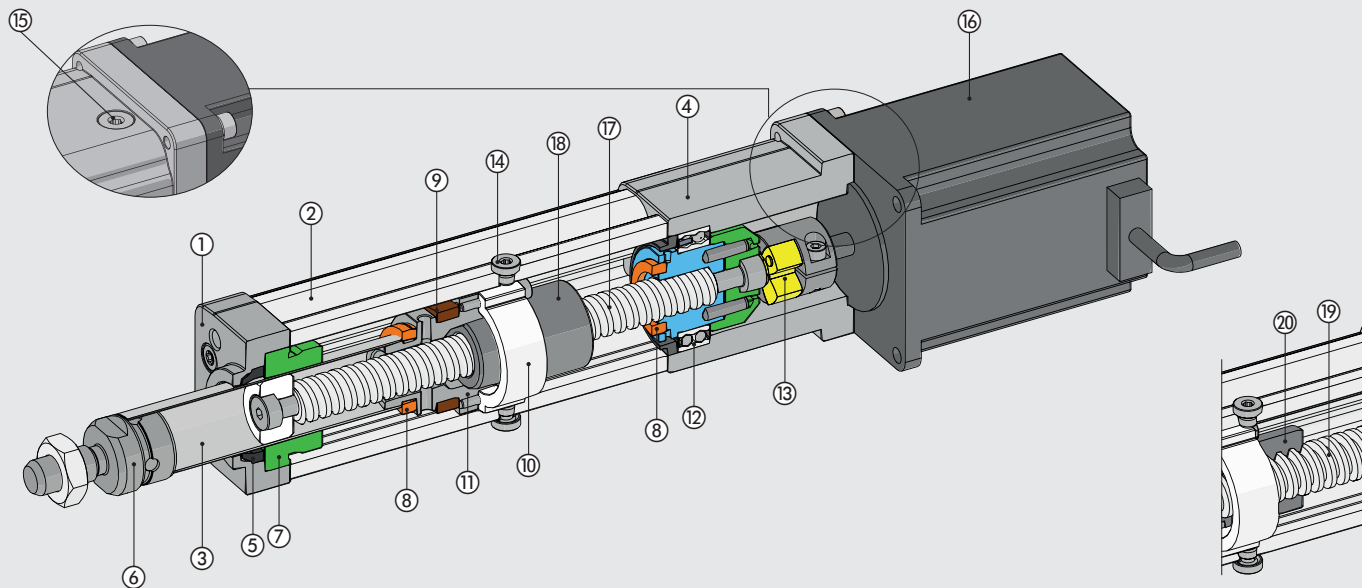

- ① FRONT CYLINDER HEAD: anodized aluminium
- ② BARREL: extruded and anodized aluminium alloy
- ③ PISTON ROD: stainless steel pipe
- ④ REAR CYLINDER HEAD: anodized aluminium
- ⑤ WIPER RING: polyurethane
- ⑥ NIPPLE: stainless steel
- ⑦ GUIDE BUSHING: technopolymer
- ⑧ BUFFER: polyurethane
- ⑨ MAGNET: plastroferrite
- ⑩ GUIDE AND ANTI-ROTATION RING: technopolymer
- ⑪ PISTON: aluminium
- ⑫ BEARING: oblique with two ball rings

- ⑬ ELASTIC COUPLING: aluminium / polyurethane
- ⑭ PLUG: remove it to insert the greaser
- ⑮ PLUG: for access to the elastic coupling screw
- ⑯ ELECTRIC MOTOR

**Version with ball screw:**

- ⑰ SCREW: hardened and rolled steel
- ⑱ NUT: ball recirculating

**Version with trapezoidal screw (acme):**

- ⑲ TRAPEZOIDAL SCREW (ACME): steel
- ⑳ NUT: bronze

FIXING OPTIONS

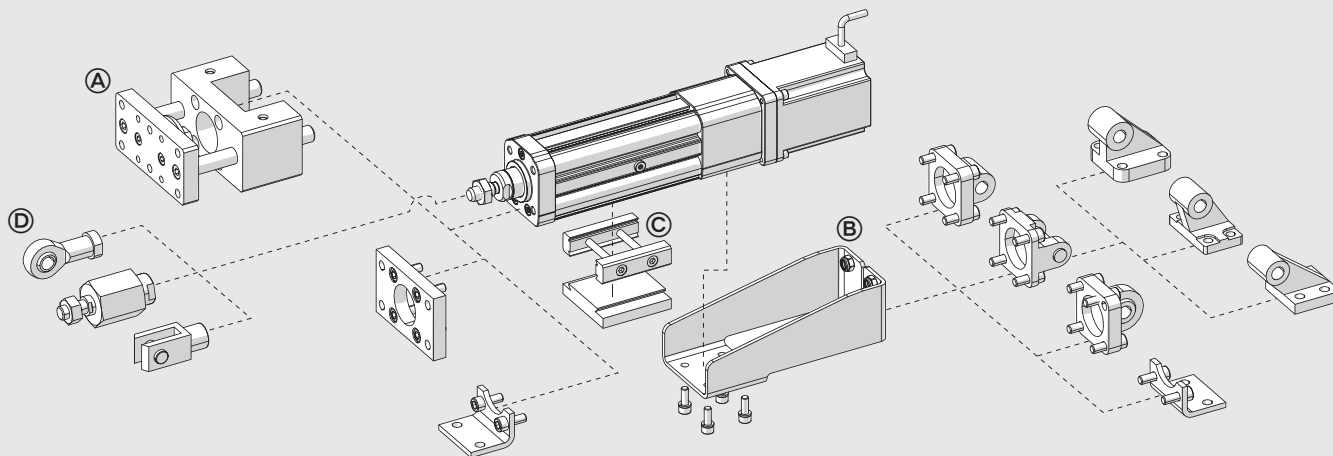

- Ⓐ Fixing on the front head with 4 threaded holes according to ISO 15552 standard.
- Ⓑ Fixing on the rear side, using the "rear fixing bracket". ISO 15552 accessories can be fitted onto this bracket.
- Ⓒ Fixing on one side of the liner, using QS fixing elements. See page A3.15
- Ⓓ Piston rod accessories.

**PEAK LOADS**

With vertical installations, the following load conditions applied to the piston rod must be met.

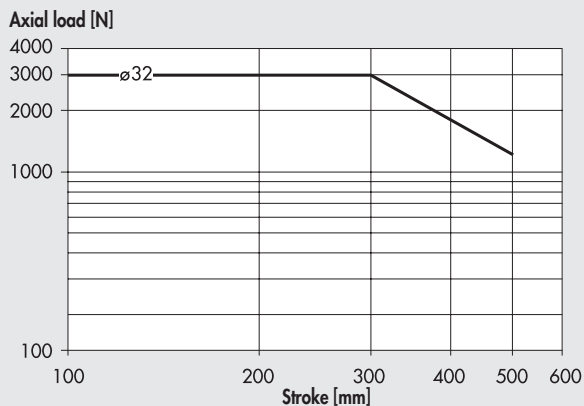

**MAXIMUM RADIAL LOADS ON PISTON ROD**

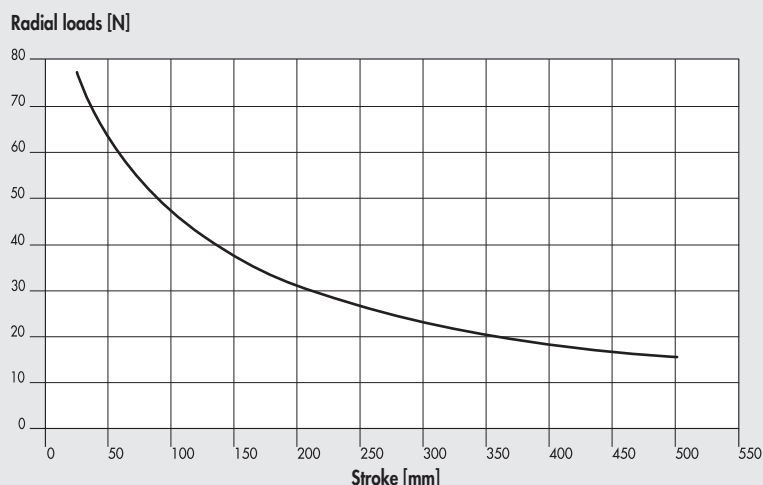

Radial loads can be applied to the piston rod. They must not exceed the values in the adjacent chart, otherwise the guides on the rod and piston will be subjected to excessive wear.

**LIFE CHARACTERISTICS AS A FUNCTION OF THE MEAN AXIAL LOAD, BALL SCREW VERSION**

Life characteristics can vary considerably from those indicated in the graphs due to different operating conditions (radial loads, temperature, lubrication status, etc.).

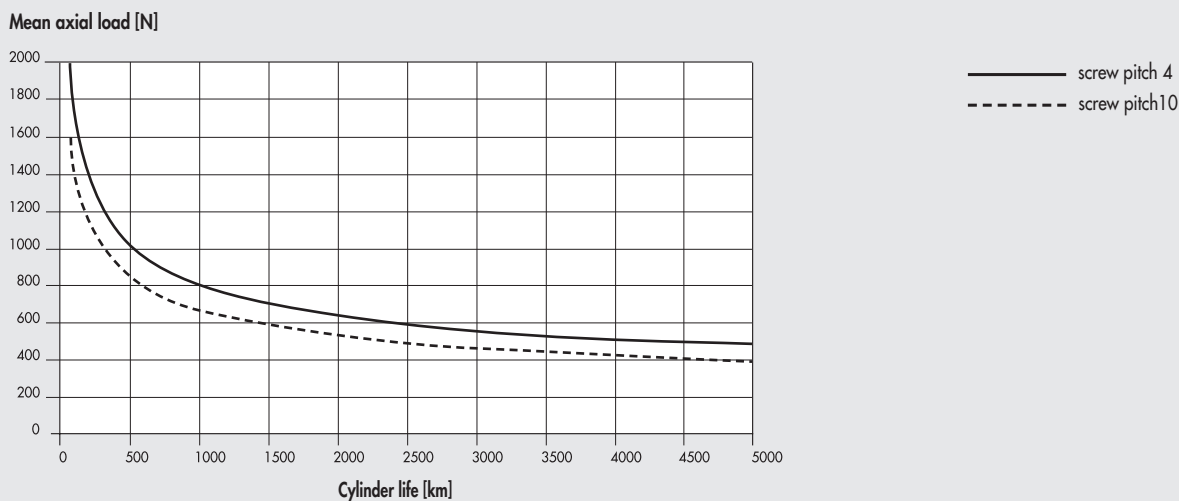

MAX. FORCE/SPEED CHART FOR VERSION WITH TRAPEZOIDAL SCREW (ACME) WITH BRONZE BUSHING

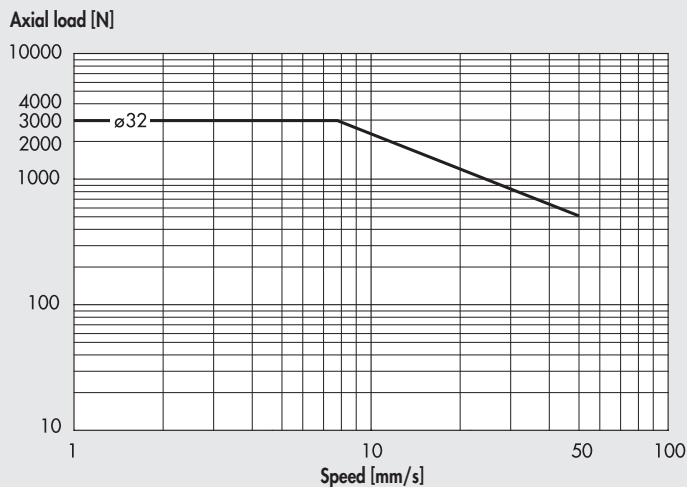

To prevent the bushing from excessive wear and tear, it is recommended to work below the curve indicated.

AXIAL LOAD CURVES AS A FUNCTION OF SPEED (CYLINDER COMPLETE WITH MOTOR AND DRIVE)

N.B.: The obtainable load values already take the efficiency of the system into account. For STEPPING motors, with the motor off, the drive current is automatically reduced by 50% to prevent overheating. Consequently, available axial load with the motor stopped is also reduced by 50%.

Ø 32 with pitch 4 ball screw, STEPPING motor and STEPPING motor with brake

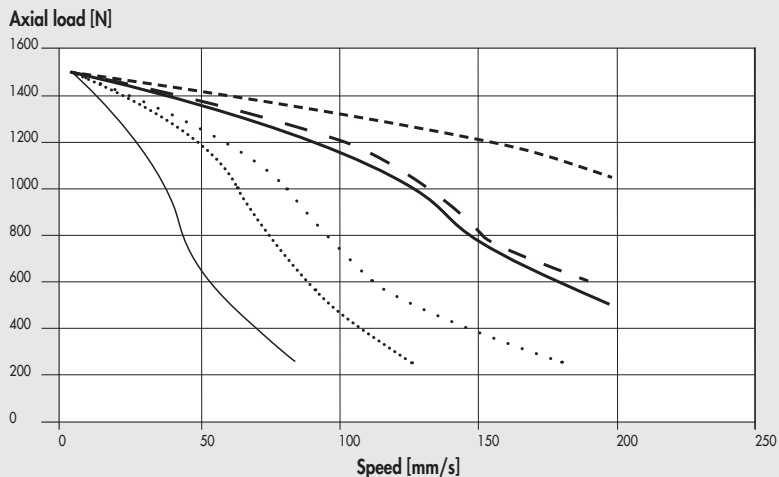

- 37M5120000 (with brake, 24VDC)
- ..... 37M5120000 (with brake, 48VDC)
- 37M5120000 (with brake, 75VDC)
- ..... 37M1120001 (24VDC)
- 37M1120001 (48VDC)
- 37M1120001 (75VDC)

Ø 32 with pitch 10 ball screw, STEPPING motor and STEPPING motor with brake

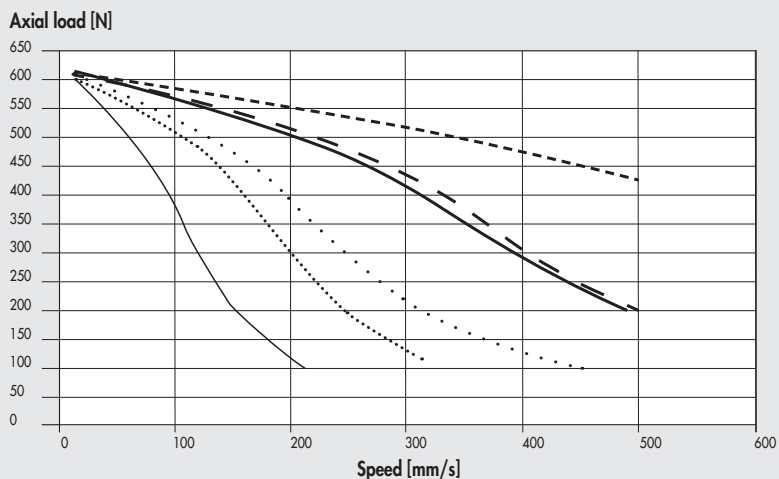

- 37M5120000 (with brake, 24VDC)
- ..... 37M5120000 with brake, 48VDC)
- 37M5120000 (with brake, 75VDC)
- ..... 37M1120001 (24VDC)
- 37M1120001 (48VDC)
- 37M1120001 (75VDC)

**Ø 32 with pitch 4 ball screw, BRUSHLESS motor and BRUSHLESS motor with brake**

Axial load [N]

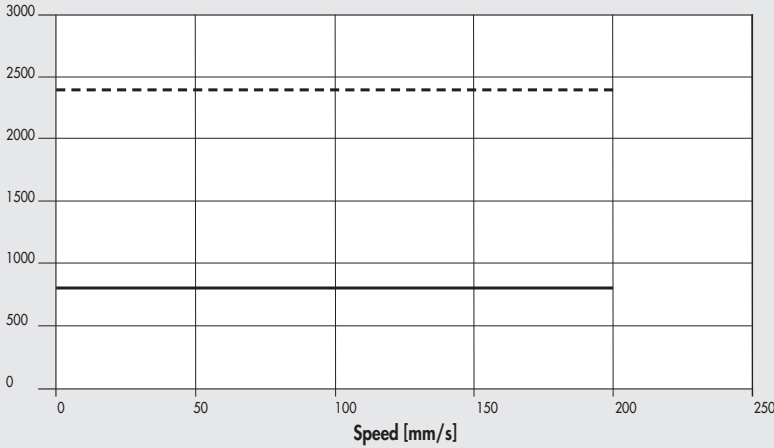

- Nominal 37M2200001 or 37M4200001 (with brake) + 37D2200001 (200W)
- - - Maximum 37M2200001 or 37M4200001 (with brake) + 37D2200001 (200W)

**Ø 32 with pitch 10 ball screw, BRUSHLESS motor and BRUSHLESS motor with brake**

Axial load [N]

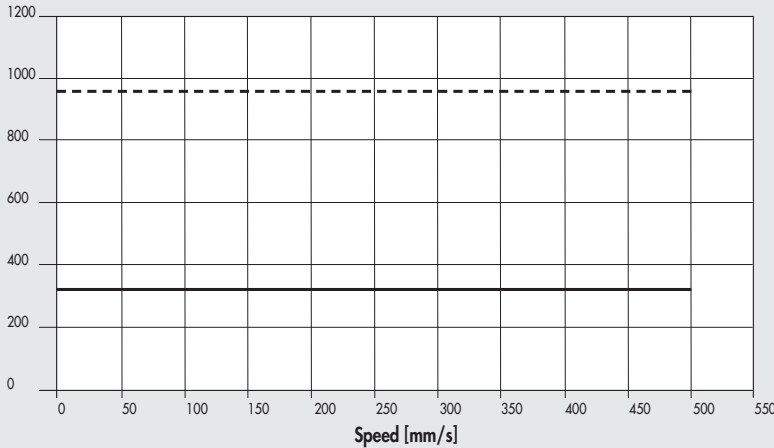

- Nominal 37M2200001 or 37M4200001 (with brake) + 37D2200001 (200W)
- - - Maximum 37M2200001 or 37M4200001 (with brake) + 37D2200001 (200W)

**Ø 32 with pitch 4 trapezoidal screw (acme), STEPPING motor**

Axial load [N]

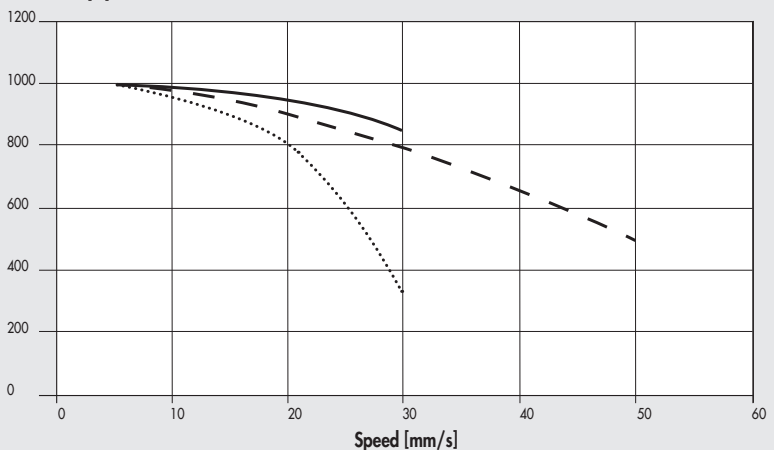

- ..... 37M1230000 (24VDC)
- - - 37M1230000 (48VDC)
- 37M1230000 (75VDC)

Ø 32 with pitch 4 trapezoidal screw (acme), BRUSHLESS motor

Axial load [N]

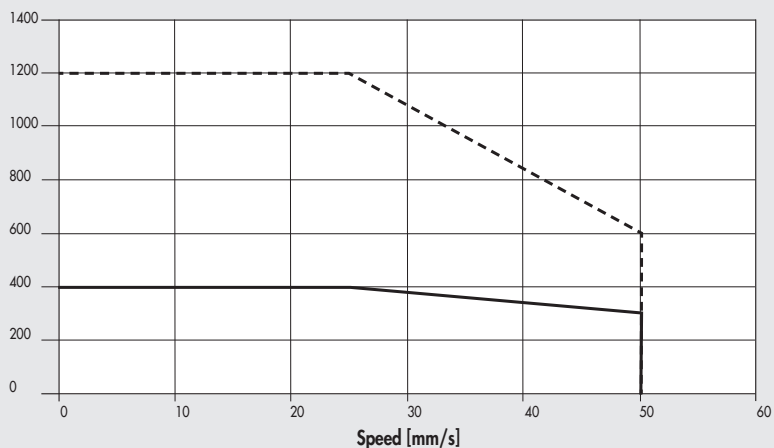

— Nominal 37M2200001 + 37D2200001 (200W)  
 - - - Maximum 37M2200001 + 37D2200001 (200W)

LUBRICATION DIAGRAMS

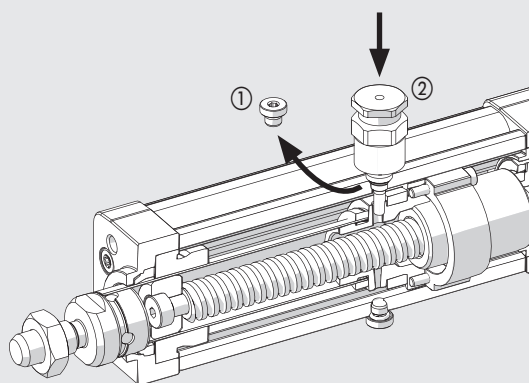

- Retract the piston rod towards the rear head. The piston rod/piston/ball screw system must rest against the buffer of the rear head.
- Unscrew the cap ① on the lubricator port.
- Screw the lubricating pin ② (code 0950327108) into the thread. Make sure you enter the corresponding hole in the piston below.
- Pump grease (code 9910506) using the suitable lubricator according to the quantity in table.
- Unscrew the lubricating pin and make the piston rod perform four complete strokes. The piston rod should end up in the initial (retracted) position.
- Repeat the last two operations.
- The operation of re-greasing will have to be repeated at least once a year.

		Ø 32	
Screw pitch (p)	mm	4	10
Relube grease quantity	g	0.3	0.5
	cc	0.26	0.42

**N.B.:** These are indicative values that can change as a function of the stroke

NOTES

**DIMENSIONS**

**WITHOUT MOTOR**

- + = Add the stroke
- ① = Slots for sensors
- ② = Slots for anti-rotation
- ③ = Dovetail for QS fixing
- ④ = Threaded holes for fixing brackets with ISO 15552 accessories
- ⑤ = Lubricator port

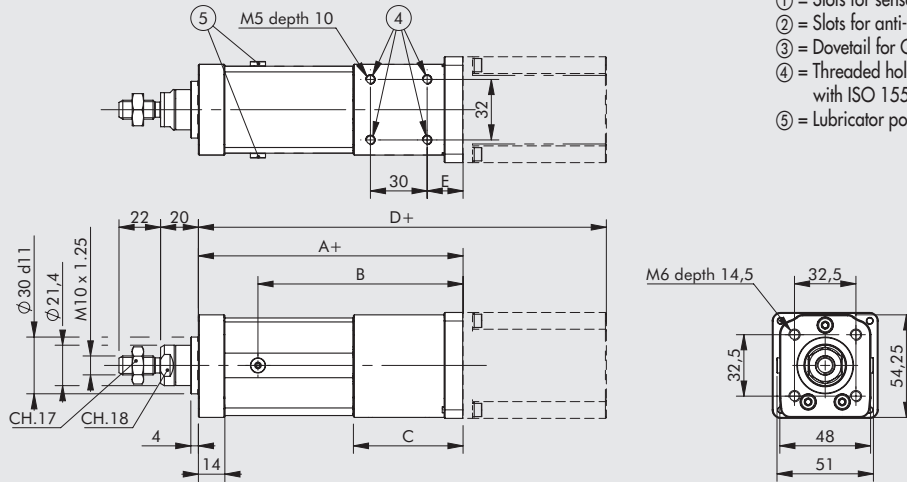
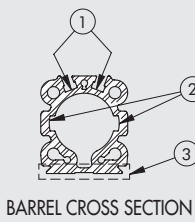

**WITH MOTOR**

**Overall dimensions for standard drive**

STEPPING MOTOR code 37M1120001					STEPPING MOTOR code 37M1230000					BRUSHLESS MOTOR code 37M2200001					STEPPING MOTORE WITH BRAKE WITHOUT ENCODER code 37M5120000					BRUSHLESS MOTOR WITH BRAKE code 37M4200001				
A	B	C	D	E	A	B	C	D	E	A	B	C	D	E	A	B	C	D	E	A	B	C	D	E
140	108.5	58	215.8	19	141	109.5	59	226.8	20	150.5	119	68.5	256	20	140	108.5	58	251.8	19	150.5	119	68.5	292.1	20

**NOTES**



## MOTOR-DRIVE COUPLINGS



MOTOR CODES		DRIVES CODES		
Metal Work	Manufacturer			
		<b>37D1222000 *</b>	<b>37D1332000 *</b>	<b>37D1552000</b>
		<b>RTA CSD 94</b>	<b>RTA NDC 96</b>	<b>RTA PLUS B7</b>
		<b>(4.4A 24-48VDC)</b>	<b>(6A 24-75VDC)</b>	<b>(10A 28-62VAC) ●</b>
<b>STEPPING MOTORS</b>				
<b>37M1120001</b>	<b>SANYO DENKI 103-H7126-6640 (5.6A 75V max)</b>	-	√	√ ■
<b>37M1230000 ▲</b>	<b>SANYO DENKI 103-H7823-1740 (4A 75V max)</b>	√	√ ◆	√ ■
<b>STEPPING MOTORS WITH BRAKE</b>				
<b>37M5120000</b>	<b>SANYO DENKI 103-H7126-1710B (4A 75V max)</b>	√	√ ◆	√ ■

\* In all applications requiring motor powered up to 6A / 55VDC, the programmable drive e.drive, code 37D1332002, can be used.  
 ◆ Important! Limit current  
 ■ Important! Limit current and voltage  
 ● Important! AC drive to continuous voltage VDC = VAC · √2  
 ▲ Used for trapezoidal screws only

MOTOR CODES		DRIVES CODES
Metal Work	Manufacturer	
		<b>37D2200001</b>
		<b>DELTA ASD-A2-0221-M</b>
		<b>(200W)</b>
<b>BRUSHLESS MOTORS</b>		
<b>37M2200001</b>	<b>DELTA ECMA-C20602RS (200W)</b>	√
<b>BRUSHLESS MOTORS WITH BRAKE</b>		
<b>37M4200001</b>	<b>DELTA ECMA-C20602SS (200W)</b>	√

### KEY TO CODES

CYL								DRIVE			
	37 TYPE	1 FAMILY	E SERIES	32 SIZE	0500 STROKE	1 SCREW PITCH	2 VERSION	1 MOTOR	1 FLANGE	2 TORQUE	1
	37 Electric actuators	1 ISO 15552 electric cylinder	E Elektro EK	32 Ø32		1 With pitch 4 ball screw 4 With pitch 10 ball screw T With pitch 4 trapezoidal screw (acme)	2 With non-rotating, IP40	1 STEPPING 2 BRUSHLESS 4 BRUSHLESS with BRAKE 5 STEPPING WITH BRAKE (without encoder)	1 NEMA 23 2 60x60	0 0 - 0.79 Nm 2 1.2 - 2.19 Nm 3 2.2 - 3 Nm	0 Base 1 Greater rpm

### POSSIBLE ORDERING CODES

#### Ø 32 with ball screw

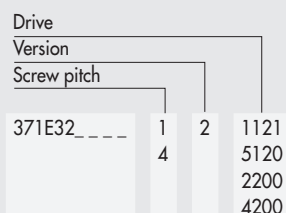

\_\_\_\_ = Enter the stroke in mm

#### Ø 32 with trapezoidal screw (acme)

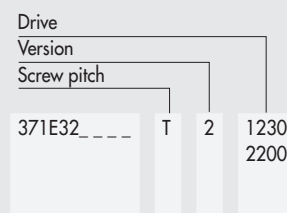

\_\_\_\_ = Enter the stroke in mm

### NOTE

## ACCESSORIES FOR ELECTRIC CYLINDER SERIES ELEKTRO ISO 15552 EK

Note: Where specified, limit the maximum axial loads ( $F_{max}$ ) according to the electric cylinders

### FIXING ELEMENTS QS

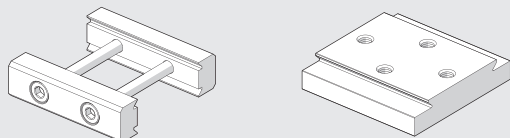

See V-Lock family.

### BRACKET FOR REAR FIXING

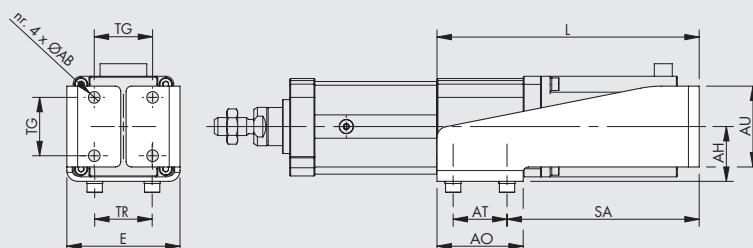

#### STEEL

Code	Ø	ØAB	TG	TR	E	AT	SA	AO	AU	AH	L	Weight [g]	$F_{max}$ [N]
0950327090	32	6.5	32.5	32	63	30	107	48	45	30.5	146	375	1600
0950327091	32	6.5	32.5	32	67	30	144.5	48	45	30.5	183.5	445	1600

Note: Supplied complete with 4 screws and 4 washers for fixing to the cylinder, 4 self-locking nuts and 4 screws for fixing the anchor clamp.

N.B.: Code 0950327090 can be used with motor 37M1120001.

Code 0950327091 can be used with motors 37M2200001, 37M1230000 and 37M5120000.

A bracket suitable for motor 37M4200001 is not provided.

### FOOT MODEL A

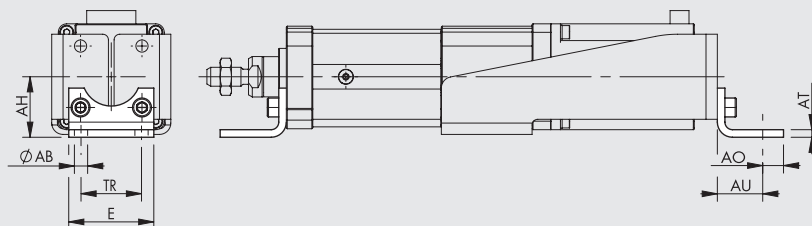

#### STEEL

Code	Ø	ØAB	AH	AO	AT	AU	TR	E	Weight [g]	$F_{max}$ [N]
W0950322001	32	7	32	11	4	24	32	45	76	1600

Note: Individually packed with 2 screws.

### FEMALE HINGE - MODEL B

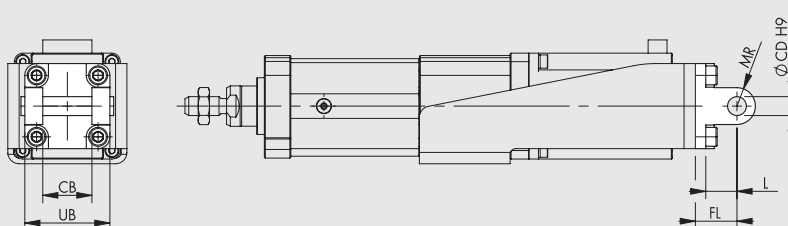

#### ALUMINIUM

Code	Ø	UB	CB	FL	ØCD	MR	L	Weight [g]	$F_{max}$ [N]
W0950322003	32	45	26	22	10	10	12	116	800

Note: Supplied with 4 screws, 4 washers, 2 snap rings and 1 pin.

#### STEEL

Code	Ø	UB	CB	FL	ØCD	MR	L	Weight [g]	$F_{max}$ [N]
W095E322003	32	45	26	22	10	10	13	348	1600

Note: Supplied with 4 screws, 4 washers, 2 snap rings and 1 pin.

**MALE HINGE - MODEL BA**

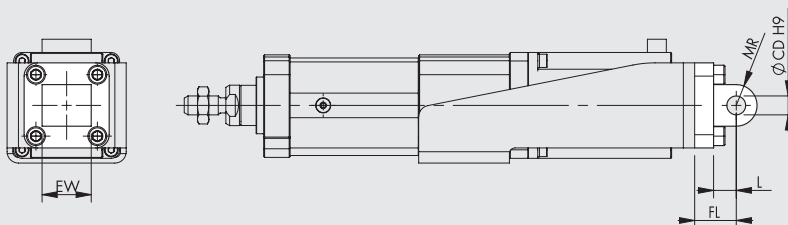

**ALUMINIUM**

Code	Ø	EW	FL	MR	ØCD	L	Weight [g]	Fmax [N]
W0950322004	32	26	22	10	10	13	94	800

Note: Supplied with 4 screws.

**STEEL**

Code	Ø	EW	FL	MR	ØCD	L	Weight [g]	Fmax [N]
W095E322004	32	26	22	10	10	13	282	1600

Note: Supplied with 4 screws.

**ARTICULATED MALE HINGE - MODEL BAS**

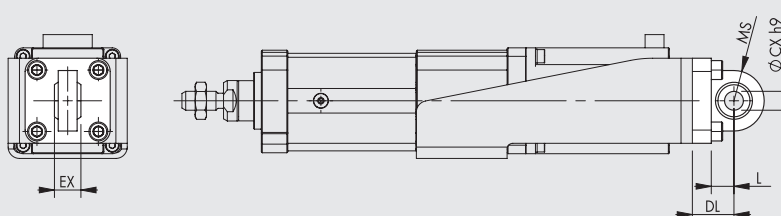

**ALUMINIUM**

Code	Ø	DL	MS	L	ØCX	EX	Weight [g]	Fmax [N]
W0950322006	32	22	16	12	10	14	106	800

Note: Supplied with 4 screws, 4 washers.

**STEEL**

Code	Ø	DL	MS	L	ØCX	EX	Weight [g]	Fmax [N]
W095E322006	32	22	15	14	10	14	318	1600

Note: Supplied with 4 screws, 4 washers.

**CETOP HINGE FOR MODEL B - MODEL GI**

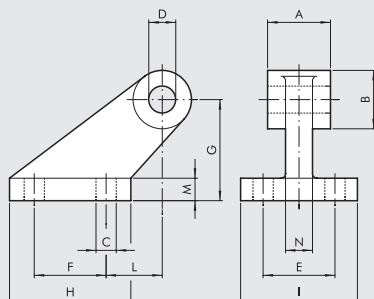

**ALUMINIUM**

Code	Ø	A	B	C	D	E	F	G	H	I	L	M	N	Weight [g]	Fmax [N]
W0950322008	32	26	19	7	10	25	20	32	37	41	18	8	10	96	800

Note: Supplied with 4 screws, 4 washers.

**COUNTER-HINGE FOR MODEL B - MODEL GS**

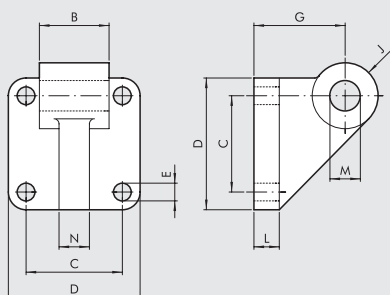

**ALUMINIUM**

Code	Ø	B	C	D	E	G	J	L	M	N	Weight [g]	Fmax [N]
W0950322108	32	26	32.5	45	7	32	11	10	10	10	106	800

Note: Supplied with 4 screws, 4 washers.

ISO 15552 COUNTER-HINGE FOR MODEL B - MODEL AB7

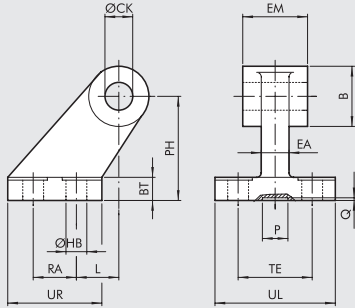

ALUMINIUM

Code	∅	EM	B	∅HB	∅CK	TE	RA	PH	UR	UL	L	BT	EA	P	Q	Weight [g]	Fmax [N]
W0950322017	32	26	20	6.6	10	38	18	32	31	51	3	8	10	21	3	60	800

STEEL

Code	∅	EM	B	∅HB	∅CK	TE	RA	PH	UR	UL	L	BT	EA	P	Q	Weight [g]	Fmax [N]
W095E322017	32	26	20	6.6	10	38	18	32	31	51	3	8	10	20	5	180	1600

FRONT FLANGE - MODEL C

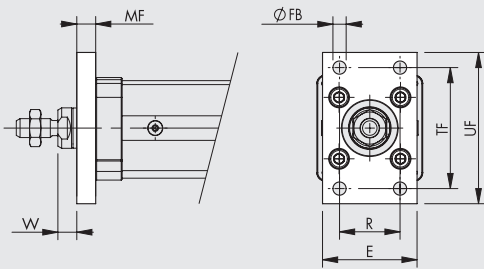

Code	∅	TF	UF	E	MF	R	∅FB	W	Weight [g]	Fmax [N]
W0950322002	32	64	80	50	10	32	7	16	246	1600

Note: Supplied with 4 screws.

ROD NUT - MODEL S

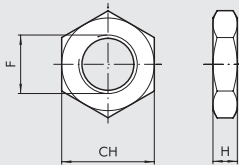

Code	∅	F	H	CH	Weight [g]
0950322010	32	M10x1.25	6	17	6

Note: Individually packed

FORK MODEL GK-M

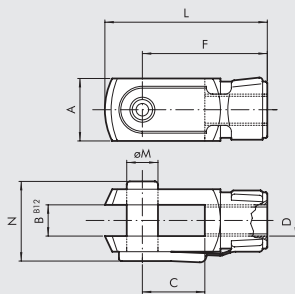

Code	∅	∅M	C	B	A	L	F	D	N	Weight [g]
W0950322020	32	10	20	10	20	52	40	M10x1.25	26	92

Note: Individually packed

ROD EYE - MODEL GA-M

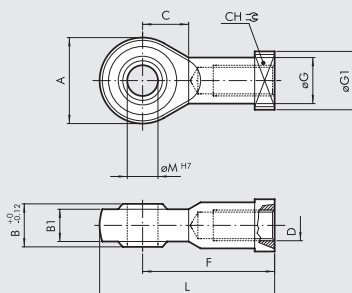

Code	∅	∅M	C	B1	B	A	L	F	D	∅G	CH	∅G1	Weight [g]
W0950322025	32	10	15	10.5	14	28	57	43	M10x1.25	15	17	19	78

Note: Individually packed

**SELF ALIGNING ROD COUPLER - MODEL GA-K**

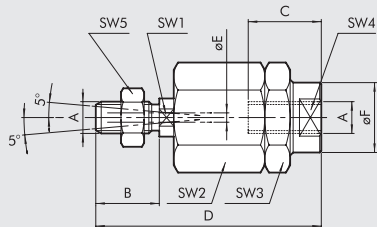

Code	Ø	A	B	C	D	øF	øE	SW1	SW2	SW3	SW4	SW5	Weight [g]
W0950322030	32	M10x1.25	20	20	71	22	4	12	30	30	19	17	216

Note: Individually packed

**GREASING NEEDLE**

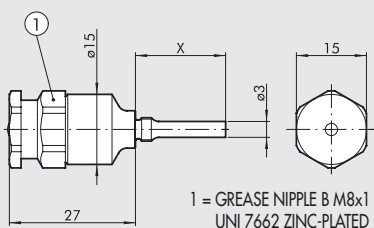

Code	Ø	X
0950327108	32	12

Note: Individually packed

**GREASE**

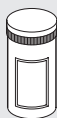

Code	Description	Weight [g]
9910506	Tube of RHEOLUBE 363 AX1 grease	400

**RETRACTABLE SENSOR**

**SENSOR, SQUARE TYPE**   
Latest generation,  
secure fixing

**SENSOR, OVAL TYPE**   
Traditional

For codes and technical data, see **chapter A6**.

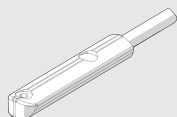
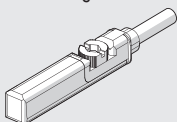

**POSITION SENSORS**

LTS

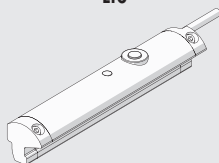

For technical data and usage strokes see **chapter A6**. 

**NOTES**

GUIDE UNIT

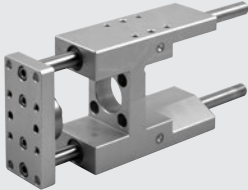
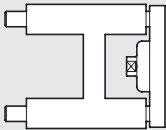
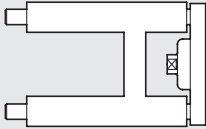
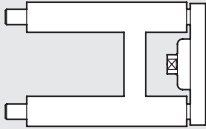
Version		Code	Bore	Type
	Sliding on bronze bushings (GDH)	W0700322...	32	UNIT MW DH 032...
				
				
		<p><b>Note: The guide units must only be used with anti-rotation cylinders.</b>                      To complete the type and code, add the 3-digit stroke (e.g. 50=050)                      For technical data and dimensions, see <b>chapter A1</b>.</p>		
	Sliding on ball bearing (GDM)	W0700323...	32	UNIT MW DM 032...
				
				
		<p><b>Note: The guide units must only be used with anti-rotation cylinders.</b>                      To complete the type and code, add the 3-digit stroke (e.g. 50=050).                      For technical data and dimensions, see <b>chapter A1</b>.</p>		

DRIVES



For motor-drive couplings see table on page A5.48 

SPARE PARTS

ELECTRIC MOTORS



For motor-drive couplings see table on page A5.48 

NOTES