

Flow Grippers for Highly Structured Surfaces SCG-HSS

Suction rate from 270 l/min to 650 l/min

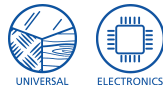

Suitability for industry specific applications



Flow Grippers for Highly Structured Surfaces SCG-HSS

Applications

- Compact flow gripper for handling dimensionally stable workpieces with highly structured surfaces such as assembled printed circuit boards
- Process safe and gentle handling with minimum surface pressure even for workpieces with openings and low degree of occupancy
- Protection against uncontrolled electrostatic discharge of sensitive components through ESD compliant design
- Teach-in of the respective surface contour without additional set-up times

Design

- Basic model made of non-anodized aluminum with integrated compressed air driven vacuum generation (1)
- Suitable for side mounting (2)
- Flexibly adjustable gripping surface through pins with pneumatic fixation (3)
- Exhaust duct for controlled conduction of the air sucked in (4)
- Compressed air connection for vacuum generation (suction) (5)
- Compressed air connections for extending and fixing the pins and connection for vacuum sensing (6)

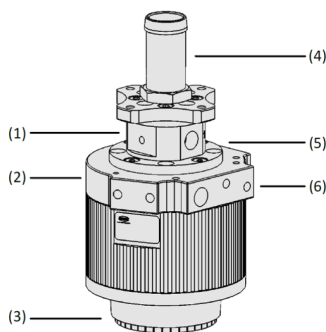

System design Flow Grippers for Highly Structured Surfaces SCG-HSS



Flow grippers SCG-HSS for handling assembled printed circuit boards

Product highlights

- Very good sealing on strongly structured surfaces due to flexibly adjustable pin curtain
- High suction capacity with minimum air consumption for low operating costs
- Protection of sensitive workpieces by controlled discharge of electrostatic charges
- Compact, lightweight gripper is suitable for small components or for large components when combining several grippers
- Highest process reliability at high throughput due to handling true to position and layer

Flow Grippers for Highly Structured Surfaces SCG-HSS

Suction rate from 270 l/min to 650 l/min

Designation code Flow Grippers for Highly Structured Surfaces SCG-HSS

SCG-HSS	–	1xE100	–	AR	–	25	–	47
1		2		3		4		5

1 – Abbreviated designation

Code	Version
SCG-HSS	SCG-HSS

2 – Performance class of ejector

Code	Performance class of ejector
1xE100	1xE100

3 – Design

Code	Type
AR	Exhaust air duct axial

4 – Gripper stroke

Code	Stroke in mm
25	25

5 – Suction area

Code	Diameter in mm
47	ø 47

The flow gripper SCG-HSS is delivered assembled. The product consists of:

- Gripper type SCG-HSS with integrated vacuum generator

Available spare parts: pins

Available accessories: exhaust duct, mounting set, compressed air hoses, plug-in screw unions

Ordering data Flow Grippers for Highly Structured Surfaces SCG-HSS

Type	Part no.
SCG-HSS 1xE100 AR 25 47	10.01.30.01058

Technical data Flow Grippers for Highly Structured Surfaces SCG-HSS

Type	Add. function ejector	Performance class	Operating temperature	Weight [g]
SCG-HSS 1xE100 AR 25 47	Exhaust air connection axial	E100	5 ... 50 °C	520

Flow Grippers for Highly Structured Surfaces SCG-HSS

Suction rate from 270 l/min to 650 l/min

Design data Flow Grippers for Highly Structured Surfaces SCG-HSS

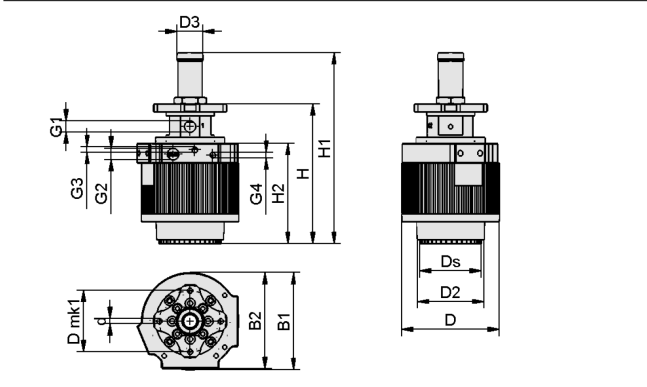

Flow Grippers for Highly Structured Surfaces SCG-HSS

Suction rate from 270 l/min to 650 l/min

Design data Flow Grippers for Highly Structured Surfaces SCG-HSS

Type	B1 [mm]	B2 [mm]	D [mm]	d [mm]	D2 [mm]	D3 [mm]	D mk1 [mm]	Ds [mm]	G1	G2	G3	G4	H [mm]	H1 [mm]	H2 [mm]
SCG-HSS 1xE100 AR 25 47	73	72	73.0	4	50	19.5	46	47	G1/8"-F	G1/8"-F	M5-F	M5-F	105	143.5	75.5

Multimedia product presentation

Medium	Link
Product video	https://vimeo.com/691838469 https://vimeo.com/516722657 https://vimeo.com/415813528