

GRIPPER WITH TWO PARALLEL LONG-STROKE JAWS, SERIES P4



These are grippers with 2 parallel long-stroke jaws. The mechanical design makes them suitable for clamping bulky parts. All grippers, except for the smallest ones, can mount a retracting magnetic proximity sensor.



ACTUATORS

GRIPPER WITH TWO PARALLEL LONG-STROKE JAWS – SERIES P4

TECHNICAL DATA		P4-10	P4-12	P4-16	P4-25	P4-30
Operating pressure	bar			3 to 7		
	MPa			0.3 to 0.7		
	psi			43 to 101		
Operating temperature	°C			-10 to +80		
Maximum operating frequency	cycles/s			1		
Fluid		20 μ m filtered, lubricated or unlubricated air; lubrication if used, it must be continuous				
Bore	mm	2 x 10	2 x 12	2 x 16	2 x 30	2 x 30
Single jaw stroke	mm	5	10	15	30	60
Clamping force at 6.3 bar 20 mm from the top surface during opening and closing	N	30	45	75	280	280
Weight	kg	0.18	0.3	0.5	2.95	3.7

TABLE OF CLAMPING FORCES FOR VARIOUS POINTS OF APPLICATION

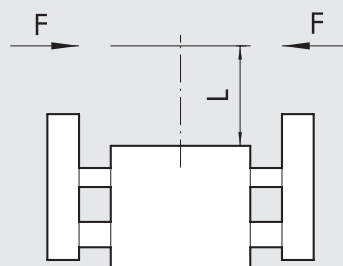

DIMENSIONS OF GRIPPER P4-10

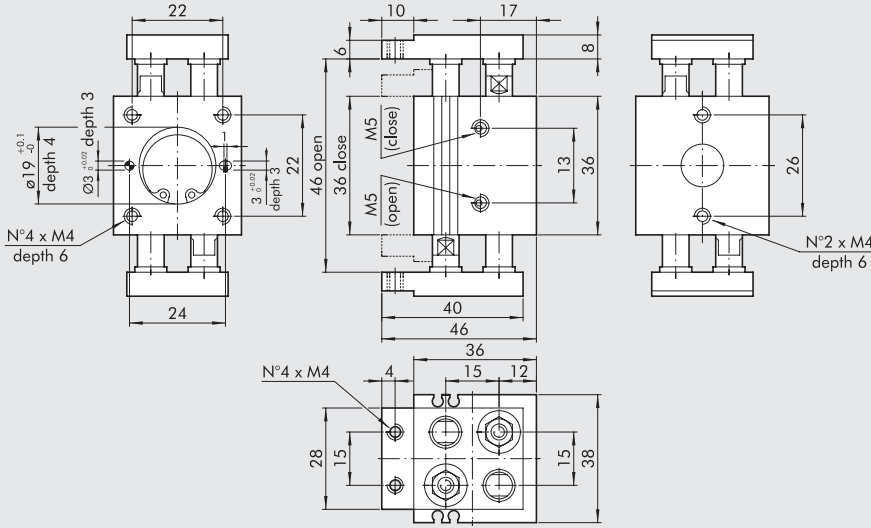

Code	Description
W1580100200	Gripper with 2 parallel long-stroke jaws P4-10

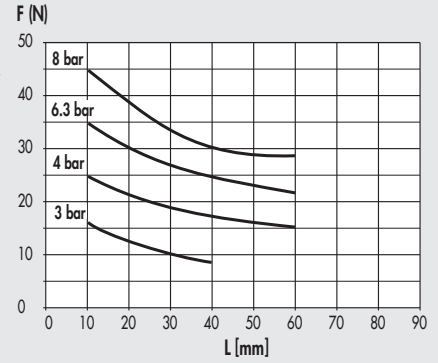

DIMENSIONS OF GRIPPER P4-12

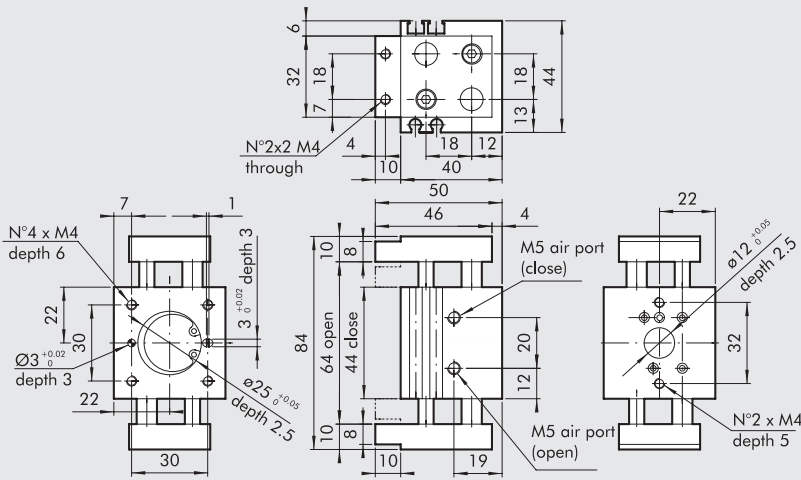

Code	Description
W1580120200	Gripper with 2 parallel long-stroke jaws P4-12

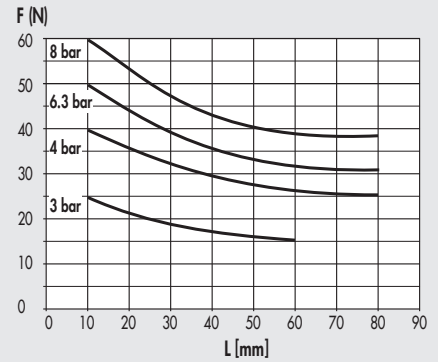

DIMENSIONS OF GRIPPER P4-16

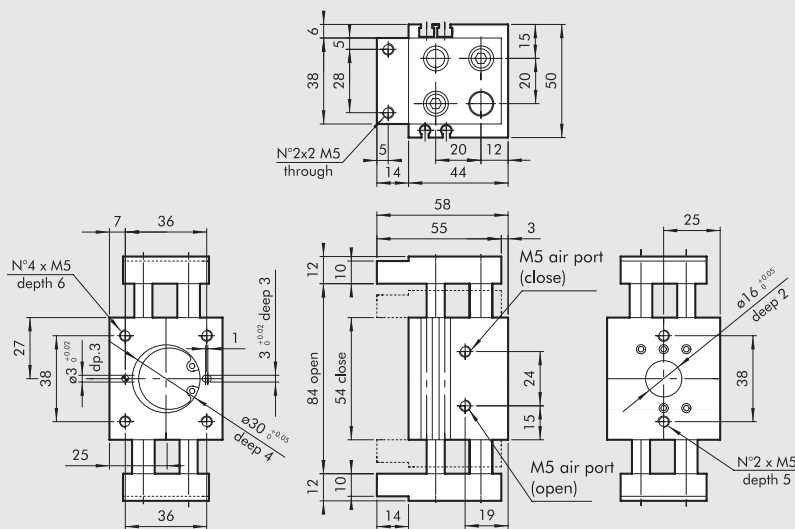

Code	Description
W1580160200	Gripper with 2 parallel long-stroke jaws P4-16

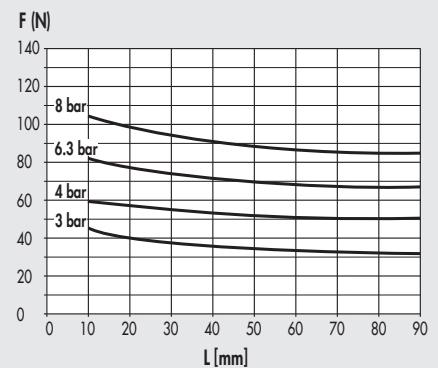

DIMENSIONS OF GRIPPER P4-25

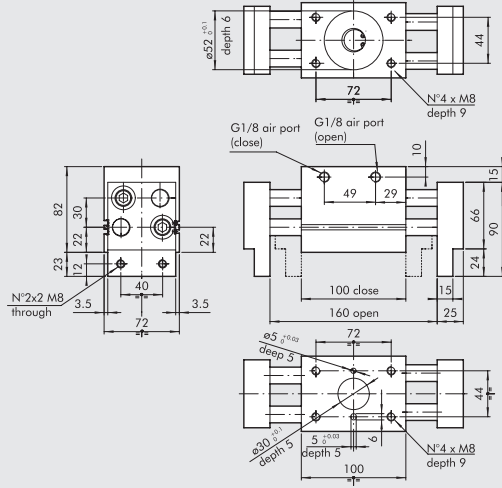

Code	Description
W1580250200	Gripper with 2 parallel long-stroke jaws P4-25

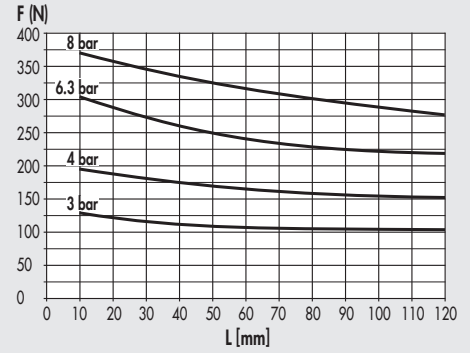

DIMENSIONS OF GRIPPER P4-30

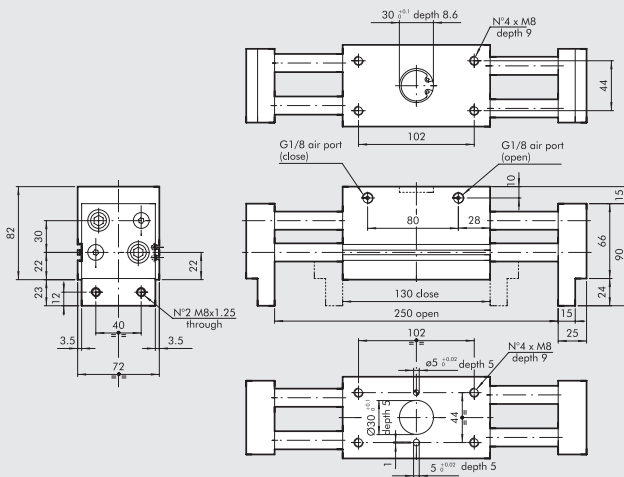

Code	Description
W1580300200	Gripper with 2 parallel long-stroke jaws P4-30

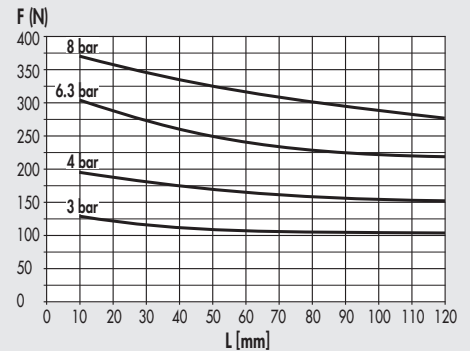

ACCESSORIES

SENSOR Ø 4 FOR P4 10-30

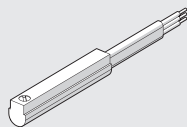

For codes and technical data, see [chapter A6](#).

RETRACTABLE SENSOR FOR P4-12-30

SENSOR, SQUARE TYPE
Latest generation,
secure fixing

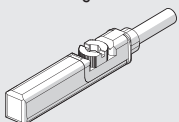

SENSOR, OVAL TYPE
Traditional

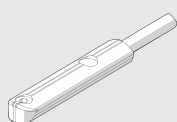

For codes and technical data, see [chapter A6](#).