

GRIPPER WITH TWO HINGED JAWS – SERIES P7

ACTUATORS

GRIPPER WITH TWO HINGED JAWS – SERIES P7

Bores 16, 20, 32 and 50 mm.
All grippers are magnetic with slots in the body with retracting sensors.

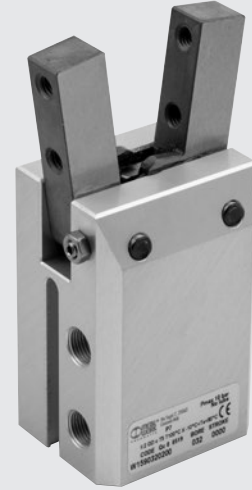

TECHNICAL DATA		P7-16	P7-20	P7-32	P7-50
Operating pressure	bar	2 to 10	2 to 10	2 to 10	2 to 10
	MPa	0.2 to 1	0.2 to 1	0.2 to 1	0.2 to 1
	psi	29 to 145	29 to 145	29 to 145	29 to 145
Fluid	20 µm filtered, lubricated or unlubricated air; lubrication if used, it must be continuous				
Temperature range	°C	-10 to +80			
Maximum opening angle of single jaw		15° 30'	16° 30'	16°	8° 30'
Clamping force at 6.3 bar 20 mm from the centre of rotation of the jaws, during opening and closing	N	27	50	120	380
Weight	kg	0.12	0.19	0.5	1.6

TABLE OF CLAMPING FORCES FOR VARIOUS POINTS OF APPLICATION

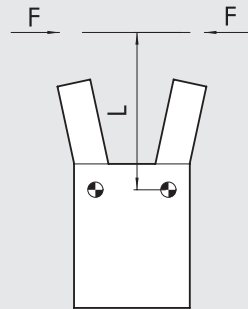

DIMENSIONS OF GRIPPER P7-16

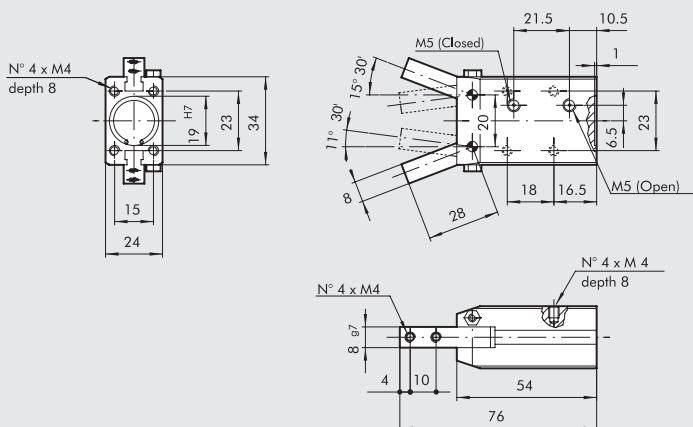

Code **W1590160200** Description **Gripper with 2 hinged jaws P7-16**

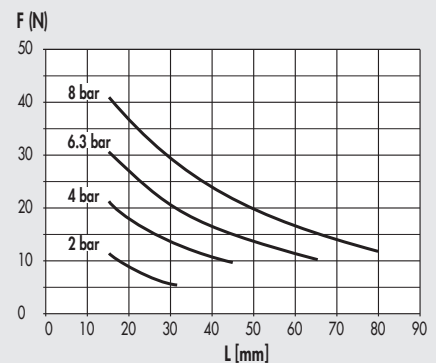

DIMENSIONS OF GRIPPER P7-20

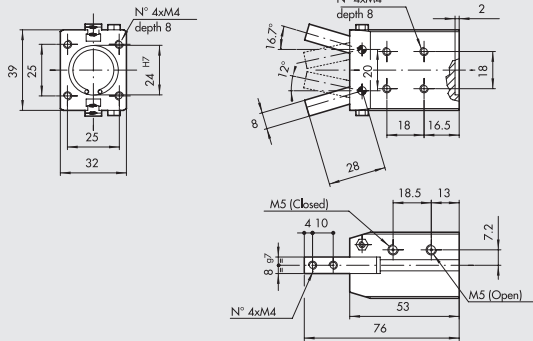

Code W1590200200 **Description** Gripper with 2 hinged jaws P7-20

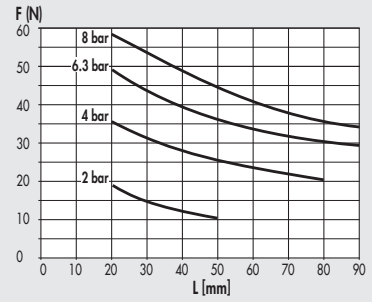

DIMENSIONS OF GRIPPER P7-32

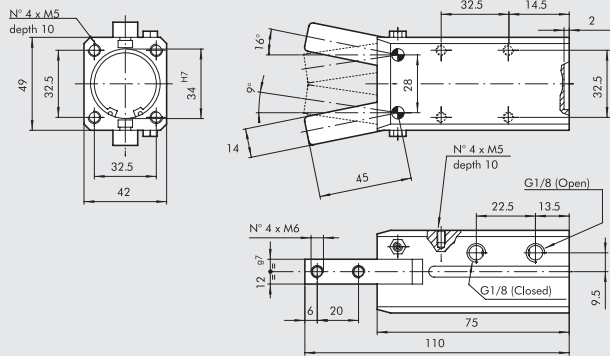

Code W1590320200 **Description** Gripper with 2 hinged jaws P7-32

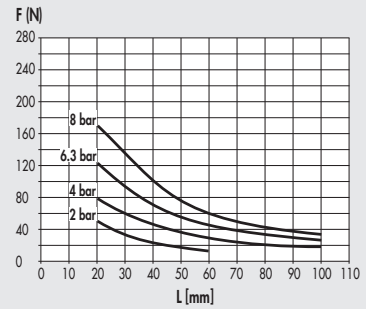

DIMENSIONS OF GRIPPER P7-50

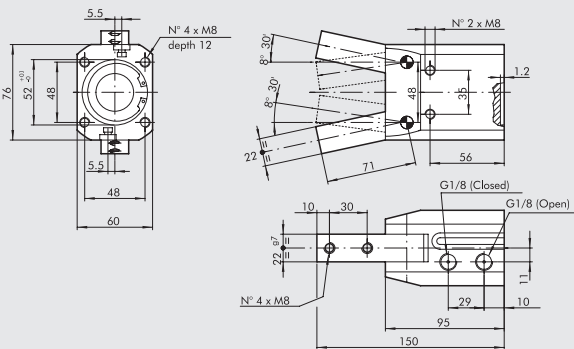

Code W1590500200 **Description** Gripper with 2 hinged jaws P7-50

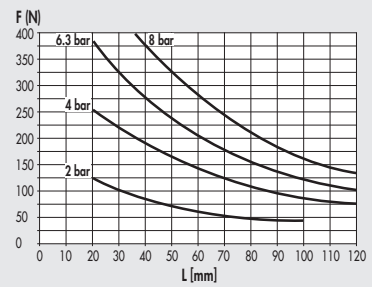

ACCESSORIES

RETRACTABLE SENSOR

SENSOR, SQUARE TYPE
Latest generation,
secure fixing

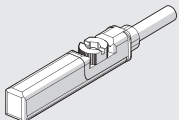

SENSOR, OVAL TYPE
Traditional

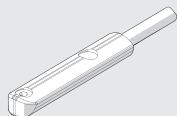

For codes and technical data, see chapter A6.