

GRIPPER 180° WITH TWO HINGED JAWS - SERIES P9

- Toggle-type pivoted grippers, with adjustable opening angle.
- High clamping forces.
- Body made of hard anodized aluminium, jaws and moving parts made of tempered steel.
- Bottom or side fixing.
- All sizes come with magnets and sensor slots.



TECHNICAL DATA		P9-32	P9-40
Operating pressure	bar		2 to 8
	MPa		0.2 to 0.8
	psi		29 to 116
Temperature range	°C		-10 to +80
Fluid		Filtered, lubricated or unlubricated air; lubrication if used, it must be continuous	
Bores	mm	32	40
Jaw opening angle		Adjustable 180°	
Clamping force at 6.3 bar 40 mm from the jaw pivot during opening and closing	N	160	260
Weight	kg	0.85	1.5

TABLE OF CLAMPING FORCES FOR VARIOUS POINTS OF APPLICATION

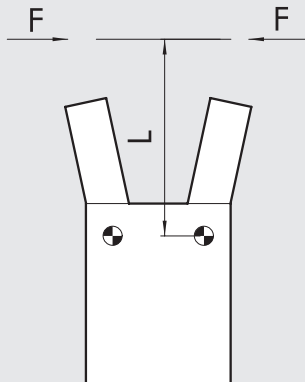

DIMENSIONS OF GRIPPER P9-32

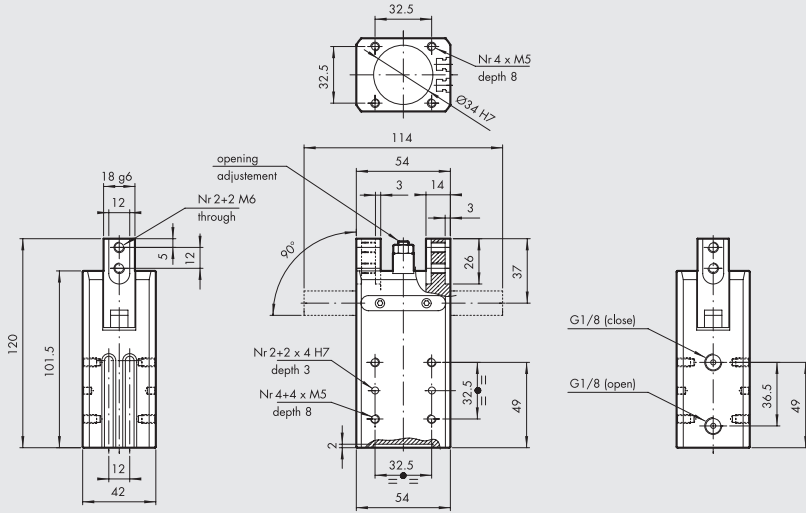

Code	Description
W1530320180	Hinged gripper P9-32

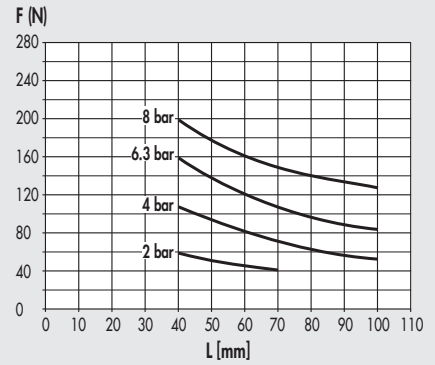

DIMENSIONS OF GRIPPER P9-40

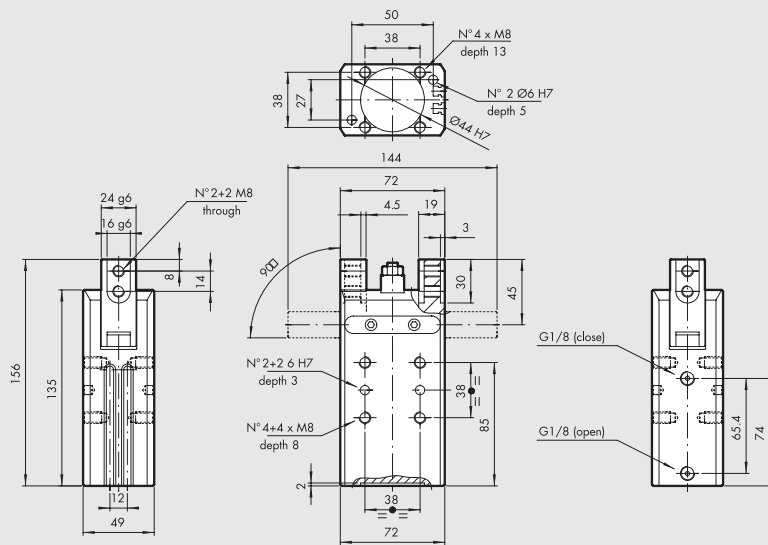

Code	Description
W1530400180	Hinged gripper P9-40

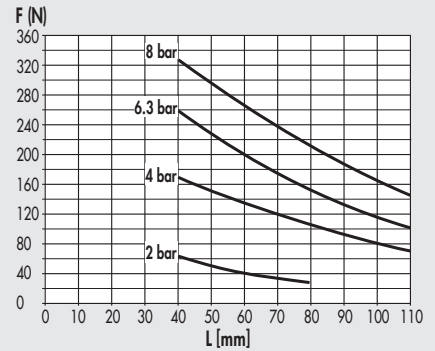

ACCESSORIES

RETRACTABLE SENSOR

SENSOR, SQUARE TYPE
Latest generation,
secure fixing

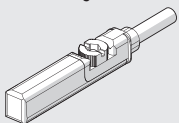

SENSOR, OVAL TYPE
Traditional

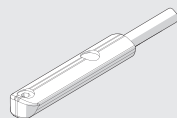

For codes and technical data, see chapter A6.