

COMPACT GUIDED CYLINDER SERIES MULTIFIX

This functional and heavy-duty cylinder is a further development of the well-known and proven CMPG series. It is designed to allow the fixing on multiple sides using different methods, compressed air supply on both sides and double sensor slots, on both the upper and lower side.

The bushing guides of the piston rods are fitted directly into the anodized aluminium alloy cylinder liner.

There are two possible guiding solutions: sintered bronze bushings coupled with piston rods made of ground chromed carbon steel or ball recirculating bushings coupled with hardened, chromed and ground steel.

A silenced version with elastic end-stroke elements and a version with pneumatic cushioning with adjustable pins to control the braking are also available.



TECHNICAL DATA		Ø16	Ø20	Ø25	Ø32	Ø40	Ø50	Ø63	Ø80
Operating pressure	bar	1 to 10							
	MPa	0.1 to 1							
Temperature range	psi	14.5 to 145							
	°C	-20 to +80							
Fluid	°F	14 to 176							
	Version	Unlubricated air. Lubrication, if used, must be continuous. With bronze bushings, with ball recirculating bearings Silenced or with pneumatic cushioning							
Magnet for sensors		Yes							
Maximum impact energy	silenced J	0.06	0.14	0.2	0.4	0.6	0.9	1.3	2
	with pneumatic cushioning J	See diagram page A1.154							
Inrush pressure	with bronze bearings bar	0.8	0.8	0.8	0.5	0.5	0.4	0.4	0.4
	with ball recirculating bearings bar	0.6	0.6	0.6	0.4	0.4	0.3	0.3	0.3
Forces generated in thrust/retraction		See cylinder "General technical data" at the beginning of the chapter							

WEIGHTS [kg] - STROKES

SILENCED VERSION

Bore	Strokes [mm]															
	10	20	25	30	40	50	75	100	125	150	175	200	250	300	350	400
16	0.3	0.35	-	0.4	0.45	0.5	0.7	0.85	1	1.15	1.3	1.45	1.6	-	-	-
20	-	0.55	-	0.65	0.75	0.85	1.15	1.35	1.55	1.75	1.95	2.15	2.5	2.9	3.3	3.7
25	-	0.9	-	1.05	1.2	1.35	1.9	2.25	2.55	2.85	3.15	3.35	4	4.35	4.7	5
32	-	-	1.5	-	-	1.85	2.25	2.6	3	3.35	3.7	4.05	5.2	5.9	6.6	7.3
40	-	-	1.75	-	-	2.15	2.55	2.95	3.35	3.75	4.15	4.55	5.8	6.6	7.4	8.2
50	-	-	2.56	-	-	3.18	4.26	4.89	5.51	6.13	6.75	7.37	8.90	10.14	11.38	12.73
63	-	-	3.17	-	-	3.90	5.10	5.84	6.57	7.31	8.04	8.78	10.63	12.11	13.58	15.05
80	-	-	5	-	-	5.89	7.60	8.46	9.32	10.18	11.14	11.91	13.94	15.66	18.35	19.11

Other strokes on request but with the same cylinder dimensions as the standard stroke immediately above.

VERSION WITH PNEUMATIC CUSHIONING

Bore	Strokes [mm]											
	25	50	75	100	125	150	175	200	250	300	350	400
16	0.55	0.65	0.8	0.95	1.2	1.35	1.5	1.65	1.8	-	-	-
20	0.8	1	1.25	1.5	1.75	2	2.25	2.5	2.75	3	3.25	3.5
25	1.3	1.6	2	2.4	2.7	3	3.3	3.6	4.2	4.8	5.4	6
32	1.8	2.1	2.5	2.9	3.3	3.7	4.1	4.5	5.3	6.1	6.9	7.7
40	2.1	2.5	2.9	3.4	3.8	4.2	4.6	5	6.1	7.1	8.2	9.3
50	3.35	3.70	4.79	5.41	6.03	6.65	7.27	7.90	9.42	10.66	11.90	13.53
63	3.87	4.07	5.80	6.54	7.28	8.01	8.75	9.48	11.29	12.71	14.18	15.65
80	5.82	6.85	8.59	9.46	10.91	11.20	12.08	12.95	15.11	16.96	19.33	20.68

COMPONENTS SILENCED VERSION

- ① BODY: anodized extruded aluminium alloy
 - ② PISTON ROD: grinded chromed steel
 - ③ REAR BASE: anodized aluminium alloy
 - ④ FRONT BASE: anodized aluminium alloy
 - ⑤ PISTON: aluminium alloy
 - ⑥ MAGNET: plastoferrite
 - ⑦ PISTON GASKET: NBR or polyurethane
 - ⑧ GASKET O-Ring: NBR
 - ⑨ FLANGE: anodized aluminium alloy
 - ⑩ ELASTIC BUFFER: polyurethane
 - ⑪ THREADED PLUG: nickel-plated brass with O-Ring
- N.B.: when using side compressed air supplies, unscrew the caps and tighten them onto the threads of the compressed air supplies on the upper side.

Version with bronze bushings

- ⑫ GUIDE ROD: grinded chromed steel
- ⑬ SLIDE BUSHING: sintered bronze
- ⑭ WIPER RING: NBR

Version with ball recirculating bearings

- ⑮ GUIDE ROD: tempered and chromed chrome steel
- ⑯ BALL RECIRCULATING BEARING

Version with ball recirculating bearings

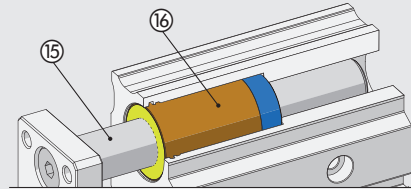

Version with bronze bushings

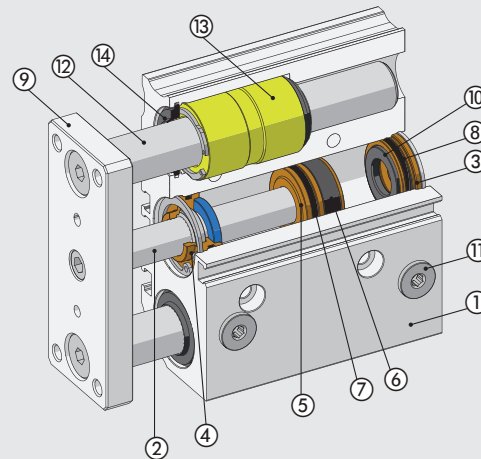

COMPONENTS VERSION WITH PNEUMATIC CUSHIONING

- ① BODY: anodized extruded aluminium alloy
 - ② PISTON ROD: grinded chromed steel
 - ③ REAR BASE: anodized aluminium alloy
 - ④ FRONT BASE: anodized aluminium alloy
 - ⑤ PISTON: aluminium alloy
 - ⑥ MAGNET: plastoferrite
 - ⑦ PISTON GASKET: NBR or polyurethane
 - ⑧ GASKET O-Ring: NBR
 - ⑨ FLANGE: anodized aluminium alloy
 - ⑩ CUSHIONING GASKET: NBR
 - ⑪ CUSHIONING NEEDLE: brass
 - ⑫ THREADED PLUG: nickel-plated brass with O-Ring
- N.B.: when using side compressed air supplies, unscrew the caps and tighten them onto the threads of the compressed air supplies on the upper side.

Version with bronze bushings

- ⑬ GUIDE ROD: grinded chromed steel
- ⑭ SLIDE BUSHING: sintered bronze
- ⑮ WIPER RING: NBR

Version with ball recirculating bearings

- ⑯ GUIDE ROD: tempered and chromed chrome steel
- ⑰ BALL RECIRCULATING BEARING

Version with ball recirculating bearings

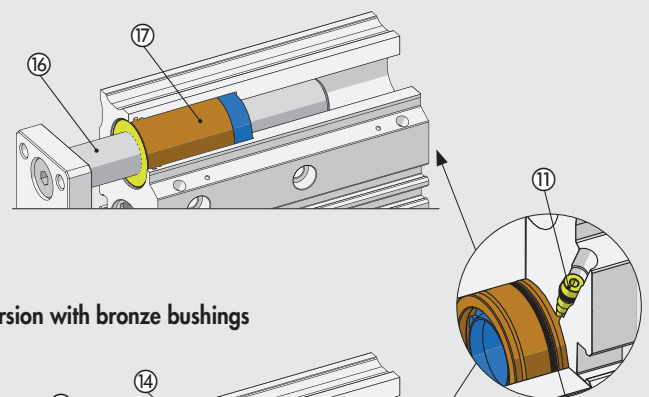

Version with bronze bushings

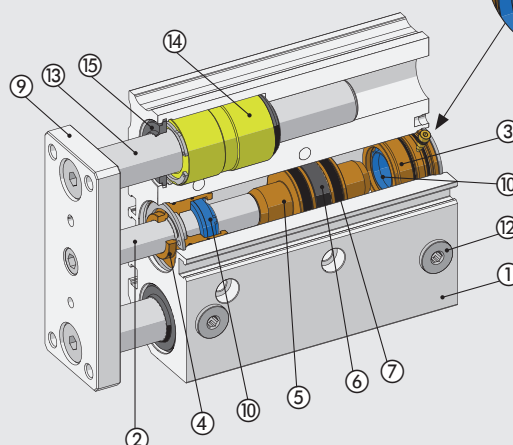
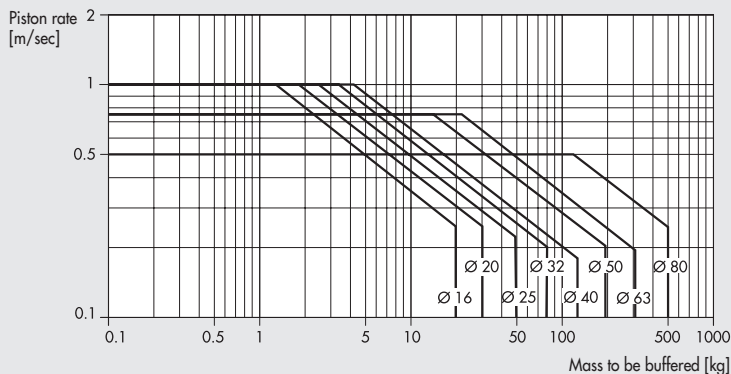

DIAGRAM OF SPEED AND MAXIMUM CUSHIONABLE LOAD

For the cylinder to reach the end-of-stroke position without intense or repeated impact which would damage it, it is necessary to annul the kinetic energy of the moving mass and the work generated.

The maximum cushionable load depends on the traversing speed and the absorption of the air buffer supplied standard with the various cylinders.

The diagram shows the speeds and cushionable mass for the various diameters at a pressure of 6 bar.



MAXIMUM SIDE LOAD

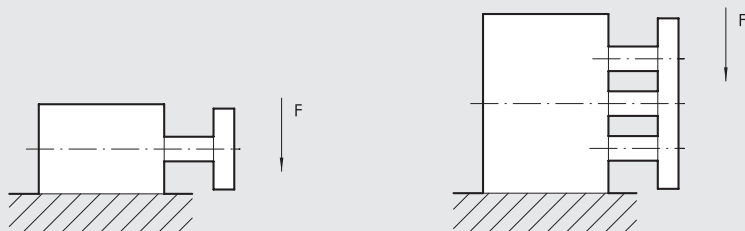

Ø [mm]	Guide unit	Strokes [mm]																
		10	20	25	30	40	50	75	100	125	150	175	200	250	300	350	400	
16	Bushes	40	35	32	29	25	24	25	20	19	18	16	13	10	-	-	-	
	Balls	35	38	33	30	29	28	35	24	21	19	16	13	10	-	-	-	
20	Bushes	-	40	35	33	32	30	63	52	49	40	36	32	26	22	14	10	
	Balls	-	40	34	32	31	28	55	50	45	38	34	30	25	21	12	8	
25	Bushes	-	70	60	50	40	36	80	70	65	55	50	45	35	25	18	10	
	Balls	-	70	60	50	40	36	65	55	62	52	45	42	30	23	15	6	
32	Bushes	-	-	140	-	-	120	150	120	110	90	80	70	50	40	20	10	
	Balls	-	-	120	-	-	100	180	140	125	120	110	90	80	60	30	15	
40	Bushes	-	-	140	-	-	120	150	120	110	90	80	70	50	40	20	10	
	Balls	-	-	120	-	-	100	180	140	125	120	110	90	80	60	30	15	
50	Bushes	-	-	180	-	-	150	200	170	150	140	130	100	70	55	25	15	
	Balls	-	-	125	-	-	110	220	190	185	180	160	150	130	110	60	40	
63	Bushes	-	-	180	-	-	150	200	170	150	140	130	100	70	55	25	15	
	Balls	-	-	125	-	-	110	220	190	185	180	160	150	130	110	65	40	
80	Bushes	-	-	250	-	-	190	250	220	200	150	130	125	95	70	30	20	
	Balls	-	-	170	-	-	170	320	300	280	250	200	190	160	140	70	60	

Centre of gravity distance from the front plane = 50 mm

N.B.: Forces are expressed in N

MAXIMUM TORQUE ON PLATE

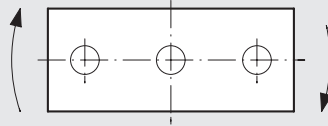

Ø [mm]	Guide unit	Strokes [mm]															
		10	20	25	30	40	50	75	100	125	150	175	200	250	300	350	400
16	Bushes	0.71	0.60	0.54	0.50	0.44	0.39	0.71	0.60	0.52	0.45	0.41	0.37	0.31	-	-	-
	Balls	1.02	0.76	0.62	0.61	1.02	0.89	0.67	0.54	0.44	0.38	0.33	0.29	0.24	-	-	-
20	Bushes	-	1.08	1.03	0.96	0.85	0.77	1.94	1.68	1.48	1.32	1.19	1.09	0.93	0.80	0.71	0.64
	Balls	-	1.30	1.13	1.06	2.24	2.00	1.57	1.29	1.38	1.21	1.06	0.96	0.78	0.67	0.58	0.50
25	Bushes	-	1.81	1.67	1.60	1.42	1.29	3.05	2.65	2.33	2.08	1.88	1.72	1.46	1.28	1.12	1.01
	Balls	-	2.17	2.01	1.80	3.47	3.11	2.45	2.03	2.11	1.83	1.63	1.45	1.19	1.01	0.88	0.76
32	Bushes	-	-	6.54	-	-	5.28	5.86	5.12	4.55	4.10	3.72	3.41	2.93	2.55	2.27	2.04
	Balls	-	-	6.13	-	-	5.04	5.26	4.65	6.53	5.96	5.49	5.08	4.42	3.89	3.48	3.13
40	Bushes	-	-	7.21	-	-	5.83	6.46	5.64	5.02	4.51	4.10	3.76	3.22	2.82	2.50	2.26
	Balls	-	-	6.75	-	-	5.55	5.79	5.11	7.19	6.57	6.05	5.59	4.86	4.28	3.82	3.45
50	Bushes	-	-	13.39	-	-	11.12	12.36	10.92	9.79	8.86	8.10	7.46	6.43	5.65	5.05	4.56
	Balls	-	-	9.45	-	-	7.85	10.12	9.00	11.95	11.02	10.12	9.39	8.19	7.23	6.45	5.80
63	Bushes	-	-	15.14	-	-	12.46	13.91	12.26	11.02	9.98	9.13	8.40	7.25	6.38	5.69	5.14
	Balls	-	-	10.51	-	-	8.73	11.33	10.03	13.39	12.26	11.33	10.51	9.11	8.03	7.15	6.43
80	Bushes	-	-	22.55	-	-	19.15	23.58	21.11	19.15	17.51	16.06	14.93	12.97	11.53	10.30	9.38
	Balls	-	-	15.55	-	-	23.99	23.38	21.21	19.46	17.81	16.48	15.24	13.28	11.63	10.30	9.20

N.B.: Forces are expressed in Nm

TORSIONAL BACKLASH

Torsional backlash ϵ with piston rods retracted and without applied loads.

Torsional backlash ϵ [°]	Ø [mm]							
	16	20	25	32	40	50	63	80
With bronze bushings	±0.07	±0.06	±0.06	±0.05	±0.05	±0.04	±0.04	±0.03
With ball recirculating bearings	±0.05	±0.04	±0.04	±0.03	±0.03	±0.03	±0.03	±0.03

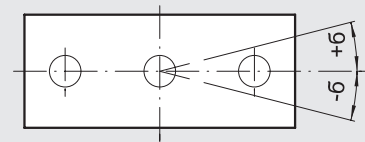

MOUNTING OPTIONS

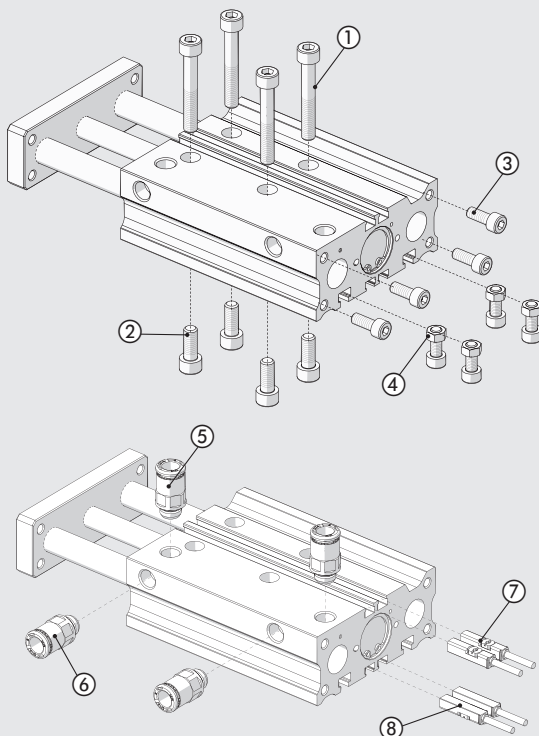

- ① Fixing with through screws
- ② Fixing with threaded holes
- ③ Fixing from the back side, using threaded holes
- ④ Fixing with DIN 834 hexagonal nuts inserted into the T-slots

Ø	Hexagonal nut DIN 834 (UNI 5588)		
	D	m	S
16	M4	3.2	7
20	M5	4	8
25	M5	4	8
32	M6	5	10
40	M6	5	10
50	M8	6.5	13
63	M10	8	17
80	M12	10	19

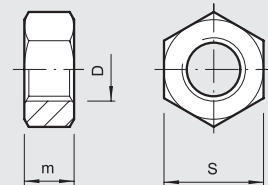

- ⑤ Compressed air supply on the upper side
- ⑥ Compressed air supply on the lateral side
- ⑦ Two sensor slots on the upper side
- ⑧ Two sensor slots on the lower side

STOPPER FUNCTIONS

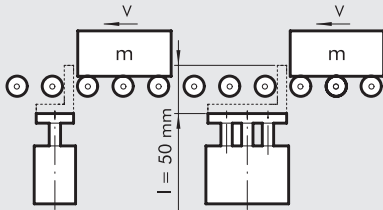

The graph refers to a cylinder with a maximum stroke of 50 mm and with bushing guides.

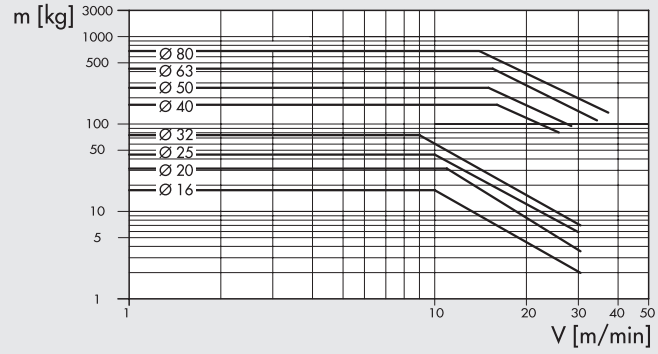

N.B.: The version with a ball bushing must not be used as a stopper.

LIFTING FUNCTIONS

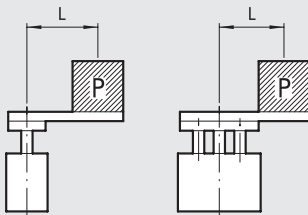

The graph refers to cylinders with a stroke of up to 50 mm with a ball recirculation guide.

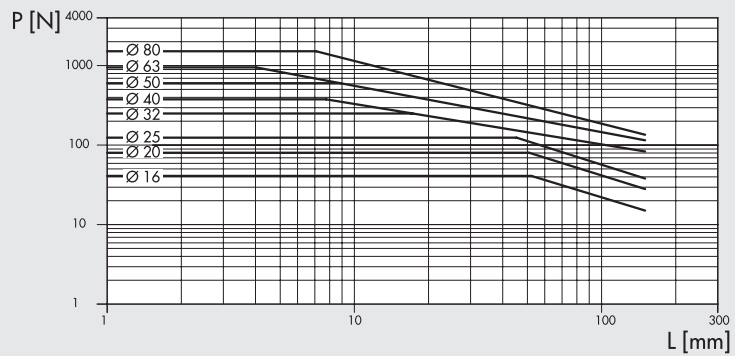

The graph refers to cylinders with a stroke greater than 50 mm with a ball recirculation guide.

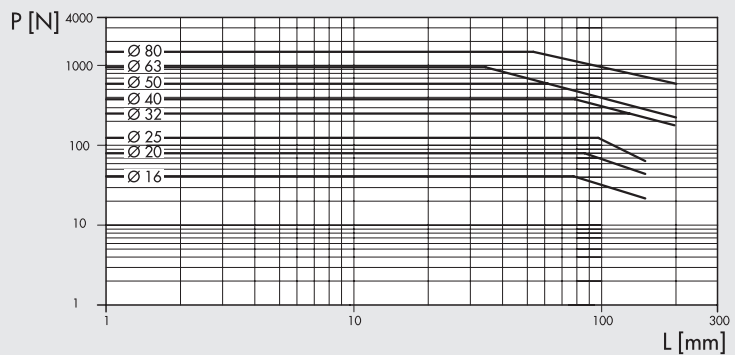

The graph refers to cylinders with a bushing guide.

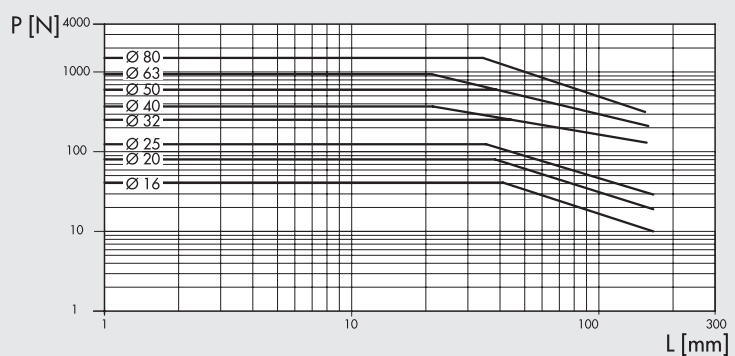

DIMENSIONS SILENCED VERSION Ø 16 - 63

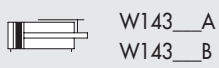
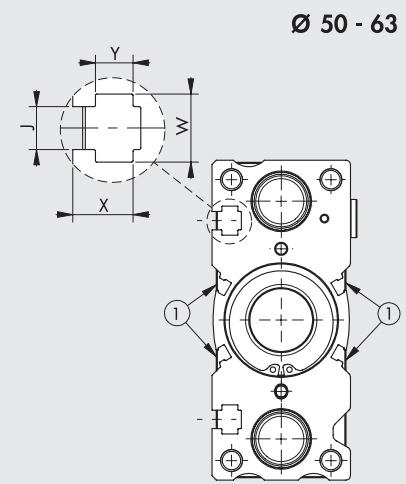
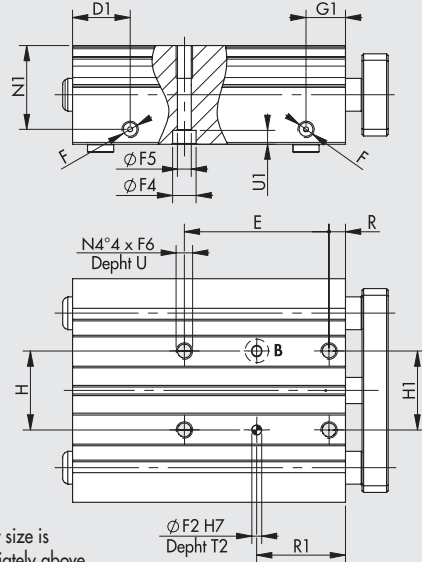
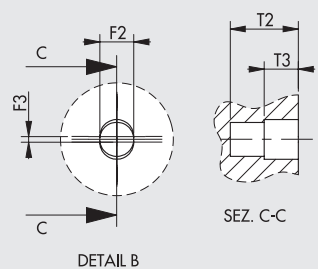
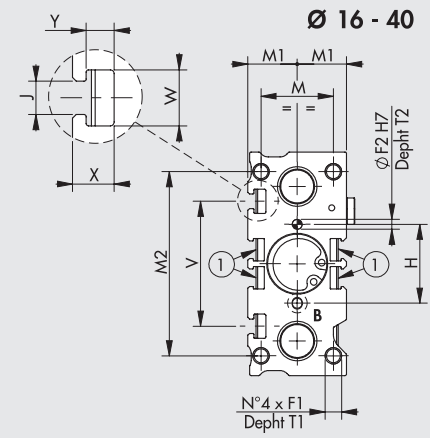
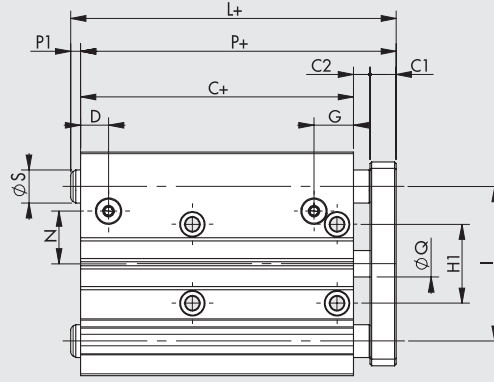
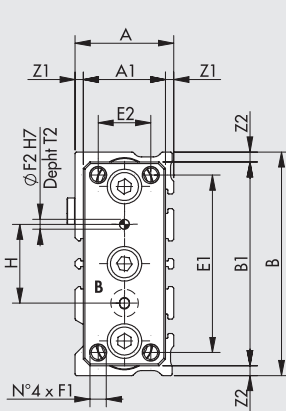

+ = ADD THE STROKE
1 = SENSOR SLOT

♦ For cylinders with non-standard strokes, the correct size is that of the cylinder with the standard stroke immediately above.

Ø	A	A1	B	B1	C♦	C1	C2	D	D1	E1	E2	F	F1	F2 ^{H7}	F3	F4	F5	F6	G	G1	H ^{+0.025}	H1	I	J	M	M1
16	30	25	68	62	33	8	5	8.5	17.5	54	16	M5	M5	3	0.5	7.2	4.2	M5	12	12	24	24	47	4.4	22	15
20	36	30	83	81	37	10	6	9.5	24.5	70	18	G1/8	M5	3	0.5	8.8	5.2	M6	10.5	10.5	28	28	54	5.4	24	18
25	42	38	101	91	37.5	10	6	10	24.5	78	26	G1/8	M6	4	0.5	8.8	5.2	M6	10	10	34	34	68	5.4	30	21
32	48	44	112	110	37.5	12	10	10	28	96	30	G1/8	M8	4	0.5	10.2	6.8	M8	10.5	10.5	42	42	78	6.5	34	24
40	54	44	120	118	44	12	10	12.5	31	104	30	G1/8	M8	4	0.5	10.2	6.8	M8	12.5	12.5	50	50	86	6.5	40	27
50	64	60	148	146	44	16	12	11	35	130	40	G1/4	M10	5	1	14	8.6	M10	14	12	66	66	110	8.5	46	32
63	78	70	162	158	49	16	12	13.5	35	130	50	G1/4	M10	5	1	14	8.6	M10	16.5	16.5	80	80	124	11	58	39

Ø	M2	N	N1	P♦	Q	R	S	T1	T2	T3	U	U1	V	W	X	Y	Z1	Z2
16	56	16	25.5	46	8	5	10	10	6	3	10	4.2	38	7.4	5.5	3.7	2.5	3
20	72	25	29.5	53	10	17	12	12	6	3	12	5.2	44	8.4	7	4.5	3	1
25	82	25.5	36	53.5	12	17	16	12	6	3	12	5.2	50	8.4	7	4.5	2	5
32	98	35.5	41	59.5	16	21	20	16	6	3	16	6.2	63	10.5	7.5	5.5	2	1
40	106	36	46.5	66	16	22	20	16	6	3	16	6.2	72	10.5	7.5	5.5	5	1
50	130	47	54	72	20	24	25	21	8	4	20	9	92	13.5	12	7.5	2	1
63	142	55	67	77	20	24	25	21	8	4	20	9	110	17.8	17	10	4	2

Ø	E Strokes					R1 Strokes					L♦ Strokes			P1 Strokes		
	10-30	40-100	125-200	250-300	350-400	10-30	40-100	125-200	250-300	350-400	10-50	75-200	250-400	10-50	75-200	250-400
16	24	44	110	200	-	17	27	60	105	-	49	79	109	3	33	63
20	24	44	120	200	300	29	39	77	117	167	58	88	118	5	35	65
25	24	44	120	200	300	29	39	77	117	167	70.5	103	118	17	49.5	64.5
32	24	48	124	200	300	33	45	83	121	171	88	88	138	28.5	28.5	78.5
40	24	48	124	200	300	34	46	84	122	172	88	88	138	22	22	72
50	24	48	124	200	300	36	48	86	124	174	79	112	160	7	40	88
63	28	52	128	200	300	38	50	88	124	174	78.5	111.5	159.5	1.5	34.5	82.5

DIMENSIONS SILENCED VERSION Ø 80

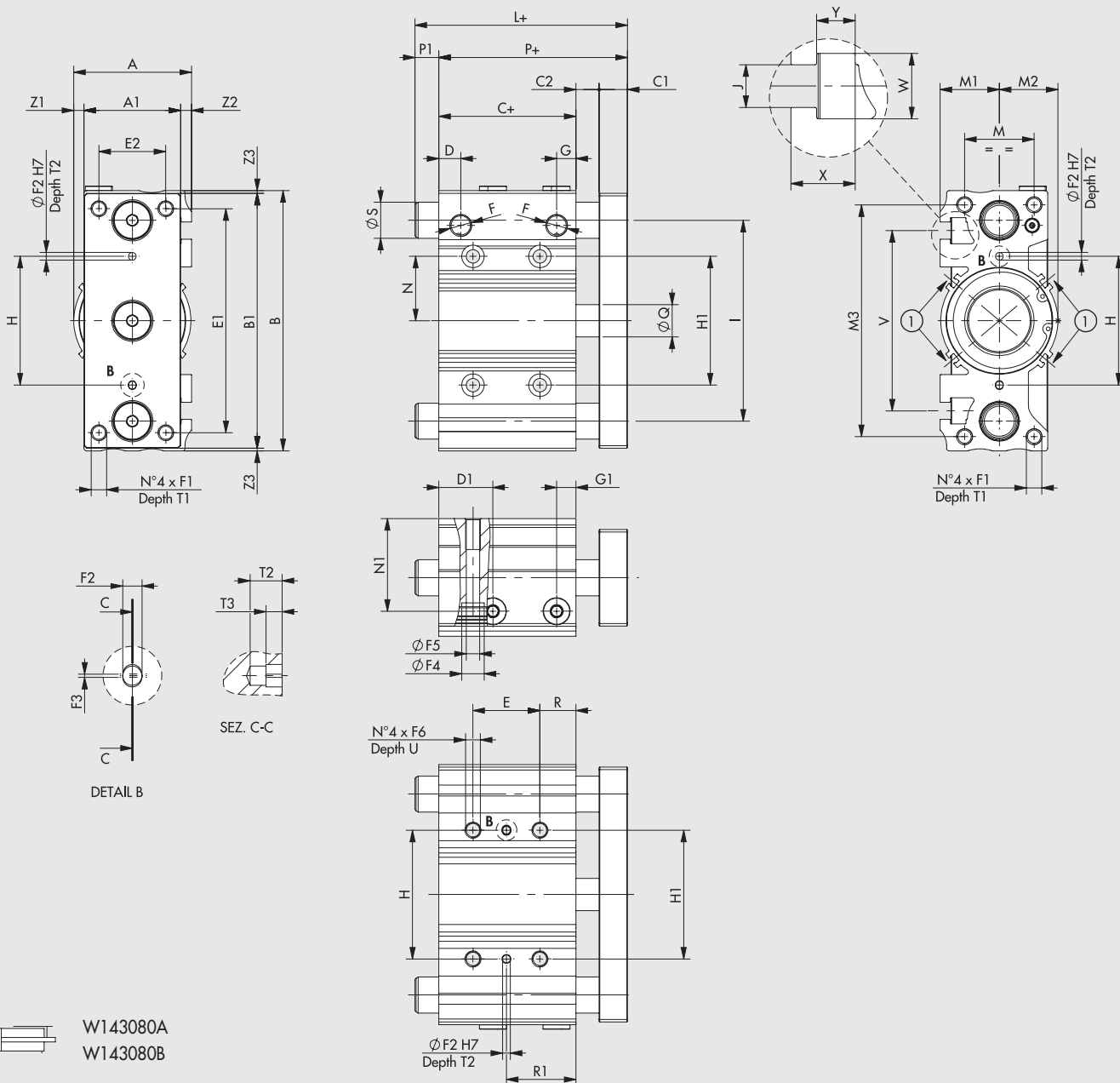

W143080A
W143080B

+ = ADD THE STROKE
1 = SENSOR SLOT

◆ For cylinders with non-standard strokes, the correct size is that of the cylinder with the standard stroke immediately above.

Ø	A	A1	B	B1	C◆	C1	C2	D	D1	E1	E2	F	F1	F2 ^{H7}	F3	F4	F5	F6	G	G1	H ^{+0.025}	H1	I	J	M	M1
80	91.5	75	202	198	56.5	22	18	17	42	174	52	G3/8	M12	6	1	17.5	10.5	M12	15	15	100	100	156	13.3	54	46

Ø	M2	M3	N	N1	P◆	Q	R	S	T1	T2	T3	U	V	W	X	Y	Z1	Z2	Z3
80	45.5	180	50	72	96.5	25	28	28	25	10	5	24	140	20.3	20	12	8	8.5	2

Ø	E Strokes					R1 Strokes					L◆ Strokes			P1 Strokes		
	25	50-100	125-200	250-300	350-400	25	50-100	125-200	250-300	350-400	25-50	75-200	250-400	25-50	75-200	250-400
80	28	52	128	200	300	42	54	92	128	178	115	163	194	18.5	66.5	97.5

DIMENSIONS WITH PNEUMATIC CUSHIONING VERSION Ø 16 - 63

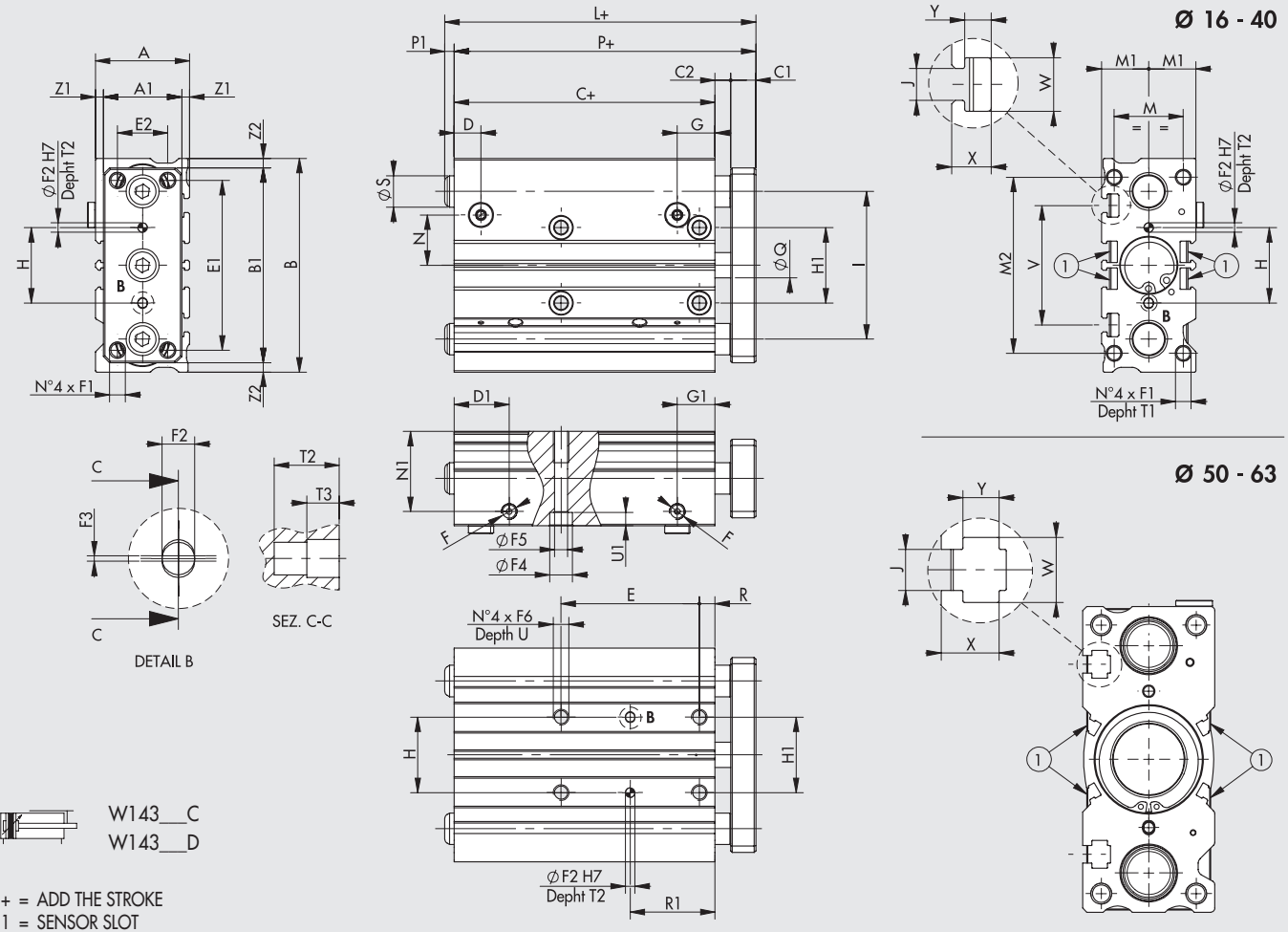

ACTUATORS

COMPACT GUIDED CYLINDER SERIES MULTIFIX

Ø	A	A1	B	B1	C	C1	C2	D	D1	E1	E2	F	F1	F2 ^{H7}	F3	F4	F5	F6	G	G1	H ^{+0.025}	H1	I	J	M	M1
16	30	25	68	62	58	8	5	8.5	17.5	54	16	M5	M5	3	0.5	7.2	4.2	M5	12	12	24	24	47	4.4	22	15
20	36	30	83	81	62	10	6	9	24.5	70	18	G1/8	M5	3	0.5	8.8	5.2	M6	11.5	11.5	28	28	54	5.4	24	18
25	42	38	101	91	62.5	10	6	9.5	24.5	78	26	G1/8	M6	4	0.5	8.8	5.2	M6	10	10	34	34	68	5.4	30	21
32	48	44	112	110	62.5	12	10	9	28	96	30	G1/8	M8	4	0.5	10.2	6.8	M8	9	9	42	42	78	6.5	34	24
40	54	44	120	118	69	12	10	10	31	104	30	G1/8	M8	4	0.5	10.2	6.8	M8	10	10	50	50	86	6.5	40	27
50	64	60	148	146	69	16	12	11	35	130	40	G1/4	M10	5	1	14	8.6	M10	14	12	66	66	110	8.5	46	32
63	78	70	162	158	74	16	12	13.5	35	130	50	G1/4	M10	5	1	14	8.6	M10	16.5	16.5	80	80	124	11	58	39

Ø	M2	N	N1	P	Q	R	S	T1	T2	T3	U	U1	V	W	X	Y	Z1	Z2
16	56	16	25.5	71	8	5	10	10	6	3	10	4.2	38	7.4	5.5	3.7	2.5	3
20	72	25	29.5	78	10	17	12	12	6	3	12	5.2	44	8.4	7	4.5	3	1
25	82	25.5	36	78.5	12	17	16	12	6	3	12	5.2	50	8.4	7	4.5	2	5
32	98	35.5	41	84.5	16	21	20	16	6	3	16	6.2	63	10.5	7.5	5.5	2	1
40	106	36	46.5	91	16	22	20	16	6	3	16	6.2	72	10.5	7.5	5.5	5	1
50	130	47	54	97	20	24	25	21	8	4	20	9	92	13.5	12	7.5	2	1
63	142	55	67	102	20	24	25	21	8	4	20	9	110	17.8	17	10	4	2

Ø	E Strokes				R1 Strokes				L Strokes			P1 Strokes		
	25-75	100-175	200-250	300-400	25-75	100-175	200-250	300-400	25-50	75-200	250-400	25-50	75-200	250-400
16	44	110	200	-	27	60	105	-	71	79	109	0	8	38
20	44	120	200	300	39	77	117	167	78	88	118	0	10	40
25	44	120	200	300	39	77	117	167	78.5	103	118	0	24.5	39.5
32	48	124	200	300	45	83	121	171	88	88	138	3.5	3.5	53.5
40	48	124	200	300	46	84	122	172	91	91	138	0	0	47
50	48	124	200	300	48	86	124	174	97	112	160	0	15	63
63	52	128	200	300	50	88	124	174	102	111.5	159.5	0	9.5	57.5

DIMENSIONS WITH PNEUMATIC CUSHIONING VERSION Ø 80

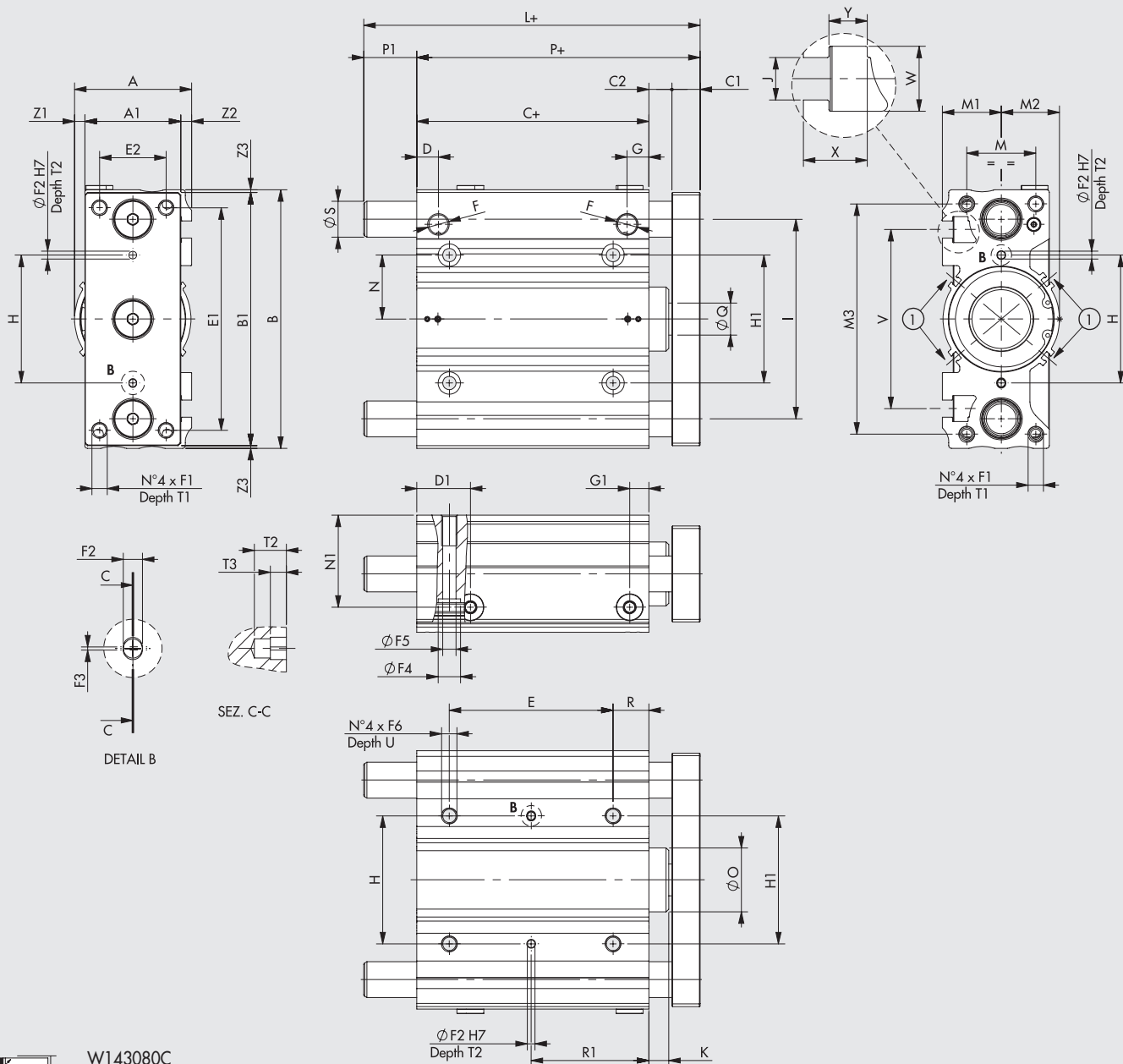

W143080C
W143080D

+ = ADD THE STROKE
1 = SENSOR SLOT

Ø	A	A1	B	B1	C	C1	C2	D	D1	E1	E2	F	F1	F2 ^{H7}	F3	F4	F5	F6	G	G1	H ^{0.025}	H1	I	J	K	M
80	91.5	75	202	198	81.5	22	18	17	42	174	52	G3/8	M12	6	1	17.5	10.5	M12	17	15	100	100	156	13.3	15.5	54

Ø	M1	M2	M3	N	N1	O	P	Q	R	S	T1	T2	T3	U	V	W	X	Y	Z1	Z2	Z3
80	46	45.5	180	50	72	50	121.5	25	28	28	25	10	5	24	140	20.3	20	12	8	8.5	2

Ø	E Strokes				R1 Strokes				L Strokes			P1 Strokes		
	25-75	100-175	200-300	350-400	25-75	100-200	250-300	350-400	25-50	75-200	250-400	25-50	75-200	250-400
80	52	128	200	300	54	92	128	150	121.5	163	194	0	41.5	72.5

KEY TO CODES



W 1 4 3	0 2 0	D	0 7 5
TYPE	DIAMETER	VERSION	STROKE
Compact guided cylinder	016 16 020 20 025 25 032 32 040 40 050 50 063 63 080 80	A Bronze bushings, silenced B Ball recirculating bearings, silenced C Bronze bushings with pneumatic cushioning D Ball recirculating bearings with pneumatic cushioning	SILENCED VERSION ◆ Ø 16: 10, 20, 30, 40, 50, 75, 100, 125, 150, 175, 200, 250 Ø 20 to 25: 20, 30, 40, 50, 75, 100, 125, 150, 175, 200, 250, 300, 350, 400 Ø 32 to 80: 25, 50, 75, 100, 125, 150, 175, 200, 250, 300, 350, 400 WITH PNEUMATIC CUSHIONING VERSION Ø 16: 25, 50, 75, 100, 125, 150, 175, 200, 250 Ø 20 to 80: 25, 50, 75, 100, 125, 150, 175, 200, 250, 300, 350, 400 ◆ Other strokes on request but with the same cylinder dimensions as the standard stroke immediately above.

ACCESSORIES

RETRACTABLE SENSOR

SENSOR, SQUARE TYPE 

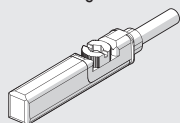
Latest generation,
secure fixing

SENSOR, OVAL TYPE 

Traditional

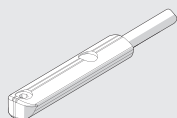

For codes and technical data, see **chapter A6**.

NOTES