

PUSH-IN FITTINGS FOR USE IN THE FOOD INDUSTRY

SERIES F-E PLUS FITTINGS

With the fittings in the F-E Plus series, you can extend all the advantages of the Metal Work push-in fittings to the food industry as well.

As is known, a Metal Work push-in fitting can be reused thousands of times without affecting the pneumatic and mechanical tightness. The refined profile of the clamping spring retains the pipe without cutting or deforming it. The characteristic element of the F-E Plus fittings is the use of materials and lubricants that are chosen for the specific field of application.

All brass component parts undergo a clean-lead process, which consists of removing lead from the surface layer of the fitting; the gaskets are made of special FDA-approved Viton®.

Engineering plastic materials are suitable for use at high temperatures and in contact with water.

The fitting can be used up to 150°C depending on the choice of materials, which makes it ideal for use in applications at high temperatures.

The threads are cylindrical and under-head O-rings provide a pneumatic seal. This avoids the need for sealants (e.g. Teflon®), which could release solid fragments during screwing and unscrewing that would contaminate the environment or the fluid. Our fittings can be screwed and unscrewed any number of times and still remain clean and pneumatically sealed.

In addition to the standard range available, many other configurations can be created on specific request.



TECHNICAL DATA

Threaded port		Metric: M5
		G (BSP)*: 1/8 - 1/4 - 3/8 - 1/2
Diameter		Ø 4 - Ø 6 - Ø 8 - Ø 10
Temperature range	°C	- 20 to + 150
	°F	- 4 to 302
Pressure range	bar	- 0.99 to +16
	MPa	- 0.099 to +1.6
Recommended pipe		Rilsan PA 11 - Nylon 6 - Polyamide 12 - Polypropylene
		PTFE for temperatures over 60°C
Fluid		Vacuum - Compressed air

* Metric cylindrical threads according to ISO 262

Cylindrical threads according to ISO 228-1, identified with a letter G. They also correspond to BSP or more precisely to BSPP designation (P stands for Parallel).

Conical threads according to ISO 7-1, identified by a letter R. They also correspond to BSP or more precisely to BSPT designation (T stands for Tapered).

COMPONENTS

- ① Release bushing: PPSU
- ② Locking bushing: PPSU
- ③ Body: unleaded brass treated with environmentally-friendly intermetallic alloy
- ④ Clamping spring: stainless steel
- ⑤ Spring supporting ring: PPSU
- ⑥ Seal: FDA-approved Viton®

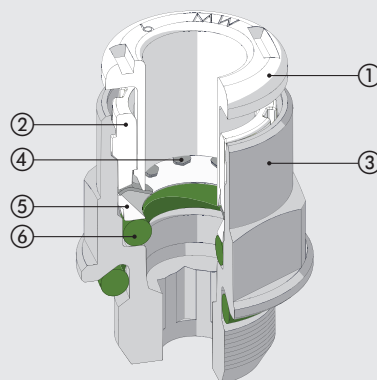

ADVANTAGES / CERTIFICATIONS

ADVANTAGES

Under-head O-ring

Can be screwed and unscrewed any number of times; no fragments of Teflon® or sealant will contaminate the fluid.

Corrosion resistance

The intermetallic alloy deposited on the surface and Viton® are compatible with numerous substances.

CONFORMITY DECLARATIONS

- Regulation 1935/04 EU.*
- Regulation 2023/06 EU.



* Release tests performed at 50°C for 30 minutes.

INSTALLING THE PIPE

Compressed air pipes must be used in compliance with some basic criteria in order to ensure long life and proper operation of the fitting:

- check that the conditions for the installation and use (e.g. temperature and fluid used) comply with the characteristics stated by the pipe manufacturer;
- check the pipe size; oversized pipes could not fit properly, undersized ones could not ensure pipe retention and air tightness.

The cut should be as accurate as possible at a right angle with the pipe axis.

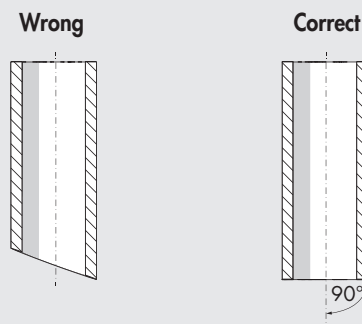

- the bending radius of the pipe installed must be as wide as possible. The fittings have been designed to ensure axial seal of the pipe; excessive curvature could considerably shorten the life of the pipe.
- the pipe must not be subjected to excessive axial stress and it must be of the right length for snugly fitting (not too long or too short).
- correct insertion of the pipe into the fitting is essential for air tightness and pipe retention. Make sure that the pipe is pushed right into the seat.
- check that the pipe does not encounter any obstacles or blockages along its way, which could cause tensile stress of the pipe in the fitting.

STRAIGHT, CYLINDRICAL, MALE R1 F-E PLUS

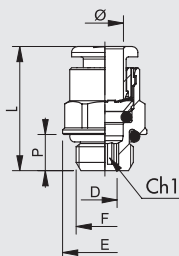

Code	Ref.	Ø	F	Ch	Ch1	P	L	D	E
2FP0101	R1 F-E-P	4	M5	Ø9	2.5	4	20.3	2.6	9
2FP0102	R1 F-E-P	4	1/8	10	3	6	18	3.1	14
2FP0103	R1 F-E-P	4	1/4	10	3	8	19.8	3.1	18
2FP0100	R1 F-E-P	6	M5	Ø11	2.5	4	21.9	2.6	11
2FP0107	R1 F-E-P	6	1/8	12	4	6	21.6	4.1	14
2FP0108	R1 F-E-P	6	1/4	12	4	8	20.3	4.1	18
2FP0109	R1 F-E-P	8	1/8	13	5	6	25.4	5.2	14
2FP0110	R1 F-E-P	8	1/4	14	6	8	24.4	6.2	18
2FP0111	R1 F-E-P	8	3/8	14	6	9	22.8	6.2	22
2FP0112	R1 F-E-P	10	1/4	16	7	8	29.2	7.2	18
2FP0113	R1 F-E-P	10	3/8	16	8	9	26.5	8.2	22
2FP0122	R1 F-E-P	10	1/2	16	8	11	29.8	8.2	26

STRAIGHT, CONICAL, MALE R1C F-E PLUS

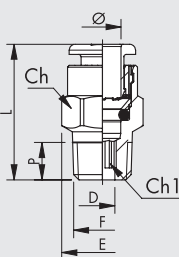

Code	Ref.	Ø	F	Ch	Ch1	P	L	D	E
2FP1C02	R1/C F-E-P	4	1/8	10	3	6.2	18.5	3.1	11.3
2FP1C07	R1/C F-E-P	6	1/8	12	4	6.2	22.5	4.1	13.5
2FP1C08	R1/C F-E-P	6	1/4	12	4	8.5	22.3	4.1	13.2
2FP1C09	R1/C F-E-P	8	1/8	13	6	6.2	26	6.2	14.3
2FP1C10	R1/C F-E-P	8	1/4	14	6	8.5	25.5	6.2	15.8
2FP1C11	R1/C F-E-P	8	3/8	14	6	9	24.9	6.2	16.6
2FP1C13	R1/C F-E-P	10	1/4	16	7	8.5	28.9	7.2	17.7
2FP1C14	R1/C F-E-P	10	3/8	16	8	9	26	8.2	17.7

STRAIGHT, FEMALE R2 F-E PLUS

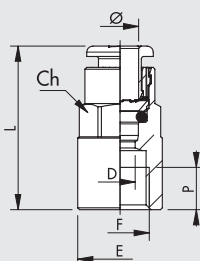

Code	Ref.	Ø	F	Ch	P	L	D	E
2FP0201	R2 F-E-P	4	1/8	10	7	26.2	3	14
2FP0205	R2 F-E-P	6	1/8	12	7	27.1	5	14
2FP0206	R2 F-E-P	6	1/4	12	8	29.3	5	17
2FP0207	R2 F-E-P	8	1/8	13	7	28.1	7	14
2FP0208	R2 F-E-P	8	1/4	14	8	30	7	17
2FP0211	R2 F-E-P	10	1/4	16	8	31.8	8	17.7

STRAIGHT, INTERMEDIATE R3 F-E PLUS

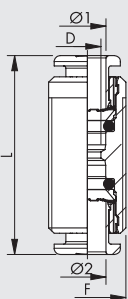

Code	Ref.	Ø1	Ø2	F	L	D
2FP0301	R3 F-E-P	4	4	M11x1	30.6	2.5
2FP0303	R3 F-E-P	6	6	M13x1	33	4.5
2FP0304	R3 F-E-P	8	8	M15x1	35.7	6.5
2FP0305	R3 F-E-P	10	10	M17x1	39.2	8

ELBOW, INTERMEDIATE R4 F-E PLUS

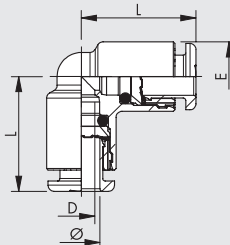

Code	Ref.	Ø	L	D	E
2FP0401	R4 F-E-P	4	16.7	2.5	9.5
2FP0403	R4 F-E-P	6	19	4.5	11.5
2FP0404	R4 F-E-P	8	21.3	6.5	13.5
2FP0405	R4 F-E-P	10	23.3	8	16

TEE, INTERMEDIATE R5 F-E PLUS

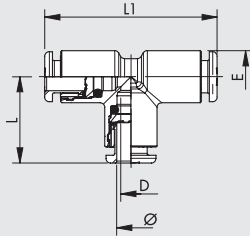

Code	Ref.	Ø	L	L1	D	E
2FP0501	R5 F-E-P	4	16.7	33.4	2.5	9.5
2FP0503	R5 F-E-P	6	19	38	4.5	11.5
2FP0504	R5 F-E-P	8	21.3	42.6	6.5	13.5
2FP0505	R5 F-E-P	10	23.3	46.6	8	16

THREADED ADAPTER R6 F-E

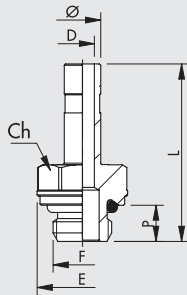

Code	Ref.	Ø	F	Ch	P	L	D	E
2F06001	R6 F-E	4	M5	8	4	25.2	2.5	9
2F06002	R6 F-E	4	1/8	13	6	28.9	2.5	15
2F06003	R6 F-E	4	1/4	14	8	32.4	2.2	18
2F06000	R6 F-E	6	M5	9	4	25.7	2.7	10
2F06007	R6 F-E	6	1/8	13	6	29.4	4	15
2F06008	R6 F-E	6	1/4	14	8	32.9	4	18
2F06009	R6 F-E	8	1/8	13	6	30.6	5.5	15
2F06010	R6 F-E	8	1/4	14	8	34	6	18
2F06011	R6 F-E	8	3/8	17	9	35.4	6	22
2F06012	R6 F-E	10	1/4	14	8	38.2	7.8	18
2F06013	R6 F-E	10	3/8	17	9	38.7	8	22

STRAIGHT, INTERMEDIATE, BULKHEAD UNIONS R10 F-E PLUS

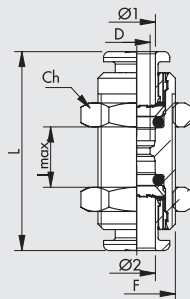

Code	Ref.	Ø1	Ø2	F	Ch	L	D	L _{MAX}
2FP1101	R10 F-E-P	4	4	M11x1	13	30.6	2.5	11
2FP1103	R10 F-E-P	6	6	M13x1	16	33	4.5	12
2FP1104	R10 F-E-P	8	8	M15x1	17	35.7	6.5	13.5
2FP1105	R10 F-E-P	10	10	M17x1	20	39.2	8	17

ROTARY ELBOW, MALE, CYLINDRICAL R31 F-E PLUS

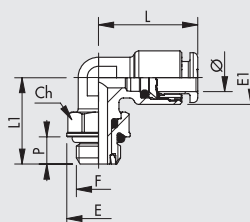

Code	Ref.	Ø	F	Ch	E	E1	L	L1	P
2FP3101	R31 F-E-P	4	M5	9	9.9	9.5	18.6	15.3	4
2FP3102	R31 F-E-P	4	1/8	12	14	9.5	18.6	19.1	6
2FP3103	R31 F-E-P	4	1/4	14	18	9.5	18.6	21.1	8
2FP3107	R31 F-E-P	6	M5	9	9.9	11.8	21.9	15.3	4
2FP3108	R31 F-E-P	6	1/8	12	14	11.8	21.9	19.1	6
2FP3109	R31 F-E-P	6	1/4	14	18	11.8	21.9	21.1	8
2FP3110	R31 F-E-P	8	1/8	12	14	13.5	25.4	19.1	6
2FP3111	R31 F-E-P	8	1/4	14	18	13.5	25.4	21.1	8
2FP3112	R31 F-E-P	8	3/8	17	22	13.8	25.4	27.1	9
2FP3113	R31 F-E-P	10	1/4	14	18	16	27.2	24.8	8
2FP3114	R31 F-E-P	10	3/8	17	22	16	27.2	27.1	9
2FP3115	R31 F-E-P	10	1/2	22	26	16	27.2	30.7	11

ROTARY ELBOW, MALE, CONICAL R31C F-E PLUS

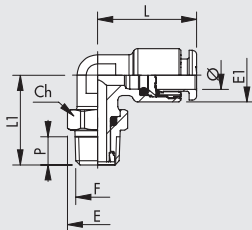

Code	Ref.	Ø	F	Ch	E	E1	L	L1	P
2FP2C02	R31/C F-E-P	4	1/8	12	13.3	9.5	18.6	19.8	6.2
2FP2C03	R31/C F-E-P	4	1/4	14	15.4	9.5	18.6	22.6	8.5
2FP2C08	R31/C F-E-P	6	1/8	12	13.3	11.8	21.9	19.8	6.2
2FP2C09	R31/C F-E-P	6	1/4	14	15.4	11.8	21.9	22.6	8.5
2FP2C10	R31/C F-E-P	8	1/8	12	13.3	13.5	25.4	19.8	6.2
2FP2C11	R31/C F-E-P	8	1/4	14	15.4	13.5	25.4	23.6	8.5
2FP2C12	R31/C F-E-P	8	3/8	17	19.2	13.8	23.6	27.1	9
2FP2C13	R31/C F-E-P	10	1/4	14	15.4	16	27.2	26.3	8.5
2FP2C14	R31/C F-E-P	10	3/8	17	19.2	16	27.2	27.1	9

CENTRAL TEE, MALE, CYLINDRICAL, ROTARY R32 F-E PLUS

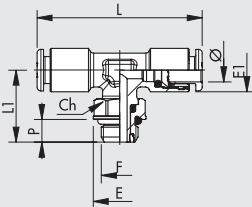

Code	Ref.	Ø	F	Ch	E	E1	L	L1	P
2FP3202	R32 F-E-P	4	1/8	12	14	9.5	37.2	19.1	6
2FP3208	R32 F-E-P	6	1/8	12	14	11.8	43.8	19.1	6
2FP3209	R32 F-E-P	6	1/4	14	18	11.8	43.8	21.1	8
2FP3210	R32 F-E-P	8	1/8	12	14	13.5	50.8	19.1	6
2FP3211	R32 F-E-P	8	1/4	14	18	13.5	50.8	21.1	8
2FP3212	R32 F-E-P	8	3/8	17	22	13.8	47.2	27.1	9
2FP3213	R32 F-E-P	10	1/4	14	18	16	44.4	21.8	8
2FP3214	R32 F-E-P	10	3/8	17	22	16	44.4	27.1	9

LATERAL TEE, MALE, CYLINDRICAL, ROTARY R38 F-E PLUS

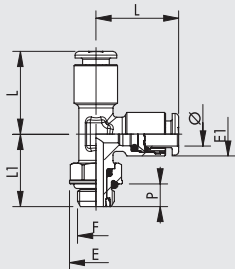

Code	Ref.	Ø	F	Ch	E	E1	L	L1	P
2FP3802	R38 F-E-P	4	1/8	12	14	9.5	18.6	19.1	6
2FP3808	R38 F-E-P	6	1/8	12	14	11.5	21.9	19.1	6
2FP3809	R38 F-E-P	6	1/4	14	18	11.5	21.9	21.1	8
2FP3810	R38 F-E-P	8	1/8	12	14	13.5	25.4	19.1	6
2FP3811	R38 F-E-P	8	1/4	14	18	13.5	25.4	22.4	8
2FP3813	R38 F-E-P	10	1/4	14	18	16	27.2	21.8	8
2FP3814	R38 F-E-P	10	3/8	17	22	16	27.2	27.1	9

ELBOW, MALE, CONICAL R39C F-E PLUS

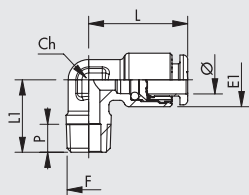

Code	Ref.	Ø	F	Ch	E1	L	L1	P
2FP4C02	R39/C F-E-P	4	1/8	10	9.5	18.6	16	6.2
2FP4C08	R39/C F-E-P	6	1/8	10	11.8	21.9	16	6.2
2FP4C09	R39/C F-E-P	6	1/4	10	11.8	21.9	18.5	8.5
2FP4C10	R39/C F-E-P	8	1/8	10	13.5	24.5	16	6.2
2FP4C11	R39/C F-E-P	8	1/4	10	13.5	25.4	18.5	8.5
2FP4C12	R39/C F-E-P	8	3/8	14	13.8	25.4	22.5	9
2FP4C13	R39/C F-E-P	10	1/4	14	16	27.2	22	8.5