

# ROUND CYLINDER SERIES RNDC

Clean profile cylinders available in different versions:

- configuration with or without magnet
- single- and double-acting - single or through-rod
- pneumatic cushioning on request
- range of gaskets available in NBR, POLYURETHANE and FKM/FPM (for high temperatures)



TECHNICAL DATA			Ø32	Ø40	Ø50
Max operating pressure		bar		10	
		MPa		1	
		psi		145	
Temperature range	POLYURETHANE	°C		-25 to +80	
		°C		-10 to +80	
	FKM/FPM	°C		-10 to +150 (non-magnetic cylinders)	
		°C		-35 to +80	
Design			Screwed heads		
Fluid			Unlubricated air. Lubrication, if used, must be continuous.		
Standard strokes †	Single-acting	mm		1 to 250	
	Double-acting	mm		1 to 500	
Versions			Double-acting, Double-acting through-rod, Double-acting cushioned, Double-acting through-rod cushioned, Single-acting, Single-acting through-rod, No stick-slip.		
Sensor magnet			Available magnetic and non-magnetic versions.		
Inrush pressure		bar		0.4	0.3
Forces generated at 6 bar thrust/retraction			See cylinder "General technical data" at the beginning of the chapter		
Weights			See cylinder "General technical data" at the beginning of the chapter		
Notes			<b>For speeds lower than 0.2 m/s to prevent surging, use the version No stick-slip and non-lubricated air.</b> † Maximum recommended strokes. Higher values can create operating problems		

## COMPONENTS

- ① PISTON ROD: C45 steel or stainless steel, thick chromed
- ② PISTON ROD GASKET: polyurethane, NBR or FKM/FPM
- ③ GUIDE BUSHING: steel strip with bronze and PTFE insert
- ④ BARREL: drawn anodized aluminium alloy
- ⑤ HALF-PISTON: self-lubricating technopolymer with integrated cushioning olives
- ⑥ MAGNET: plastoferrite
- ⑦ PISTON GASKET: polyurethane, NBR or FKM/FPM
- ⑧ HEAD: anodized aluminium alloy
- ⑨ HEAD: anodized aluminium alloy

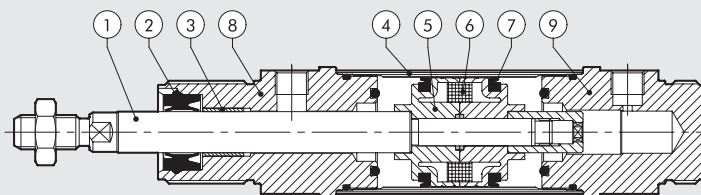

**DIMENSIONS OF STANDARD VERSIONS**

+ = ADD STROKE

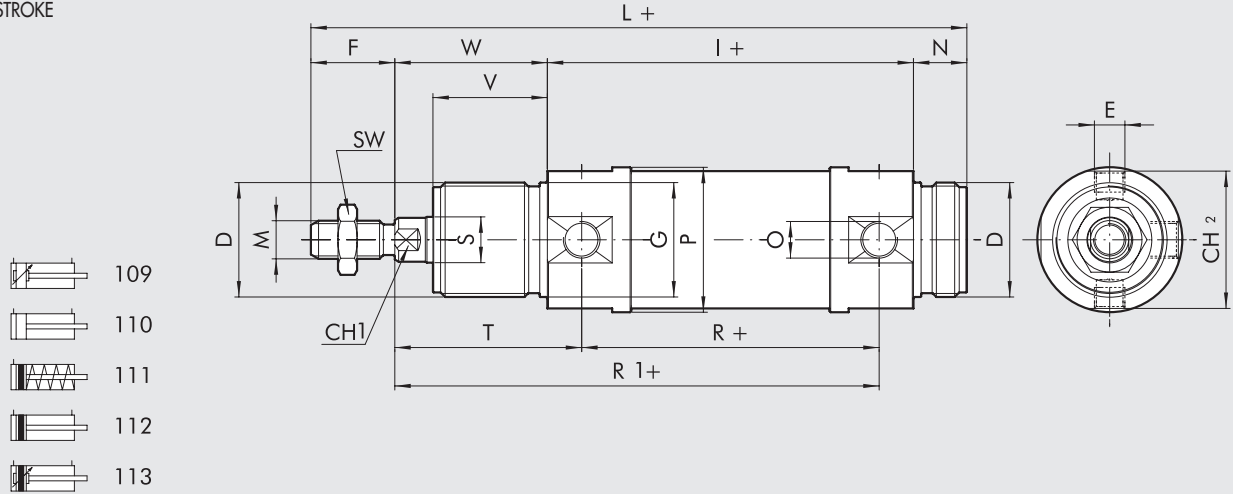

- 109
- 110
- 111
- 112
- 113

**DIMENSIONS OF THROUGH-ROD VERSIONS**

+ = ADD STROKE  
++ = ADD TWICE THE STROKE

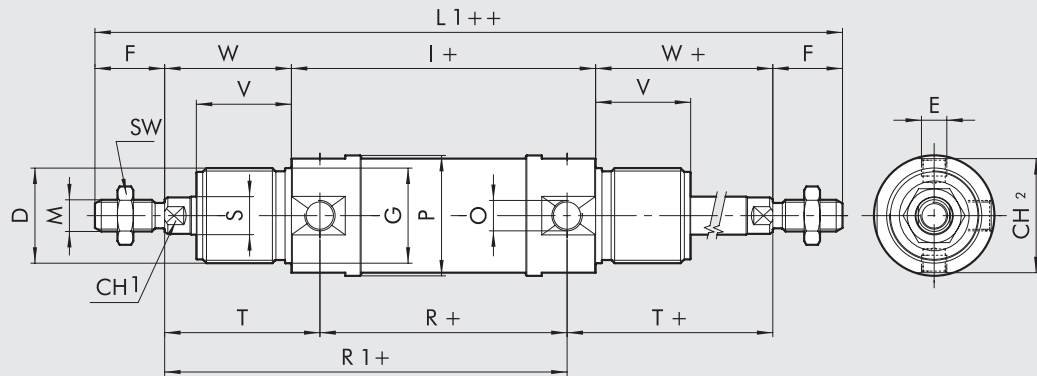

- 104
- 114
- 115

**DIMENSIONS OF STANDARD DOUBLE-ACTING AND THROUGH-ROD**

Ø D	E	F	Ø G	CH1	I	L	M	N	O	Ø P	R	Ø S	SW	T	CH2	V	W	L1	
32	M30x1.5	M8x1	22	30	10	96	172	M10x1.25	14	G1/8	38	78	12	17	49	36	30	40	220
40	M38x1.5	M10x1	24	38	13	113	198	M12x1.25	16	G1/4	46	89	16	19	57	43	35	45	251
50	M45x1.5	M12x1.5	32	45	17	120	220	M16x1.5	18	G1/4	57	96	20	24	62	54	38	50	284

**DIMENSIONS OF STANDARD SINGLE-ACTING AND THROUGH-ROD**

Lower limit	Stroke	Upper limit	I			L			R1			L1		
			Ø 32	Ø 40	Ø 50	Ø 32	Ø 40	Ø 50	Ø 32	Ø 40	Ø 50	Ø 32	Ø 40	Ø 50
0	< C ≤	50	96	113	120	172	198	220	127	146	158	220	251	284
50	< C ≤	100	125	145.5	155.5	201	230.5	255.5	156	178.5	193.5	249	283.5	319.5
100	< C ≤	150	154	178	191	230	263	291	185	211	229	278	316	355
150	< C ≤	200	183	210.5	226.5	259	295.5	326.5	214	243.5	264.5	307	348.5	390.5
200	< C ≤	250	212	243	262	288	328	362	243	276	300	336	381	426

For all the other values, see previous table, except for T and R which are both replaced by R1



## ACCESSORIES FOR ROUND CYLINDER: FIXINGS

### FOOT MODEL AC

+ = ADD STROKE

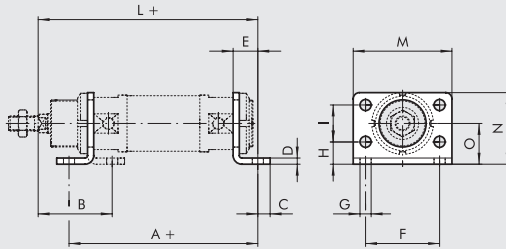

Code	Ø	A	B	C	D	E	F	G	H	I	L	M	N	O	Weight [g]
W0950320002	32	124	50	7	4	14	52	7	14	28	150	66	49	28	104
W0950400002	40	153	60	10	5	20	60	9	18	30	178	80	58	33	190
W0950500002	50	160	64	10	6	20	70	9	20	40	190	90	70	40	296

Note: Individually packed

### COUNTER-HINGE MODEL BC

+ = ADD STROKE

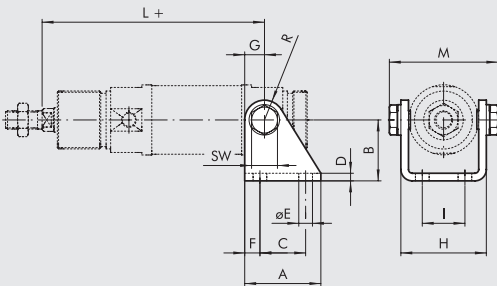

Code	Ø	A	B	C	D	E	F	G	H	I	L	M	R	SW	Weight [g]
W0950320005	32	40	35	24	4	7	8	12	46.1	20	127	60	12	13	152
W0950400005	40	50	40	30	5	9	10	13	57.5	28	146	74	13	17	262
W0950500005	50	54	45	34	6	9	10	14	69.1	36	158	89	14	19	401

Note: Supplied with 2 screws

### HEAD LOCK RING MODEL G

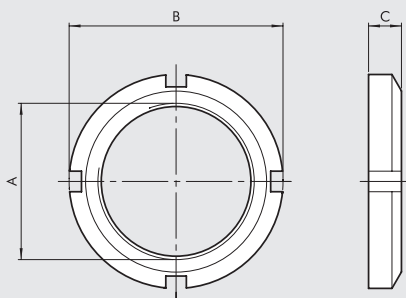

Code	Ø	A	B	C	Weight [g]
W0950320010	32	M30x1.5	45	7	46
W0950400010	40	M38x1.5	50	8	56
W0950500010	50	M45x1.5	58	9	124

Note: Individually packed

### FORK MODEL GK-M

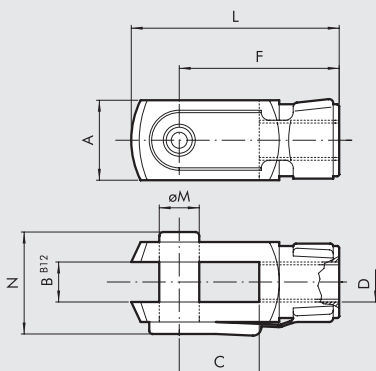

Code	Ø	Ø M	C	B	A	L	F	D	N	Weight [g]
W0950322020	32	10	20	10	20	52	40	M10x1.25	26	92
W0950402020	40	12	24	12	24	62	48	M12x1.25	32	148
W0950502020	50	16	32	16	32	83	64	M16x1.5	40	340

Note: Individually packed

**SPHERICAL JOINT MODEL GA-M**

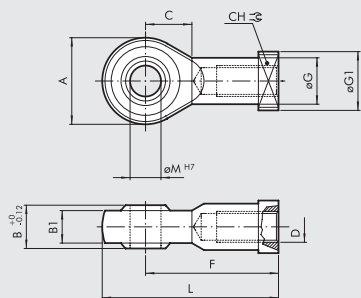

Code	Ø	øM	C	B1	B	A	L	F	D	øG	CH	Weight [g]
W0950322025	32	10	15	10.5	14	28	57	43	M10x1.25	15	17	78
W0950402025	40	12	17	12	16	32	66	50	M12x1.25	17.5	19	116
W0950502025	50	16	22	15	21	42	85	64	M16x1.5	22	22	226

Note: Individually packed

**ARTICULATED JOINT MODEL GA-K**

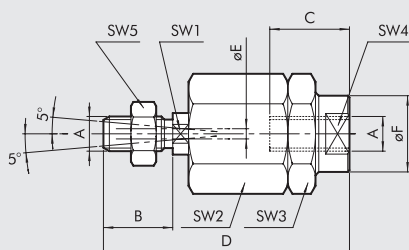

Code	Ø	A	B	C	D	øE	øF	SW1	SW2	SW3	SW4	SW5	Weight [g]
W0950322030	32	M10x1.25	20	20	71	4	22	12	30	30	19	17	216
W0950402030	40	M12x1.25	24	20	75	4	22	12	30	30	19	19	220
W0950502030	50	M16x1.5	32	32	103	4	32	20	41	41	30	24	620

Note: Individually packed

**FLEXIBLE COLLAR - MODEL GA**

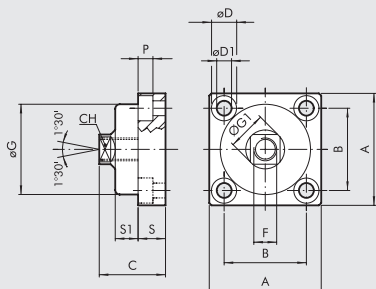

Code	Ø	A	B	C	CH	øD	øD1	F	øG	øG1	P	S	S1	Weight [g]
W0950326021	32	49	36	30	13	11	6.5	M10x1.25	39.5	17	6.5	12	10	172
W0950406021	40	59	42	36	15	14	8.5	M12x1.25	44	19	8.5	15	13.5	286
W0950506021	50	79	58	44	22	17	10.5	M16x1.5	59	26	10.5	20	15	628

Note: Individually packed

**ACCESSORIES FOR ROUND CYLINDER: MAGNETIC SENSORS**

**SENSOR SERIES DSM**

For codes and technical data, see [chapter A6](#).

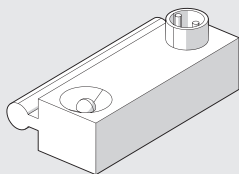

**SENSOR BRACKET**

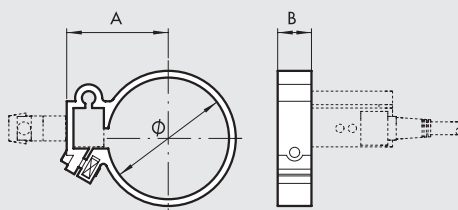

Code	Bore	Model	Ø	A	B
W0950000132	32	Bracket DXF 36 - 32	36	29.5	10
W0950000140	40	Bracket DXF 45 - 40	45	34.5	10
W0950000150	50	Bracket DXF 52 - 50	55	38.5	10



FOR MOUNTING ON THE CYLINDER Ø 50 INSERT THE ALUMINIUM SPACER ① YOU FIND IN THE PACKAGE