

## ROTARY ACTUATOR SERIES R4

Sturdy, compact rotary actuators, suitable for operating industrial valves with ISO 5211 mounting flange and 0-90° swivel angle.

The R4 actuator is the double-rack type, a technology that ensures constant twisting torque during rotation.

The control valve can be fitted directly to the actuator using the NAMUR VDI\VDE-3845 interface or can be controlled remotely using the existing G (BSP) threaded connections.

On the actuator, you can install specific accessories for the detection of limit switch positions (switch box).

Given its specific application, the R4 actuator features high torque and reduced bending moment supported by the shaft.

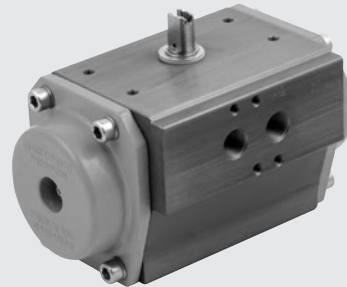

TECHNICAL DATA		Ø 32	Ø 42	Ø 50	Ø 63	Ø 75	Ø 85	Ø 100	Ø 115	Ø 125	Ø 145	
Operating pressure	bar							3 to 8				
	MPa							0.3 to 0.8				
	psi							43 to 116				
Temperature range	°C							-20 to +80				
Fluid								20 µm filtered, unlubricated air				
Rotation angle								90° ±5° (90°±3° for Ø 32)				
Valve fixing interface								According to ISO 5211 and DIN 3337				
Female bottom key								Double square type (star)				
Power interface								According to NAMUR VDI\VDE-3845				
Interface for fixing accessories at the top								According to NAMUR VDI\VDE-3845				
Category ATEX								Ⓜ II 2G Ex h IIC T5 Gb Ⓜ II 2D Ex h IIC T95°C Db				
Assembly position								Any. Upward power takeoff not recommended				
Versions								Single-acting / Double-acting				
Rated torque at 6 bar	Nm	7.6	13.0	18.5	33.0	70.2	106.9	166.4	274.5	361.1	520.2	
Maximum idle rotation	double acting	s	0.5	0.5	0.6	0.7	0.7	0.9	0.9	1.1	1.1	
	single acting	s	-	0.5	0.6	0.9	1	1.3	1.3	1.6	2.1	
Internal volume	double acting	liters	0.07	0.18	0.23	0.45	0.61	0.98	1.8	2.8	3.7	
	single acting	liters	-	0.072	0.092	0.18	0.244	0.392	0.72	1.12	1.48	

### COMPONENTS

- ① BODY: extruded aluminium with hard anodisation
- ② END CAP: pressure die-cast aluminium with polyester powdercoating
- ③ PISTON: anodized pressure die-cast aluminium
- ④ SHAFT WITH PINION: nickel-plated carbon steel
- ⑤ GASKETS: NBR
- ⑥ SLIDING GUIDES: acetal resin
- ⑦ SCREWS AND WASHERS: stainless steel
- ⑧ SEEGER: zinc-plated carbon steel
- ⑨ SPRINGS (for single-acting versions only): carbon steel with polyester powder coating

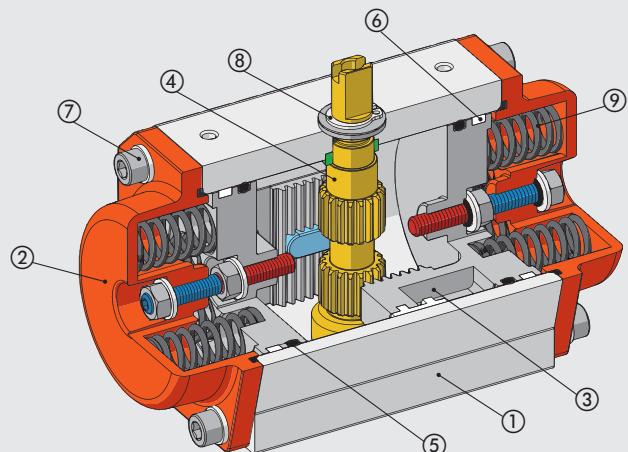

## DIMENSIONING

### CHOOSING THE ACTUATOR

Actuators are chosen by ensuring that the available torque is greater than the torque required by the application, taking into account a safety margin. When used for actuating valves, which is a typical case for this series of actuators, the interface flange and the power takeoff dimension (seat for connection with the valve shaft) must also be verified.

When using ball valves, you need to know the operating torque according to which a minimum safety factor must be considered to ensure correct operation over time, even in the worst operating conditions. As a general rule, the safety factor must be at least 25% but in some applications and, for some valve manufacturers, it is recommended to be up until 50%.

#### • DOUBLE-ACTING VERSION

During rotation, the double-acting actuator provides constant torque at each position and in both directions with the same supply pressure.

##### Powered B4: closing (0°)

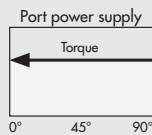
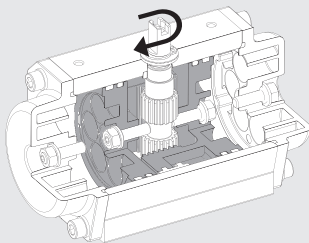

##### Example

Valve operating torque	50 Nm
Safety factor required	25% (12.5 Nm)
Minimum actuator torque required	50 Nm + 12.5 Nm = 62.5 Nm
Actuator supply pressure	6 bar

##### Chosen bore

Chosen bore	75
Based on the supplied torque at 6 bar	70.2 Nm (> 62.5 Nm)
(see table "pair of double-acting actuator")	

##### Actual safety factor

$$(70.2 \text{ Nm} - 50 \text{ Nm}) / 50 \text{ Nm} = 40\%$$

##### Powered A2: opening (90°)

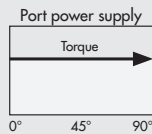
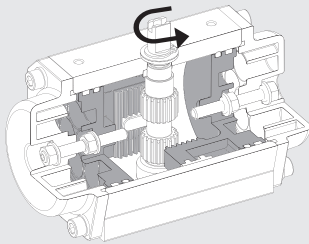

#### • SINGLE-ACTING VERSION

During rotation, the single-acting actuator provides variable torque depending on the angle.

On opening, the maximum torque value is at 0° and then decreases as the compressed springs counteract the movement of the pistons and accumulate energy that is made available when rotation is reversed.

On closing, the maximum torque value is at 90° and then decreases due to the release of the springs.

##### NOT powered: closing (0°)

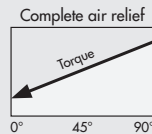
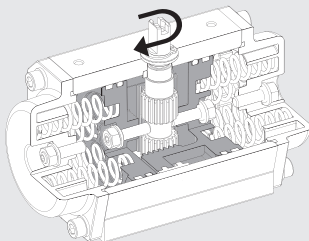

##### Example

Valve operating torque	50 Nm
Safety factor required	30% (15 Nm)
Minimum actuator torque required	50 Nm + 15 Nm = 65 Nm
Actuator supply pressure	6 bar

##### Chosen bore

Chosen bore	115
Based on the supplied torque at 6 bar	106 Nm a 0° (> 65 Nm)
(see table "pair of double-acting actuator")	

##### Actual safety factor

$$(106 \text{ Nm} - 50 \text{ Nm}) / 50 \text{ Nm} = 112\%$$

##### Powered A2: opening (90°)

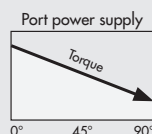
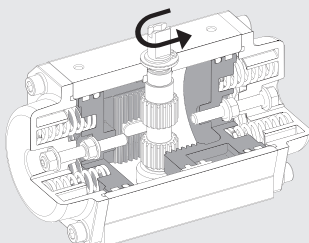

**TORQUE OF DOUBLE-ACTING ACTUATORS [Nm]**

Ø	Supply pressure [bar]							
	1	2	3	4	5	6	7	8
32	-	-	-	5	6.3	7.6	8.8	10
42	-	-	6.5	8.7	10.9	13	15.2	17.3
50	3	6.1	9.2	12.3	15.4	18.5	21.5	24.6
63	5.5	11	16.5	22	27.5	33	38.5	44
75	11.7	23.4	35.1	46.8	58.5	70.2	81.9	93.6
85	17.8	35.6	53.4	71.2	89	106.9	124.7	142.4
100	27.7	55.4	83.2	110.9	138.6	166.4	194.1	221.8
115	45.7	91.5	137.2	183	228.7	274.5	320.2	366
125	60.1	120.3	180.5	240.7	300.9	361.1	421.2	481.4
145	86.7	173.4	260.1	346.8	433.5	520.2	606.9	693.6

**TORQUE OF SINGLE-ACTING ACTUATORS [Nm]**

Ø	Springs per side	Supply pressure [bar]												Non-powered spring torque	
		3		4		5		6		7		8		90°	0°
		0°	90°	0°	90°	0°	90°	0°	90°	0°	90°	0°	90°		
42	3	-	-	-	-	7.1	4.1	9.3	6.3	11.5	8.5	13.7	10.7	6.8	3.8
	4	-	-	-	-	-	-	<b>8.1</b>	<b>4.1</b>	<b>10.2</b>	<b>6.2</b>	<b>12.4</b>	<b>8.4</b>	<b>9</b>	<b>5</b>
50	3	5.7	3.5	8.9	6.6	12	9.6	15.1	12.7	18.1	15.7	21.2	18.8	5.7	3.5
	4	-	-	7.7	4.7	10.8	7.7	13.9	10.8	16.9	13.8	20.2	16.9	7.7	4.7
	5	-	-	-	-	9.6	5.8	12.7	8.9	15.7	11.9	18.8	15	9.6	5.8
	6	-	-	-	-	<b>8.4</b>	<b>3.9</b>	<b>11.5</b>	<b>7</b>	<b>14.5</b>	<b>10</b>	<b>17.6</b>	<b>13.1</b>	<b>11.5</b>	<b>7</b>
63	3	9.4	6.3	14.9	11.7	20.4	17.2	25.9	22.7	31.4	28.2	36.9	33.7	10.2	7.2
	4	-	-	12.3	8.3	17.8	13.8	23.3	19.3	28.8	24.8	34.3	30.3	13.7	9.7
	5	-	-	-	-	15.4	10.4	20.9	15.9	26.4	21.4	31.9	26.9	17.1	12.1
	6	-	-	-	-	<b>13</b>	<b>7</b>	<b>18.5</b>	<b>12.5</b>	<b>24</b>	<b>18</b>	<b>29.5</b>	<b>23.5</b>	<b>20.5</b>	<b>14.5</b>
75	3	22.5	12.6	34.2	24.4	46	36.1	57.7	47.8	69.4	59.5	81.1	71.2	22.5	12.6
	4	-	-	30	16.9	41.8	28.6	53.5	40.3	65.2	52	76.9	63.7	30	16.9
	5	-	-	-	-	37.6	21.1	49.3	32.8	61	44.5	72.7	56.2	37.6	21.1
	6	-	-	-	-	<b>33.4</b>	<b>13.6</b>	<b>45.1</b>	<b>25.3</b>	<b>56.8</b>	<b>37</b>	<b>68.5</b>	<b>48.7</b>	<b>45.1</b>	<b>25.3</b>
85	3	34.5	18.9	52.4	36.7	70.2	54.5	88	72.3	105.8	90.1	123.6	107.9	34.5	18.9
	4	-	-	46.1	25.2	63.9	43	81.7	60.8	99.5	78.6	117.3	96.4	46.1	25.2
	5	-	-	-	-	57.6	31.5	75.4	49.3	93.2	67.1	111	84.9	57.6	31.5
	6	-	-	-	-	<b>51.5</b>	<b>20</b>	<b>69.1</b>	<b>37.8</b>	<b>86.9</b>	<b>55.6</b>	<b>104.7</b>	<b>73.4</b>	<b>69.1</b>	<b>37.8</b>
100	3	53.2	30	80.9	57.7	108.7	85.4	136.4	113.1	164.1	140.8	191.8	168.5	53.2	30
	4	-	-	70.9	40	98.7	67.7	126.4	95.4	154.1	123.1	181.8	150.8	70.9	40
	5	-	-	-	-	88.7	50	116.4	77.7	144.1	105.4	171.8	133.1	88.7	50
	6	-	-	-	-	<b>78.7</b>	<b>32.2</b>	<b>106.4</b>	<b>60</b>	<b>134.1</b>	<b>87.7</b>	<b>161.8</b>	<b>115.4</b>	<b>106.4</b>	<b>60</b>
115	3	84.3	53	130	98.8	175.8	144.5	221.6	190.3	267.3	236	313	281.7	84.3	53
	4	-	-	112.3	70.7	158.1	116.4	203.9	162.2	249.6	207.9	295.3	253.6	112.3	70.7
	5	-	-	-	-	140.4	88.3	186.2	134.1	231.9	179.8	277.6	225.5	140.4	88.3
	6	-	-	-	-	<b>122.7</b>	<b>60.2</b>	<b>168.5</b>	<b>106</b>	<b>214.2</b>	<b>151.7</b>	<b>259.9</b>	<b>197.4</b>	<b>168.5</b>	<b>106</b>
125	3	116.8	63.7	177	123.9	237.3	184.1	297.5	244.2	357.6	304.3	417.7	364.4	116.8	63.7
	4	-	-	155.7	85	216	145.2	276.2	205.3	336.3	265.4	396.4	325.5	155.7	85
	5	-	-	-	-	194.7	106.3	254.9	166.4	315	226.5	375.1	286.6	194.7	106.3
	6	-	-	-	-	<b>173.4</b>	<b>67.4</b>	<b>233.6</b>	<b>127.5</b>	<b>293.7</b>	<b>187.6</b>	<b>353.8</b>	<b>247.7</b>	<b>233.6</b>	<b>127.5</b>
145	3	158	92	245	179	332	265	418	352	505	439	592	526	158	92
	4	-	-	211	123	298	210	384	269	471	383	558	470	224	136
	5	-	-	-	-	264	154	350	240	437	327	524	414	280	170
	6	-	-	-	-	<b>230</b>	<b>98</b>	<b>316</b>	<b>184</b>	<b>403</b>	<b>271</b>	<b>490</b>	<b>358</b>	<b>336</b>	<b>204</b>

**N.B.:** All single-acting actuators come with the maximum quantity of springs that can be fitted to each side, which means that the user can dispense lower torques as required by simply removing unnecessary springs. If the quantity of springs is reduced, carefully check that the residual springs are positioned correctly.

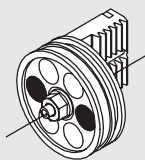

2 springs

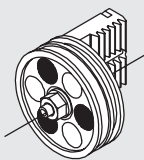

3 springs

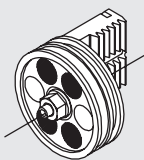

4 springs

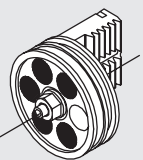

5 springs

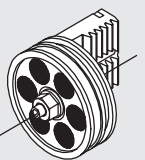

6 springs

EXAMPLES OF APPLICATION

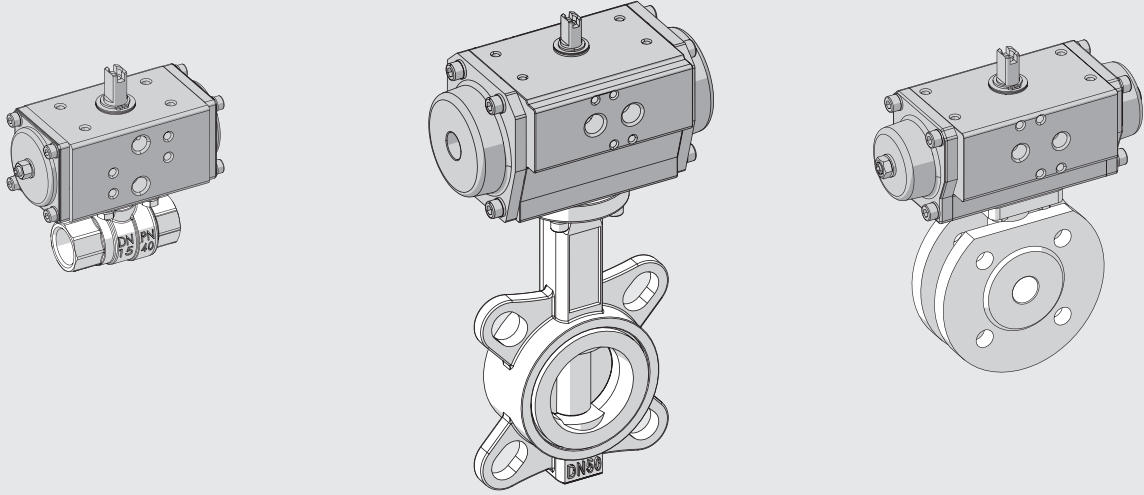

NOTES

Area for technical notes, currently blank.

## DIMENSIONS AND ORDERING CODES

### DIMENSIONS Ø 32 - 42 - 50 - 63

#### Ø 32

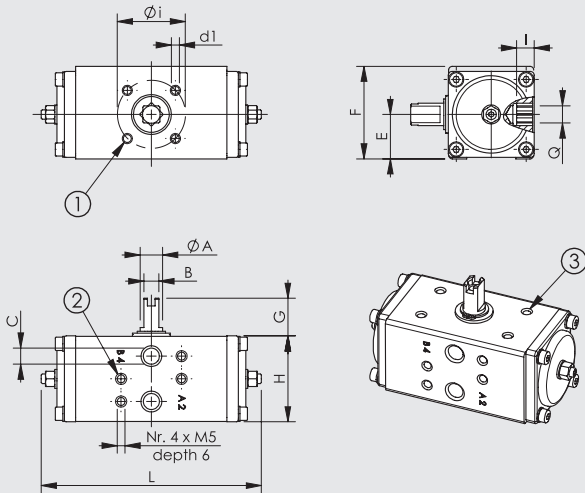

#### Ø 42 - 50 - 63

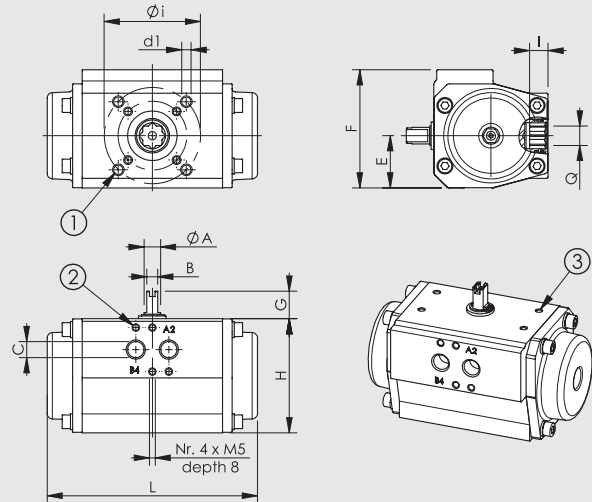

- ① Flange connection according to UNI 5211 and DIN 3337
- ② Supply interface according to NAMUR VDI/VDE-3845
- ③ Holes for fixing accessories according to NAMUR VDI/VDE-3845

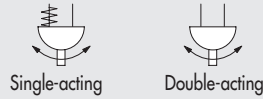

FLANGE ISO 5211	Ø i	d1
F03	36	M5 depth 8
F04	42	M5 depth 8
F05	50	M6 depth 9
F07	70	M8 depth 12
F10	102	M10 depth 15
F12	125	M12 depth 18

Ø	Type	Code	Flange ISO 5211	Q	I	ØA	B	C	G	E	F	H	L	Weight [g]
32	Double-acting	W790A032GQ009DA	F03	9	10	12	8	1/8"	20	23.5	49	45	117	420
		W790B032GQ009DA	F04	9	10	12	8	1/8"	20	23.5	49	45	117	420
42	Double-acting	W79AC042GQ009DA	F03 / F05	9	10	12	8	1/8"	20	27	60.5	57	160	870
		W79AC042GQ011DA	F03 / F05	11	13	12	8	1/8"	20	27	60.5	57	160	870
		W790B042GQ009DA	F04	9	10	12	8	1/8"	20	27	60.5	57	160	870
		W790B042GQ011DA	F04	11	13	12	8	1/8"	20	27	60.5	57	160	870
	Single-acting	W79AC042GQ009SR	F03 / F05	9	10	12	8	1/8"	20	27	60.5	57	160	930
		W79AC042GQ011SR	F03 / F05	11	13	12	8	1/8"	20	27	60.5	57	160	930
		W790B042GQ009SR	F04	9	10	12	8	1/8"	20	27	60.5	57	160	930
		W790B042GQ011SR	F04	11	13	12	8	1/8"	20	27	60.5	57	160	930
50	Double-acting	W79AC050GQ009DA	F03 / F05	9	10	12	8	1/8"	20	33.5	75	67	139	1070
		W79AC050GQ011DA	F03 / F05	11	13	12	8	1/8"	20	33.5	75	67	139	1070
		W790B050GQ009DA	F04	9	10	12	8	1/8"	20	33.5	75	67	139	1070
		W790B050GQ011DA	F04	11	13	12	8	1/8"	20	33.5	75	67	139	1070
	Single-acting	W79AC050GQ009SR	F03 / F05	9	10	12	8	1/8"	20	33.5	75	67	139	1200
		W79AC050GQ011SR	F03 / F05	11	13	12	8	1/8"	20	33.5	75	67	139	1200
		W790B050GQ009SR	F04	9	10	12	8	1/8"	20	33.5	75	67	139	1200
		W790B050GQ011SR	F04	11	13	12	8	1/8"	20	33.5	75	67	139	1200
63	Double-acting	W79AD063GQ009DA	F03 / F05 / F07	9	10	12	8	1/4"	20	38	86	83	152	1600
		W79AD063GQ011DA	F03 / F05 / F07	11	13	12	8	1/4"	20	38	86	83	152	1600
		W79AD063GQ014DA	F03 / F05 / F07	14	16	12	8	1/4"	20	38	86	83	152	1600
		W790B063GQ009DA	F04	9	10	12	8	1/4"	20	38	86	83	152	1600
		W790B063GQ011DA	F04	11	13	12	8	1/4"	20	38	86	83	152	1600
		W790B063GQ014DA	F04	14	16	12	8	1/4"	20	38	86	83	152	1600
	Single-acting	W79AD063GQ009SR	F03 / F05 / F07	9	10	12	8	1/4"	20	38	86	83	152	1800
		W79AD063GQ011SR	F03 / F05 / F07	11	13	12	8	1/4"	20	38	86	83	152	1800
		W79AD063GQ014SR	F03 / F05 / F07	14	16	12	8	1/4"	20	38	86	83	152	1800
		W790B063GQ009SR	F04	9	10	12	8	1/4"	20	38	86	83	152	1800
		W790B063GQ011SR	F04	11	13	12	8	1/4"	20	38	86	83	152	1800
		W790B063GQ014SR	F04	14	16	12	8	1/4"	20	38	86	83	152	1800

DIMENSIONS Ø 75 - 85 - 100 - 115 - 125 - 145

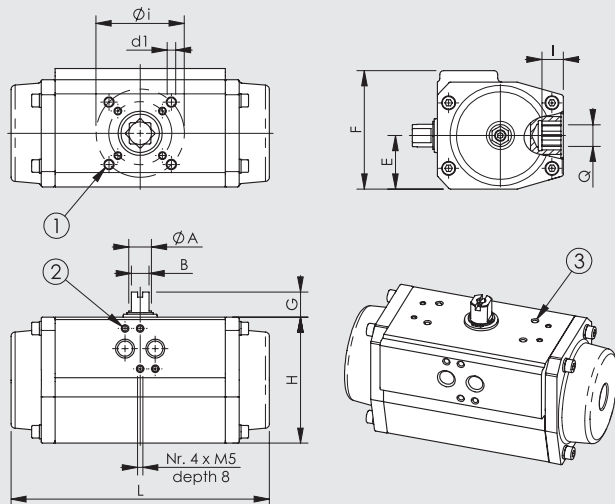

- ① Flange connection according to UNI 5211 and DIN 3337
- ② Supply interface according to NAMUR VDI/VDE-3845
- ③ Holes for fixing accessories according to NAMUR VDI/VDE-3845

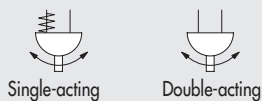

FLANGE ISO 5211	Ø i	d1
F04	42	M5 depth 8
F05	50	M6 depth 9
F07	70	M8 depth 12
F10	102	M10 depth 15
F12	125	M12 depth 18

Ø	Type	Code	Flange ISO 5211	Q	I	ØA	B	C	G	E	F	H	L	Weight [g]	
75	Double-acting	W790D075GQ011DA	F05 / F07	11	13	18	14	1/4"	20	42.5	94	100	205	2800	
		W790D075GQ014DA	F05 / F07	14	16	18	14	1/4"	20	42.5	94	100	205	2800	
		W790D075GQ017DA	F05 / F07	17	20	18	14	1/4"	20	42.5	94	100	205	2800	
		W790B075GQ011DA	F04	11	13	18	14	1/4"	20	42.5	94	100	205	2800	
		W790B075GQ014DA	F04	14	16	18	14	1/4"	20	42.5	94	100	205	2800	
		W790B075GQ017DA	F04	17	20	18	14	1/4"	20	42.5	94	100	205	2800	
	Single-acting	W790D075GQ011SR	F05 / F07	11	13	18	14	1/4"	20	42.5	94	100	205	3370	
		W790D075GQ014SR	F05 / F07	14	16	18	14	1/4"	20	42.5	94	100	205	3370	
		W790D075GQ017SR	F05 / F07	17	20	18	14	1/4"	20	42.5	94	100	205	3370	
		W790B075GQ011SR	F04	11	13	18	14	1/4"	20	42.5	94	100	205	3370	
		W790B075GQ014SR	F04	14	16	18	14	1/4"	20	42.5	94	100	205	3370	
		W790B075GQ017SR	F04	17	20	18	14	1/4"	20	42.5	94	100	205	3370	
85	Double-acting	W790D085GQ014DA	F05 / F07	14	16	18	14	1/4"	20	49	104	110	230	4200	
		W790D085GQ017DA	F05 / F07	17	20	18	14	1/4"	20	49	104	110	230	4200	
	Single-acting	W790D085GQ014SR	F05 / F07	14	16	18	14	1/4"	20	49	104	110	230	4830	
		W790D085GQ017SR	F05 / F07	17	20	18	14	1/4"	20	49	104	110	230	4830	
	100	Double-acting	W79DE100GQ014DA	F05 / F07 / F10	14	16	18	14	1/4"	20	55	120	125	275	5800
			W79DE100GQ017DA	F05 / F07 / F10	17	20	18	14	1/4"	20	55	120	125	275	5800
Single-acting		W79DE100GQ014SR	F05 / F07 / F10	14	16	18	14	1/4"	20	55	120	125	275	6820	
		W79DE100GQ017SR	F05 / F07 / F10	17	20	18	14	1/4"	20	55	120	125	275	6820	
115	Double-acting	W790E115GQ017DA	F07 / F10	17	20	36	27	1/4"	30	63.5	134	142	309	9200	
		W790E115GQ022DA	F07 / F10	22	25	36	27	1/4"	30	63.5	134	142	309	9200	
	Single-acting	W790E115GQ017SR	F07 / F10	17	20	36	27	1/4"	30	63.5	134	142	309	10300	
		W790E115GQ022SR	F07 / F10	22	25	36	27	1/4"	30	63.5	134	142	309	10300	
125	Double-acting	W790E125GQ017DA	F07 / F10	17	20	36	27	1/4"	30	69.5	141	155	362	11900	
		W790E125GQ022DA	F07 / F10	22	25	36	27	1/4"	30	69.5	141	155	362	11900	
	Single-acting	W790E125GQ017SR	F07 / F10	17	20	36	27	1/4"	30	69.5	141	155	362	14200	
		W790E125GQ022SR	F07 / F10	22	25	36	27	1/4"	30	69.5	141	155	362	14200	
145	Double-acting	W790F145GQ022DA	F10 / F12	22	25	36	27	1/4"	30	80	163	175	392	15500	
	Single-acting	W790F145GQ022SR	F10 / F12	22	25	36	27	1/4"	30	80	163	175	392	19000	

## KEY TO CODES

W79	0A	032	G	Q0	09	DA	
	FLANGE	DIAMETER	CONNECTIONS	TYPE OF POWER TAKEOFF	POWER TAKEOFF DIMENSIONS	TYPE	
Rotary actuator series R4	<b>OA</b>	F03	<b>032</b> Ø 32	<b>G</b> Supply port threading G (BSP)	<b>Q0</b> Star type (double square 45° offset)	<b>09</b> 9 mm <b>11</b> 11 mm <b>14</b> 14 mm <b>17</b> 17 mm <b>22</b> 22 mm	<b>DA</b> Double-acting
	<b>OB</b>	F04	<b>042</b> Ø 42				<b>SR</b> Single-acting
	<b>OD</b>	F05 - F07	<b>050</b> Ø 50				
	<b>OE</b>	F07 - F10	<b>063</b> Ø 63				
	<b>OF</b>	F10 - F12	<b>075</b> Ø 75				
	<b>AC</b>	F03 - F05	<b>085</b> Ø 85				
	<b>AD</b>	F03 - F05 - F07	<b>100</b> Ø 100				
	<b>DE</b>	F05 - F07 - F10	<b>115</b> Ø 115				
			<b>125</b> Ø 125				
		<b>145</b> Ø 145					

N.B.: The orderable configurations are shown on the previous pages.

## NOTES

## ACCESSORIES PARTS FOR ACTUATED VALVES SERIES RV-FLUID

### SWITCH BOX WITH ELECTROMECHANICAL MICROSWITCHES FOR ACTUATOR

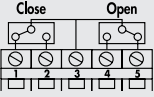

Voltage: max 125/250 VAC  
 Current: min 30 mA  
 max 2.5 A  
 Temperature: -25°C to +125°C  
 Charge: IP67

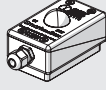

Code	Description	Weight [g]
W0900300915	Switch box with electromechanical microswitches for actuator bore 32	196

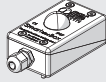

W0900300916	Switch box with electromechanical microswitches for actuator bore 42 - 63	152
-------------	---	-----

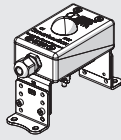

W0900300917	Switch box with electromechanical microswitches for actuator bore 115 - 145	384
-------------	---	-----

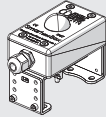

W0900300919	Switch box with electromechanical microswitches for actuator bore 75 - 100	384
-------------	--	-----

Note: switch boxes with inductive sensors and Atex certification are available on request.

### POSITION INDICATOR FOR ACTUATOR



Code	Description	Weight [g]
W0900300930	Position indicator for actuator bore 32 - 63	16



W0900300931	Position indicator for actuator bore 75 - 100	22
-------------	---	----



W0900300933	Position indicator for actuator bore 32 - 100 (only without switch box)	52
-------------	---	----



W0900300932	Position indicator for actuator bore 115 - 145	26
-------------	--	----

### CONTROL VALVES WITH NAMUR INTERFACE

Refer to page B1.47

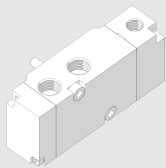



### KIT SQUARED ADAPTOR

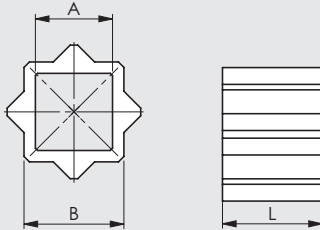

Code	Description	A	B	L	Weight [g]
W0900301001	Kit squared adaptor RV-FLUID 08/11	8	11	12	7
W0900301002	Kit squared adaptor RV-FLUID 09/11	9	11	12	6
W0900301006	Kit squared adaptor RV-FLUID 09/13	9	13	12	11
W0900301007	Kit squared adaptor RV-FLUID 11/13	11	13	12	7
W0900301008	Kit squared adaptor RV-FLUID 11/14	11	14	16	13
W0900301003	Kit squared adaptor RV-FLUID 14/17	14	17	17	19
W0900301005	Kit squared adaptor RV-FLUID 14/22	14	22	22	65
W0900301009	Kit squared adaptor RV-FLUID 16/22	16	22	22	52
W0900301004	Kit squared adaptor RV-FLUID 17/22	17	22	22	48

Note: adaptors according to ISO 5211 - DIN 3337 in AISI 316 stainless steel

### SPRINGS KIT FOR SINGLE-ACTING VERSION

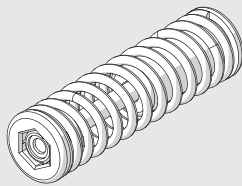

Code	Ø	Quantity per kit
W0900303002	42	8
W0900303003	50	12
W0900303004	63	12
W0900303005	75	12
W0900303006	85	12
W0900303007	100	12
W0900303008	115	12
W0900303009	125	12
W0900303010	145	12

Note: the springs are supplied pre-compressed with a special support to facilitate installation. Do not remove the spring from its support for any reason whatsoever.

## SPARES PARTS FOR ACTUATED VALVES SERIES RV-FLUID

### GASKETS KIT AND SLIDING ELEMENTS

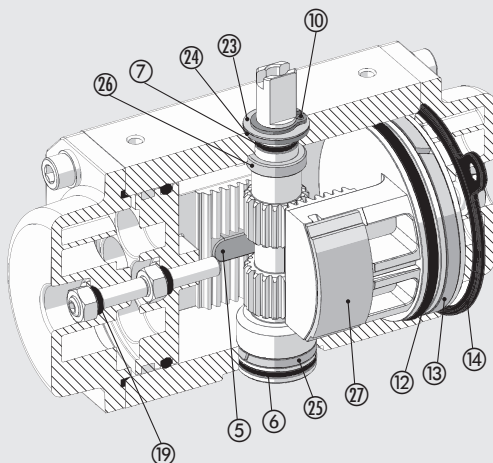

Code	Ø	Parts
W0900302001	32	6-7-10-12-13-14-19-23-24-25-26-27
W0900302002	42	5-6-7-10-12-13-14-19-23-24-25-26-27
W0900302003	50	5-6-7-10-12-13-14-19-23-24-25-26-27
W0900302004	63	5-6-7-10-12-13-14-19-23-24-25-26-27
W0900302005	75	5-6-7-10-12-13-14-19-23-24-25-26-27
W0900302006	85	5-6-7-10-12-13-14-19-23-24-25-26-27
W0900302007	100	5-6-7-10-12-13-14-19-23-24-25-26-27
W0900302008	115	5-6-7-10-12-13-14-19-23-24-25-26-27
W0900302009	125	5-6-7-10-12-13-14-19-23-24-25-26-27
W0900302010	145	5-6-7-10-12-13-14-19-23-24-25-26-27