

# Stoßdämpfer · Shock Absorbers

Amortisseurs · Deceleratori · Amortiguadores



## D

**Hohe Energieaufnahme bis zu 11520 kNm/h**

### Dämpfung

WS-M: selbsteinstellend

WE-M: einstellbar

Lange Lebensdauer

Kolbenstange hartverchromt & gehärtet

Gehäuse verzinkt

Temperaturbereich

-20°C - +80°C

Optional

Niedrigere oder höhere

Aufprallgeschwindigkeiten

Niedrigere oder höhere Temperaturen

## GB

**High energy absorption up to 11520 kNm/h**

### Deceleration

WS-M: self-compensating

WE-M: adjustable

Extended Life Time

Piston rod: hardened /

hard chrome-plated

Housing: zinc plated

Temperature range

-20°C - +80°C

Optional

Lower or higher impact speed

Lower or higher temperatures

## F

**Absorption d'énergie élevé jusqu'à 11520 kNm/h**

### Décélération

WS-M: auto-compensé

WE-M: réglable

Longévité

Tige de piston: trempé /

acier chromé dur

Corps: acier zingué

Températures

-20°C - +80°C

En option

Vitesse d'impact inférieure ou

supérieure

Températures inférieures ou supérieures

## I

**Alto assorbimento di energia fino a 11520 kNm/h**

### Smorzamento

WS-M: auto-compensante

WE-M: regolabile

Lunga durata

Stelo del pistone: temprato /

acciaio cromato

Corpo: acciaio zincato

Temperatura

-20°C - +80°C

Opzionale

Velocità d'impatto inferiore o superiore

Temperature inferiori o superiori

## E

**Absorción de energía elevada de hasta 11520 kNm/h**

### Amortiguación

WS-M: auto-compensado

WE-M: regulable

Larga vida útil

Vástago del émbolo: cromado duro /

templado

Carcasa: galvanizada

Temperaturas

-20°C - +80°C

Opcional

Velocidad de impacto bajo o más alto

Temperaturas más bajas o más altas

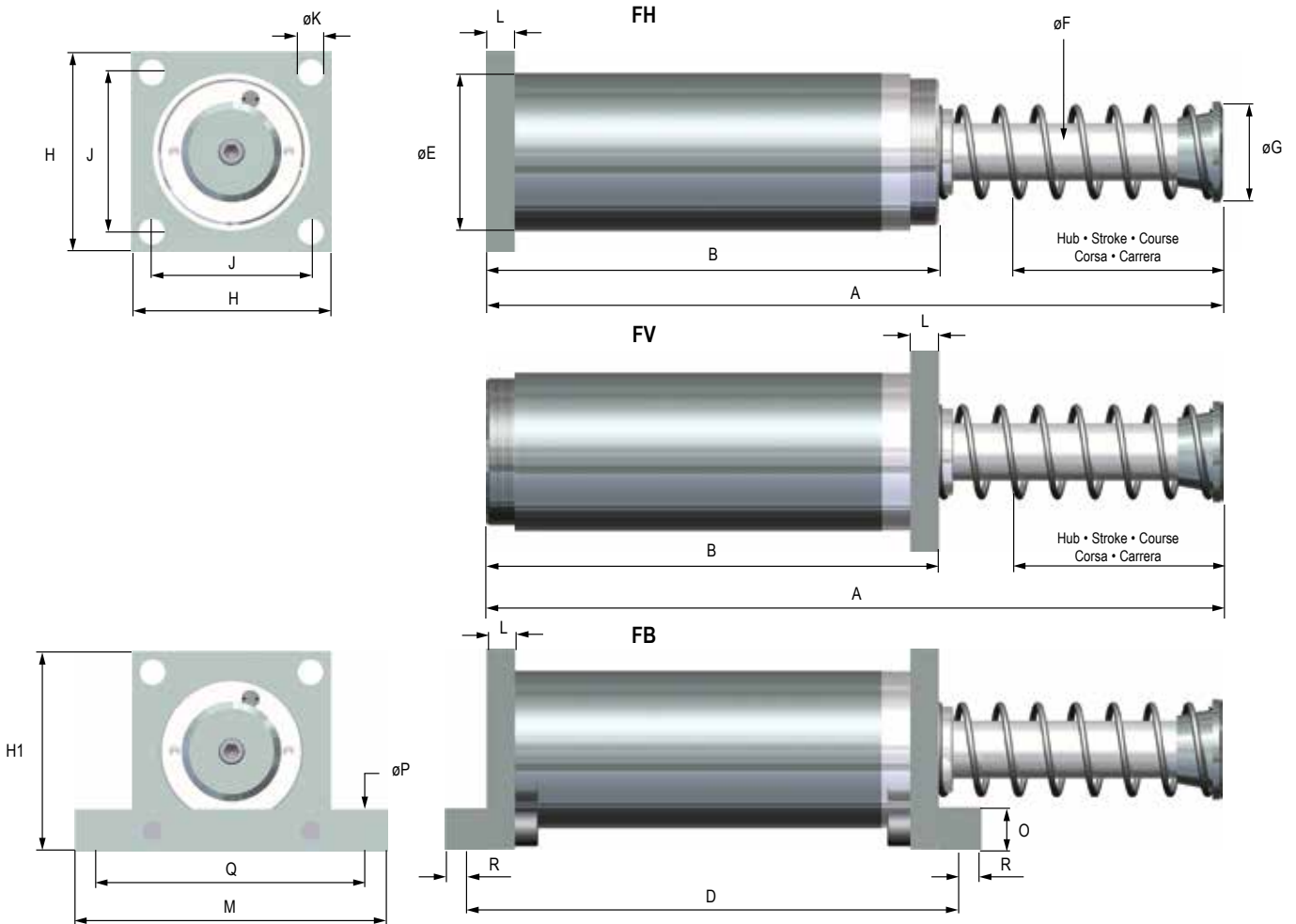

Festensschlag 2 – 3 mm vor Hubende vorsehen  
 End stop required 2 – 3 mm before the stroke ends  
 Butée de fin de course nécessaire 2-3 mm avant la fin de course  
 Fine corsa richiesti 2 – 3 mm prima che la corsa finisca  
 Tope fijo requerido 2-3 mm antes de que termine la carrera

Anschlagkappe PU\* • Stop cap PU\* • Chapeau butoir PU\* • Testina d'urto PU\* • Cabeza de choque PU\*

*"A" zur Artikelbezeichnung hinzufügen / Add "A" after the part no.  
 À la commande, ajouter la lettre "A" en fin de référence  
 Aggiungere la lettera "A" alla fine del codice d'ordine  
 Añadir la letra "AS" al final de la referencia*

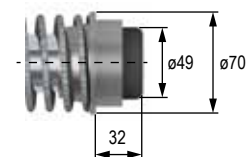

### ABMESSUNGEN • DIMENSIONS • DIMENSIONI • DIMENSIONES

	A	B	D	øE	øF	øG	H	J	øK	L	M	H1	O	øP	Q	R	Gewicht - Weight Poids - Peso - Peso
	mm	mm	mm	mm	mm	mm	mm	mm	mm	mm	mm	mm	mm	mm	mm	mm	kg
WS-M 5,0-050	313	214	244	110	40	70	140	111	18	20	220	140	30	18	178	15	14
WS-M 5,0-100	414	262	292	110	40	70	140	111	18	20	220	140	30	18	178	15	16
WS-M 5,0-150	516	317	347	110	40	70	140	111	18	20	220	140	30	18	178	15	18
WS-M 5,0-200	648	361	391	110	40	70	140	111	18	20	220	140	30	18	178	15	20
WS-M 5,0-250	750	413	443	110	40	70	140	111	18	20	220	140	30	18	178	15	24

### LEISTUNGEN • PERFORMANCE • CARATTERISTICHE TECNICHE • CARACTERÍSTICAS TÉCNICAS

	Hub Stroke Course Corsa Carrera	Energieaufnahme Energy absorption Energie d'absorption Assorbimento d'energia Absorción de energía	Effektive Masse - Effective mass - Masse effective Massa efectiva - Masa efectiva								Aufprallgeschwindigkeit Impact Speed Vitesse d'impact Velocità d'impatto Velocidad de impacto	Rückholfederkraft Return spring force Force du ressort Forza di ritorno Fuerza del muelle recuperador	
			-1 (soft)		-2 (medium)		-3 (hard)		-4 (very hard)				
	mm	Nm / HB (max.)	Nm/h (max.)	min. kg	max. kg	min. kg	max. kg	min. kg	max. kg	min. kg	max. kg	m/s	N
WS-M 5,0-050	50	4000	1200000	690	2470	2000	5555	4730	14220	12500	39500	0,3 - 3,4	100 - 400
WS-M 5,0-100	100	8000	1520000	1380	4930	4000	11110	9460	28440	25000	79000	0,3 - 3,4	100 - 400
WS-M 5,0-150	150	11000	1650000	1900	6790	5500	15280	13000	39110	34375	108640	0,3 - 3,4	100 - 400
WS-M 5,0-200	200	15000	1950000	2595	9260	7500	20830	17750	53330	46875	148150	0,3 - 3,4	100 - 400
WS-M 5,0-250	250	19000	2280000	3290	11730	9500	26390	22485	67555	59375	187650	0,3 - 3,4	100 - 400

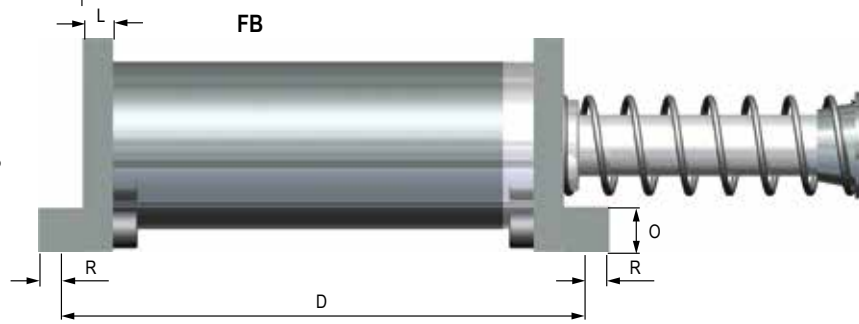
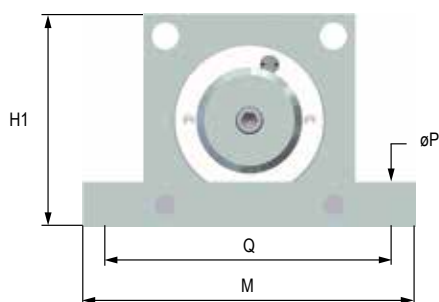
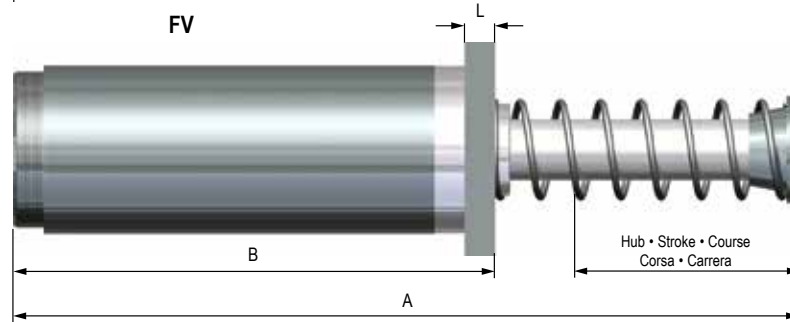
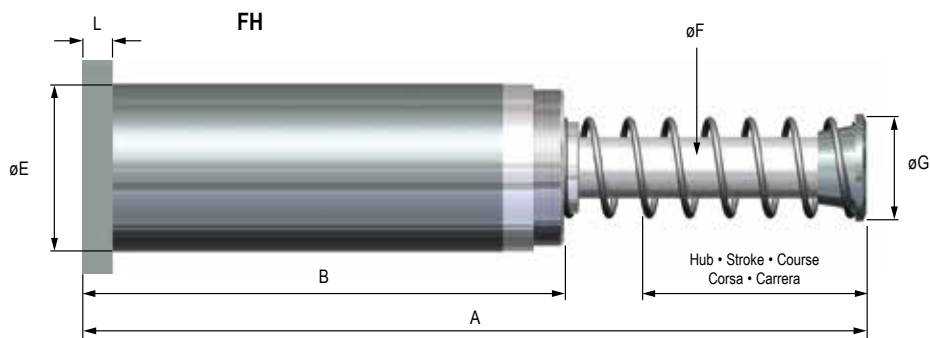
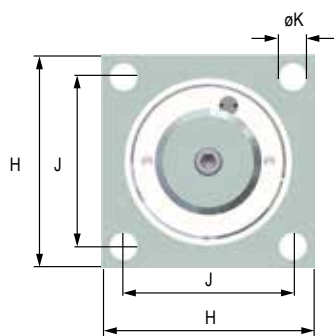

Festanschlag 2 – 3 mm vor Hubende vorsehen  
 End stop required 2 – 3 mm before the stroke ends  
 Butée de fin de course nécessaire 2-3 mm avant la fin de course  
 Fine corsa richiest 2 – 3 mm prima che la corsa finisca  
 Tope fijo requerido 2-3 mm antes de que termine la carrera

Anschlagkappe PU\* • Stop cap PU\* • Chapeau butoir PU\* • Testina d'urto PU\* • Cabeza de choque PU\*

"A" zur Artikelbezeichnung hinzufügen / Add "A" after the part no.  
 À la commande, ajouter la lettre "A" en fin de référence  
 Aggiungere la lettera "A" alla fine del codice d'ordine  
 Añadir la letra "AS" al final de la referencia

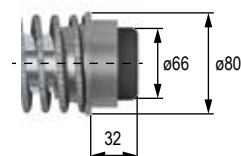

## ABMESSUNGEN • DIMENSIONS • DIMENSIONI • DIMENSIONES

	A	B	D	øE	øF	øG	H	J	øK	L	M	H1	O	øP	Q	R	Gewicht - Weight Poids - Peso Peso
	mm	mm	mm	mm	mm	mm	mm	mm	mm	mm	mm	mm	mm	mm	mm	mm	kg
WS-M 7,5-125	490	301	333	130	45	80	170	125	22	20	255	160	40	22	216	24	29
WS-M 7,5-200	641	376	408	130	45	80	170	125	22	20	255	160	40	22	216	24	34
WS-M 7,5-300	895	471	503	130	45	80	170	125	22	20	255	160	40	22	216	24	41

## LEISTUNGEN • PERFORMANCE • CARATTERISTICHE TECNICHE • CARACTERÍSTICAS TÉCNICAS

	Hub Stroke Course Corsa Carrera	Energieaufnahme Energy absorption Energie d'absorption Assorbimento d'energia Absorción de energia	Effektive Masse - Effective mass - Masse effective Massa efectiva - Masa efectiva								Aufprallgeschwindigkeit Impact Speed Vitesse d'impact Velocità d'impatto Velocidad de impacto		Rückholfederkraft Return spring force Force du ressort Forza di ritorno Fuerza del muelle recuperador	
			-1 (soft)		-2 (medium)		-3 (hard)		-4 (very hard)		m/s			N
	mm	Nm / HB (max.)	Nm/h (max.)	min. kg	max. kg	min. kg	max. kg	min. kg	max. kg	min. kg	max. kg	m/s		N
WS-M 7,5-125	125	16000	2560000	2770	9870	8000	22200	18935	56880	50000	158025	0,3 - 3,4		200 - 450
WS-M 7,5-200	200	25000	4000000	4325	15430	12500	34720	29585	88880	78125	246910	0,3 - 3,4		200 - 450
WS-M 7,5-300	300	37000	5920000	6400	22840	18500	51390	43790	131555	115625	365430	0,3 - 3,4		200 - 450

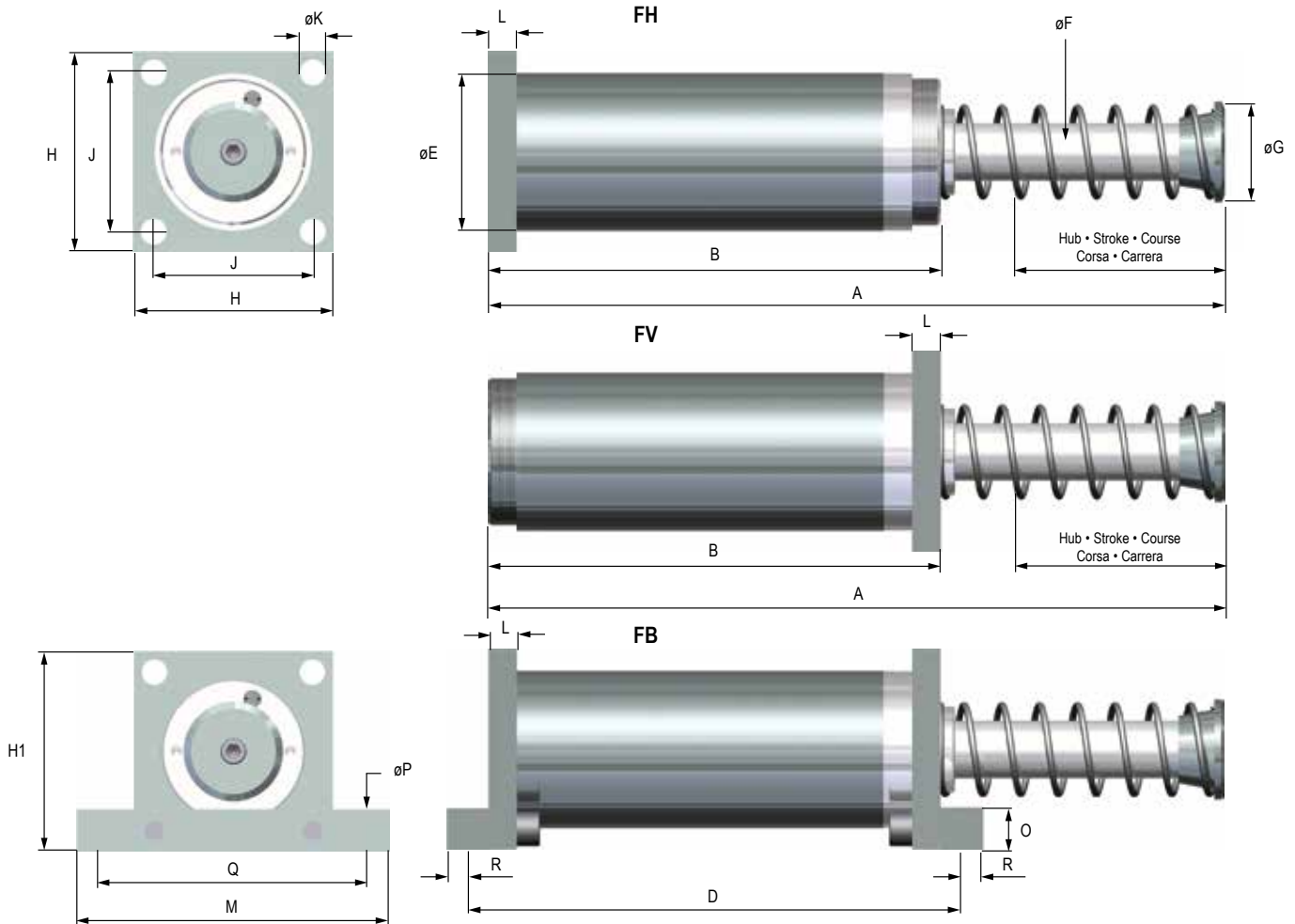

Festanschlag 2 – 3 mm vor Hubende vorsehen  
 End stop required 2 – 3 mm before the stroke ends  
 Butée de fin de course nécessaire 2-3 mm avant la fin de course  
 Fine corsa richiest 2 – 3 mm prima che la corsa finisca  
 Tope fijo requerido 2-3 mm antes de que termine la carrera

Anschlagkappe PU\* • Stop cap PU\* • Chapeau butoir PU\* • Testina d'urto PU\* • Cabeza de choque PU\*

"A" zur Artikelbezeichnung hinzufügen / Add "A" after the part no.  
 À la commande, ajouter la lettre "A" en fin de référence  
 Aggiungere la lettera "A" alla fine del codice d'ordine  
 Añadir la letra "AS" al final de la referencia

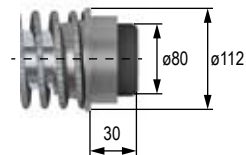

**ABMESSUNGEN - DIMENSIONS - DIMENSIONI - DIMENSIONES**

	A	B	D	øE	øF	øG	H	J	øK	L	M	H1	O	øP	Q	R	Gewicht - Weight Poids - Peso Peso kg
	mm	mm	mm	mm	mm	mm	mm	mm	mm	mm	mm	mm	mm	mm	mm	mm	kg
WS-M 10,0-150	716	434	484	200	65	112	250	197	22	40	360	254	50	27	317	25	60
WS-M 10,0-200	818	536	586	200	65	112	250	197	22	40	360	254	50	27	317	25	68
WS-M 10,0-400	1300	733	783	200	65	112	250	197	22	40	360	254	50	27	317	25	146

**LEISTUNGEN - PERFORMANCE - CARATTERISTICHE TECNICHE - CARACTERÍSTICAS TÉCNICAS**

	Hub Stroke Course Corsa Carrera	Energieaufnahme Energy absorption Energie d'absorption Assorbimento d'energia Absorción de energia	Effektive Masse - Effective mass - Masse effective Massa efectiva - Masa efectiva								Aufprallgeschwindigkeit Impact Speed Vitesse d'impact Velocità d'impatto Velocidad de impacto		Rückholfederkraft Return spring force Force du ressort Forza di ritorno Fuerza del muelle recuperador				
			-1 (soft)	-2 (medium)	-3 (hard)	-4 (very hard)	min. kg	max. kg	min. kg	max. kg	min. kg	max. kg		m/s	N		
	mm	Nm / HB (max.)	Nm/h (max.)	min. kg	max. kg	min. kg	max. kg	min. kg	max. kg	min. kg	max. kg						
WS-M 10,0-150	150	50000	3150000	3500	9180	8650	18900	17360	44440	-	-	0,3 - 5,0	350 - 900				
WS-M 10,0-200	200	65000	3575000	4630	11930	11250	24570	22570	57700	-	-	0,3 - 5,0	350 - 900				
WS-M 10,0-400	400	128000	11520000	9115	23500	22145	48395	44440	113770	-	-	0,3 - 5,0	350 - 900				

# Mega-Line WE-M 5,0

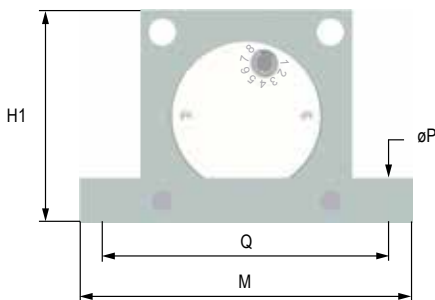
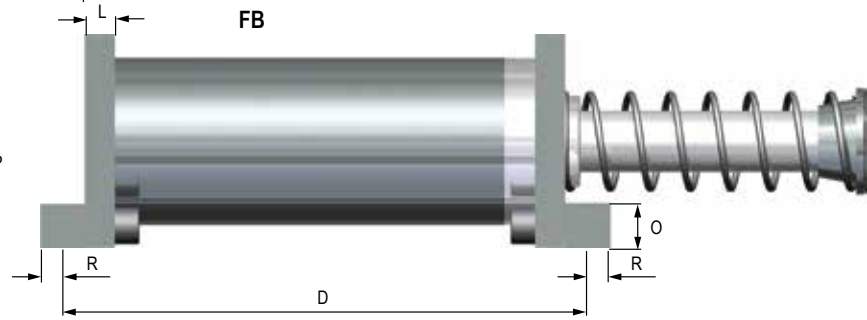
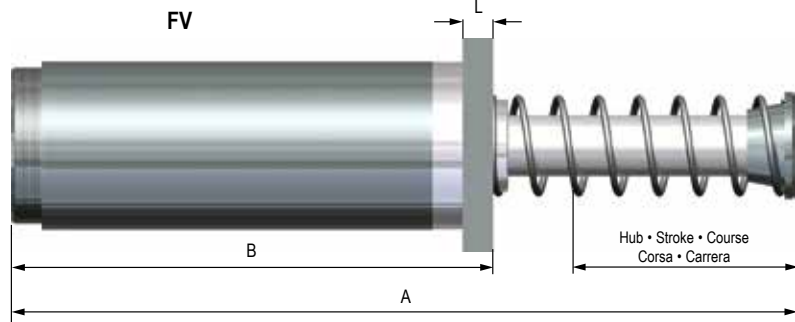
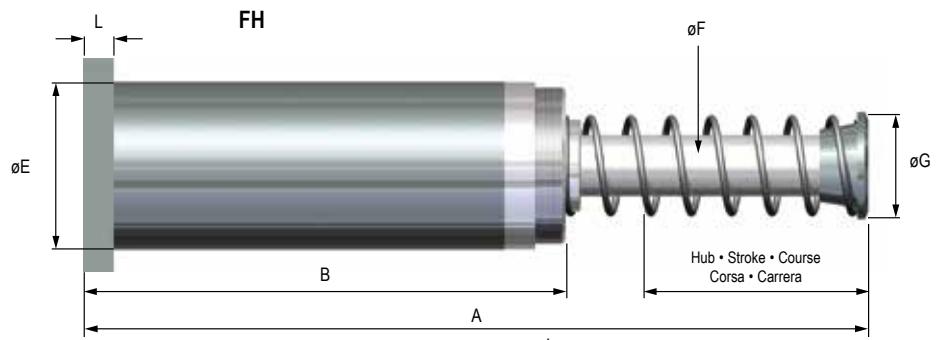
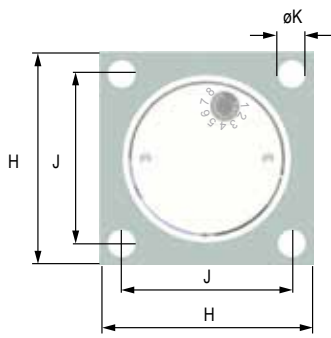

Festanschlag 2 – 3 mm vor Hubende vorsehen  
 End stop required 2 – 3 mm before the stroke ends  
 Butée de fin de course nécessaire 2-3 mm avant la fin de course  
 Fine corsa richiesta 2 – 3 mm prima che la corsa finisca  
 Tope fijo requerido 2-3 mm antes de que termine la carrera

Anschlagkappe PU\* • Stop cap PU\* • Chapeau butoir PU\* • Testina d'urto PU\* • Cabeza de choque PU\*

"A" zur Artikelbezeichnung hinzufügen / Add "A" after the part no.  
 À la commande, ajouter la lettre "A" en fin de référence  
 Aggiungere la lettera "A" alla fine del codice d'ordine  
 Añadir la letra "AS" al final de la referencia

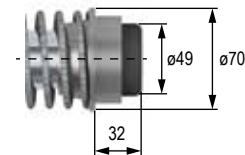

## ABMESSUNGEN - DIMENSIONS - DIMENSIONI - DIMENSIONES

	A	B	D	øE	øF	øG	H	J	øK	L	M	H1	O	øP	Q	R	Gewicht - Weight Poids - Peso Peso
	mm	mm	mm	mm	mm	mm	mm	mm	mm	mm	mm	mm	mm	mm	mm	mm	kg
WE-M 5,0-050	313	214	244	110	40	70	140	111	18	20	220	140	30	18	178	15	14
WE-M 5,0-100	414	262	292	110	40	70	140	111	18	20	220	140	30	18	178	15	16
WE-M 5,0-150	516	317	347	110	40	70	140	111	18	20	220	140	30	18	178	15	18
WE-M 5,0-200	648	361	391	110	40	70	140	111	18	20	220	140	30	18	178	15	20
WE-M 5,0-250	750	413	443	110	40	70	140	111	18	20	220	140	30	18	178	15	24

## LEISTUNGEN - PERFORMANCE - CARATTERISTICHE TECNICHE - CARACTERÍSTICAS TÉCNICAS

	Hub Stroke Course Corsa Carrera	Energieaufnahme Energy absorption Energie d'absorption Assorbimento d'energia Absorción de energía	Effektive Masse - Effective mass Masse effective - Massa effettiva Masa efectiva	Rückholfederkraft Return spring force Force du ressort Forza di ritorno Fuerza del muelle recuperador
	mm	Nm / HB (max.) Nm/h (max.)	min. kg max. kg	N
WE-M 5,0-050	50	4000	260	100 - 400
WE-M 5,0-100	100	9000	280	100 - 400
WE-M 5,0-150	150	14000	430	100 - 400
WE-M 5,0-200	200	20000	625	100 - 400
WE-M 5,0-250	250	24000	750	100 - 400

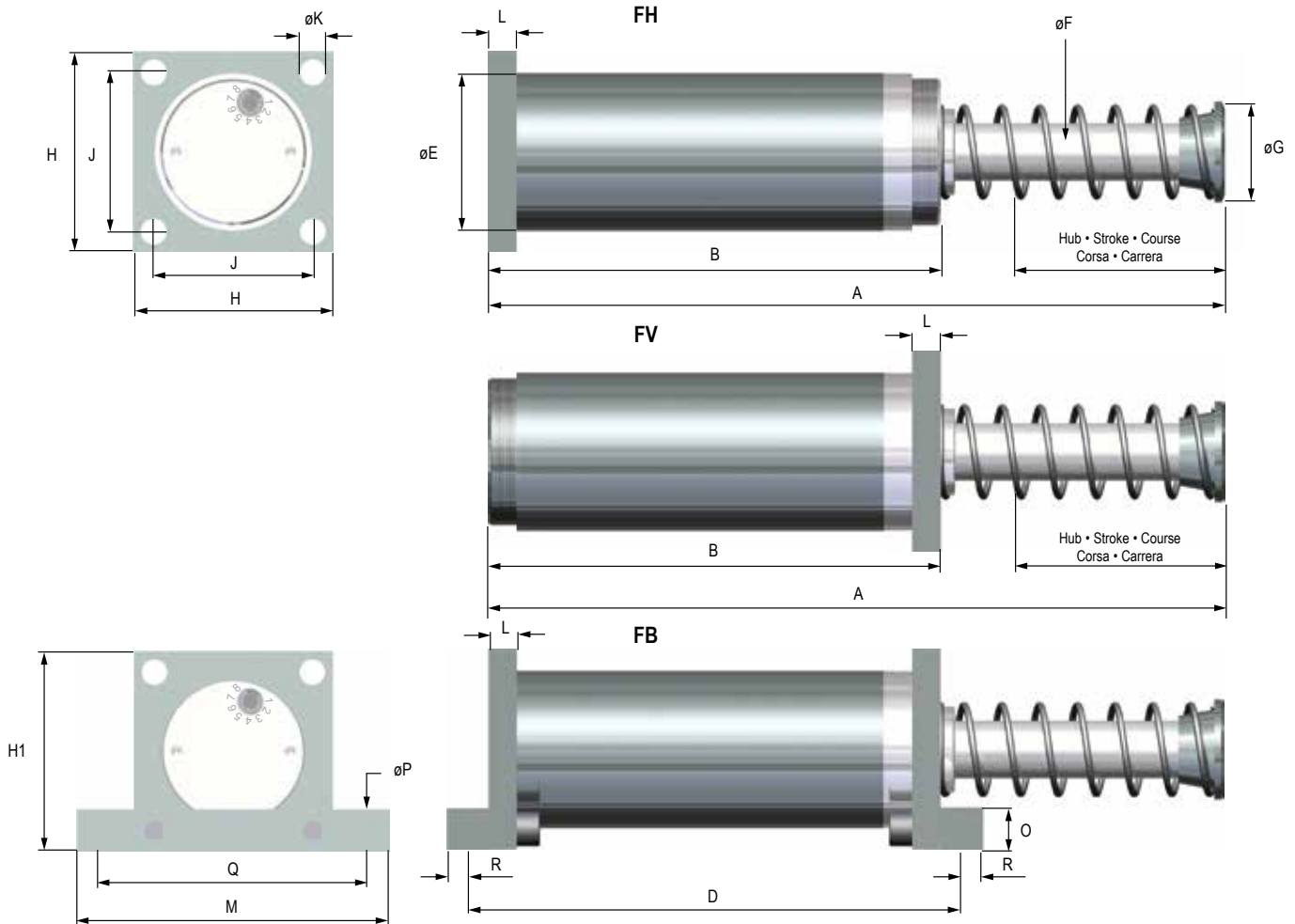

Festanschlag 2 – 3 mm vor Hubende vorsehen  
 End stop required 2 – 3 mm before the stroke ends  
 Butée de fin de course nécessaire 2-3 mm avant la fin de course  
 Fine corsa richiest 2 – 3 mm prima che la corsa finisca  
 Tope fijo requerido 2-3 mm antes de que termine la carrera

Anschlagkappe PU\* • Stop cap PU\* • Chapeau butoir PU\* • Testina d'urto PU\* • Cabeza de choque PU\*

*"A" zur Artikelbezeichnung hinzufügen / Add "A" after the part no.  
 À la commande, ajouter la lettre "A" en fin de référence  
 Aggiungere la lettera "A" alla fine del codice d'ordine  
 Añadir la letra "AS" al final de la referencia*

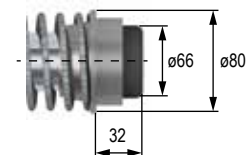

**ABMESSUNGEN • DIMENSIONS • DIMENSIONI • DIMENSIONES**

	A	B	D	øE	øF	øG	H	J	øK	L	M	H1	O	øP	Q	R	Gewicht - Weight Poids - Peso Peso
	mm	mm	mm	mm	mm	mm	mm	mm	mm	mm	mm	mm	mm	mm	mm	mm	kg
WE-M 7,5-125	490	301	333	130	45	80	170	125	22	20	255	160	40	22	216	24	29
WE-M 7,5-200	641	376	408	130	45	80	170	125	22	20	255	160	40	22	216	24	34
WE-M 7,5-300	895	471	503	130	45	80	170	125	22	20	255	160	40	22	216	24	41

**LEISTUNGEN • PERFORMANCE • CARATTERISTICHE TECNICHE • CARACTERÍSTICAS TÉCNICAS**

	Hub Stroke Course Corsa Carrera	Energieaufnahme Energy absorption Energie d'absorption Assorbimento d'energia Absorción de energía	Effektive Masse - Effective mass Masse effective - Massa effettiva Masa efectiva				Rückholfederkraft Return spring force Force du ressort Forza di ritorno Fuerza del muelle recuperador	
			-0	max. kg	min. kg	-1		
	mm	Nm / HB (max.)	Nm/h (max.)	min. kg	max. kg	min. kg	max. kg	N
WE-M 7,5-125	125	16000	2320000	500	1580	1280	158000	200 - 450
WE-M 7,5-200	200	28000	3640000	875	2765	2240	224000	200 - 450
WE-M 7,5-300	300	44000	5280000	1375	4345	3520	244000	200 - 450