

TWIN CYLINDER SERIES S10

There are two sliding systems available:

- on bushes
- on ball recirculating bearings

The frame is made up of two paired cylinders with a common anodized aluminium body containing slots for retracting sensors.

There are 5 bores available:

2 x Ø 12, 2 x Ø 16, 2 x Ø 20, 2 x Ø 25 and 2 x Ø 30.

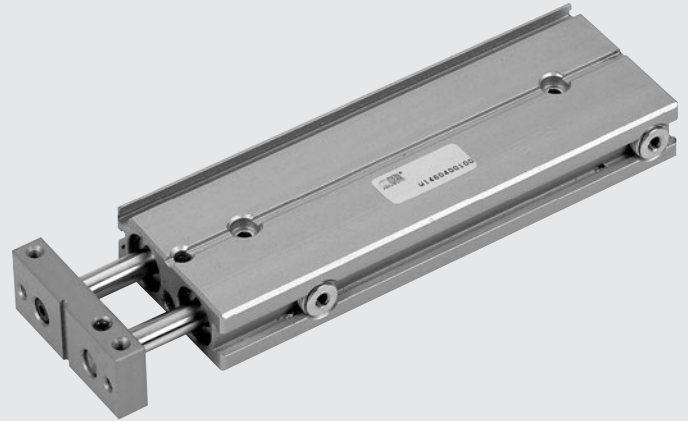

TECHNICAL DATA		S10-12	S10-16	S10-20	S10-25	S10-30
Pressure range	bar	3 to 7				
	MPa	0.3 to 0.7				
	psi	43.5 to 101				
Temperature range	°C	-10 to +80				
Fluid		20 µm dried or lubricated filtered air. Lubrication, if used, must be continuous.				
Piston speed	mm/s	30 to 100				
Versions		System with sliding bushes/System with ball bushes available with stop screw or hydraulic decelerator				
Sizes		12	16	20	25	30
Bores	mm	2 x 12	2 x 16	2 x 20	2 x 25	2 x 30
Piston rod diameter	mm	6	8	10	12	16
	mm	15	15	25	25	25
Strokes	mm	25	25	50	50	50
	mm	50	50	75	75	75
	mm	-	75	100	100	100
Weight (C = stroke mm)						
	Bushes version	kg	0.12 + (0.002 x C)	0.24 + (0.0025 x C)	0.51 + (0.005 x C)	0.76 + (0.006 x C)
Ball bearing version	kg	0.21 + (0.002 x C)	0.48 + (0.0025 x C)	0.77 + (0.005 x C)	0.18 + (0.006 x C)	1.92 + (0.009 x C)
Maximum impact energy	J	0.10	0.15	0.20	0.30	0.5
Theoretical thrust (P = relative pressure in bar)		(Multiply the value shown by the pressure in bar)				
Thrust force	da N	2.26 x P	4 x P	6.28 x P	9.8 x P	14.1 x P
Pull force	da N	1.69 x P	3 x P	4.11 x P	7.5 x P	10.1 x P
Max. loads		(The values shown refer to the min. and max. strokes)				
Bushes version	N	6 to 4	11 to 6	20 to 7	26 to 8	36 to 11
Ball bearing version	N	3 to 1.5	6 to 3	10 to 3.5	12 to 5.6	20 to 7

COMPONENTS

- ① FLANGE: anodized aluminium
- ② REAR BASE: anodized aluminium
- ③ BUFFER: rubber
- ④ ADJUSTABLE STRIKER PLATE. Zinc-plated steel
- ④bis HYDRAULIC DECELERATOR
- ⑤ FRONT BASE: brass
- ⑥ PISTON: brass
- ⑦ MAGNET: Plastroferrite
- ⑧ CYLINDER BODY: anodized aluminium
- ⑨ STATIC O-RING: NBR
- ⑩ BALL RE-CIRCULATION BUSH
- ⑪ PISTON ROD: grinded chromed stainless steel
- ⑫ PISTON ROD: tempered chrome stainless steel, grinded

VERSIONS:

- Ⓐ With sliding bushes
- Ⓑ With ball bushes

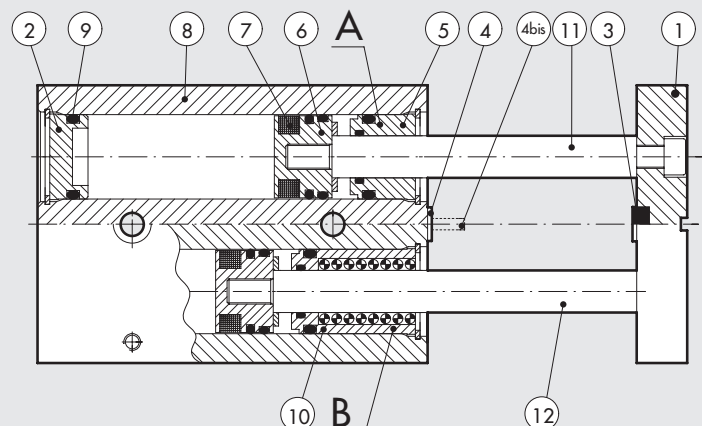

DIMENSIONS OF TWIN CYLINDER SERIES S10, ON BUSHES Ø 12 to 30 mm

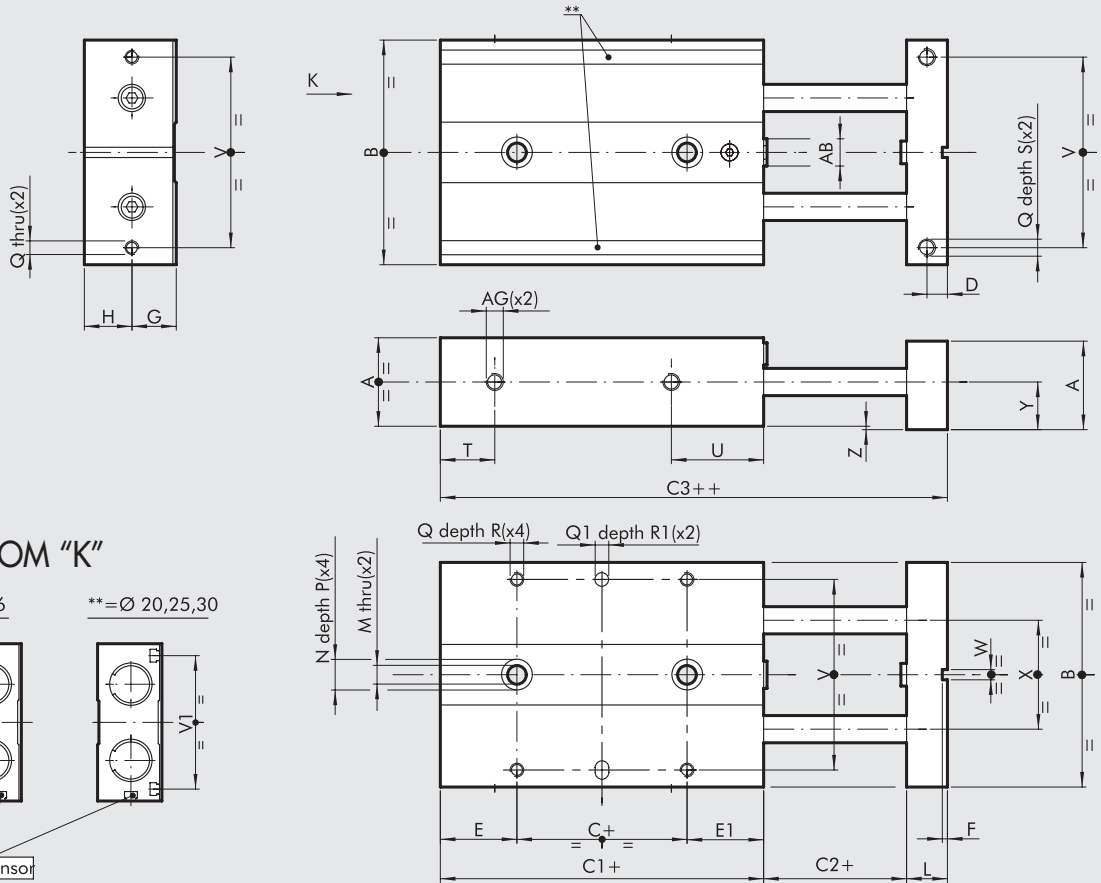

+ = ADD THE STROKE
 ++ = ADD TWICE THE STROKE

Code	Ø	A	B	C	C1	C2	C3	D	E	E1	F	G	H	L	M	N	P	Q	Q1 ^{H7}	R	R1	S	T
W1440122...	12	18	46	10	50	2	60	4	20	20	1.5	9	10	8	4.3	8	4	M3	4	5	3	8	9
W1440162...	16	22	56	16	62	2	74	5	26	20	1.5	11	12	10	4.3	8	4	M4	4	6	3	8	10
W1440202...	20	26	66	10	68	2	82	6	29	29	1.5	13	14	12	5.5	9	5	M4	4	7	3	10	11
W1440252...	25	32	78	10	74	2	90	7	32.5	31.5	2.5	16	17	14	6.5	10.5	6	M5	4	7	3	12	11
W1440302...	30	36	98	10	87	2	105	8	37.5	39.5	2.5	18	19	16	8.5	14	8	M6	6	8	5	12	13

Ø	U	V	V1	W	X	Y	Z	AB	AG
12	28	38	-	3	20	10	1	M5	M5
16	33	46	-	3	26	12	1	M6	M5
20	40	56	54	3	30	14	1	M8	M5
25	42	66	64	5	39	17	1	M10	M5
30	51	86	82	5	52	19	1	M12	G 1/8"

...Enter the stroke in mm (e.g. Ø 12 stroke 50 = W1440122050)

- Strokes for bore 12 mm 15; 25; 50;
- Strokes for bore 16 mm 15; 25; 50; 75;
- Strokes for bore 20 mm 25; 50; 75; 100;
- Strokes for bore 25 mm 25; 50; 75; 100; 125;
- Strokes for bore 30 mm 25; 50; 75; 100; 125;

DIMENSIONS OF TWIN CYLINDER SERIES S10, ON BALL BEARINGS Ø 12 to 30 mm

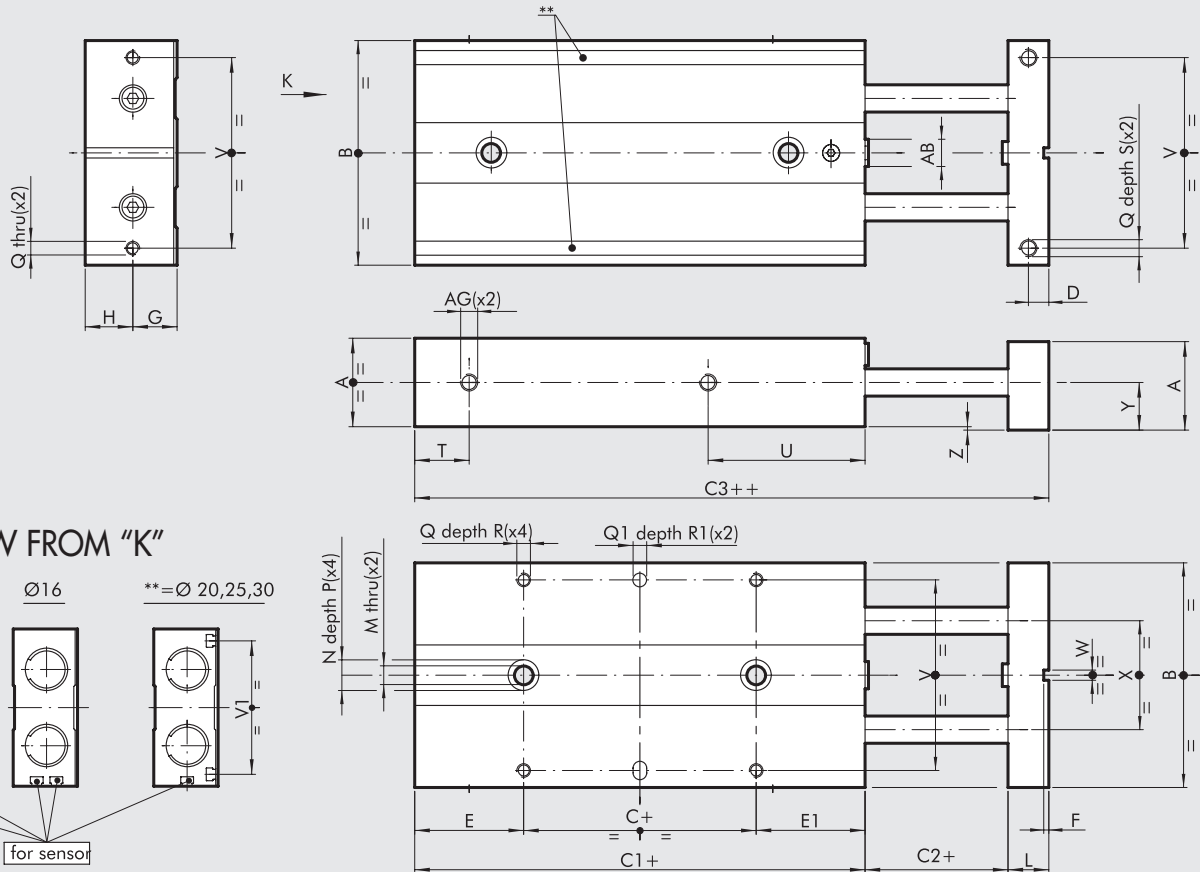

+ = ADD THE STROKE
 ++ = ADD TWICE THE STROKE

Code	Ø	A	B	C	C1	C2	C3	D	E	E1	F	G	H	L	M	N	P	Q	Q1 ^{H7}	R	R1	S	T
W1440123...	12	18	46	10	69	2	79	4	29.5	29.5	1.5	9	10	8	4.3	8	4	M3	4	5	3	8	9
W1440163...	16	22	56	10	90	2	98	5	42	38	1.5	11	12	10	4.3	8	4	M4	4	6	3	8	10
W1440203...	20	26	66	10	100	2	111	6	46.5	43.5	1.5	13	14	12	5.5	9	5	M4	4	7	3	10	11
W1440253...	25	32	78	10	108	2	120	7	51.5	46.5	2.5	16	17	14	6.5	10.5	6	M5	4	7	3	12	11
W1440303...	30	36	98	10	124	2	142	8	56	58	2.5	18	19	16	8.5	14	8	M6	6	8	5	12	13

Ø	U	V	V1	W	X	Y	Z	AB	AG
12	47	38	-	3	20	10	1	M5	M5
16	57	46	-	3	26	12	1	M6	M5
20	69	56	54	3	30	14	1	M8	M5
25	72	66	64	5	39	17	1	M10	M5
30	88	86	82	5	52	19	1	M12	G 1/8"

...Enter the stroke in mm (e.g. Ø 12 stroke 50 = W1440123050)

- Strokes for bore 12 mm 15; 25; 50;
- Strokes for bore 16 mm 15; 25; 50; 75;
- Strokes for bore 20 mm 25; 50; 75; 100;
- Strokes for bore 25 mm 25; 50; 75; 100; 125;
- Strokes for bore 30 mm 25; 50; 75; 100; 125;

ACCESSORIES

SENSOR Ø 4, FOR SLIDE S10 Ø 12

For codes and technical data, see [chapter A6](#).

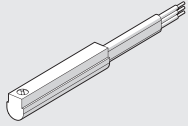

RETRACTABLE SENSOR, FOR SLIDE S10 Ø16 to 30

For codes and technical data, see [chapter A6](#).

SENSOR, SQUARE TYPE
Latest generation,
secure fixing

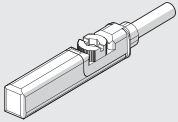

SENSOR, OVAL TYPE
Traditional

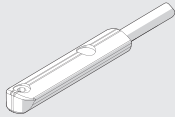

NOTES