

TWIN CYLINDER SLIDE WITH FIXED PLATES SERIES S12

METAL[®]
WORK
P N E U M A T I C

Two sliding systems are available:

- on bushes
- on ball bearings

The structure is made up of two paired through-rod cylinders with a common anodized aluminium body with grooves for mounting the retractable sensor.

Five bores available: 2 x Ø 16; 2 x Ø 20; 2 x Ø 25; 2 x Ø 30.

The rods are joined together by means of a plate on which the mechanical limit switches or hydraulic shock absorbers can be mounted.

The compressed air ports are at the end of the piston rods.

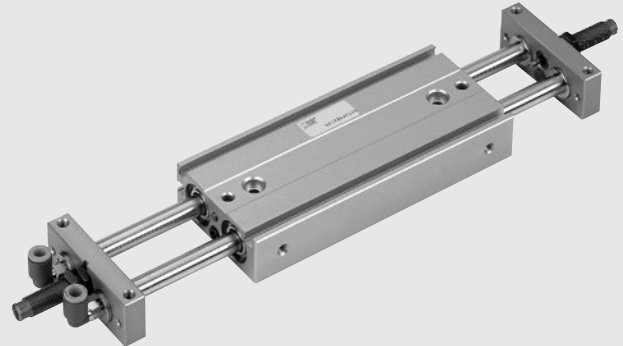

TECHNICAL DATA		S12-16	S12-20	S12-25	S12-30	
Fluid		20 µm filtered air				
Pressure range	bar	1.5 to 7				
	MPa	0.15 to 0.7				
	psi	21.5 to 101				
Temperature range	°C	-10 to +80				
Piston speed	mm/s	30 to 200				
Versions		With sliding bushes / With ball bearing bushes / With stop screw / With hydraulic shock absorbers				
Bores	mm	16	20	25	30	
Piston rod diameter	mm	8	10	12	16	
Strokes	mm	25	25	25	25	
		50	50	50	50	
		75	75	75	75	
		100	100	100	100	
		-	125	125	125	
Weight = X + (Y · C) where C = stroke	kg					
	Bushes version	X = 0.25 Y = 0.0035	X = 0.5 Y = 0.045	X = 0.7 Y = 0.007	X = 1.24 Y = 0.01	
Ball bearing version		X = 0.37 Y = 0.0035	X = 0.78 Y = 0.045	X = 1.04 Y = 0.007	X = 1.98 Y = 0.01	
	Maximum impact energy with buffers	J	0.15	0.20	0.30	0.5
Maximum impact energy with hydraulic decelerators	J	5	5	10	20	
Theoretical thrust (P = relative pressure in bar)	N	30 x P	47 x P	75 x P	101 x P	
Max. loads		(The values shown refer to the min. and max. strokes)				
	Bushes version	N	Fr: 35 to 6.5 Fp: 11 to 3	Fr: 58 to 7 Fp: 18 to 5	Fr: 80 to 8 Fp: 23 to 6	Fr: 130 to 18 Fp: 50 to 8
Ball bearing version		N	Fr: 20 to 4 Fp: 4 to 1.5	Fr: 35 to 4.5 Fp: 12 to 3	Fr: 50 to 5.4 Fp: 15 to 3.5	Fr: 80 to 12 Fp: 20 to 4.5

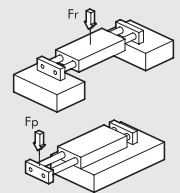

COMPONENTS

- ① FLANGE: anodized aluminium
- ② WASHER: steel
- ③ BUFFER: rubber
- ④ ADJUSTABLE STRIKER PLATE: Zinc-plated steel
- ⑤ BASE: brass
- ⑥ PISTON: brass
- ⑦ MAGNET: Plastoferrite
- ⑧ CYLINDER BODY: anodized aluminium
- ⑨ STATIC O-RINGS: NBR
- ⑩ BUSH: ball bearing
- ⑪ SCREW: pneumatically powered
- ⑫ PISTON ROD: grinded chromed stainless steel
- ⑬ PISTON ROD: tempered chrome stainless steel, grinded

VERSIONS:

- A With sliding bush
- B With ball bearing bush

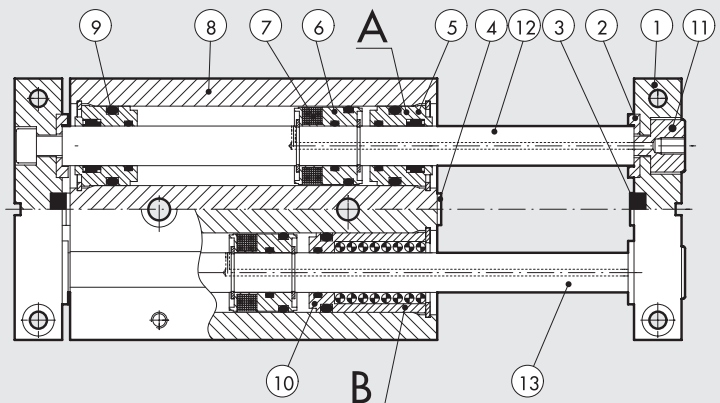

DIMENSIONS OF TWIN-CYLINDER SLIDE SERIES S12, ON BUSHES Ø 16 to 30

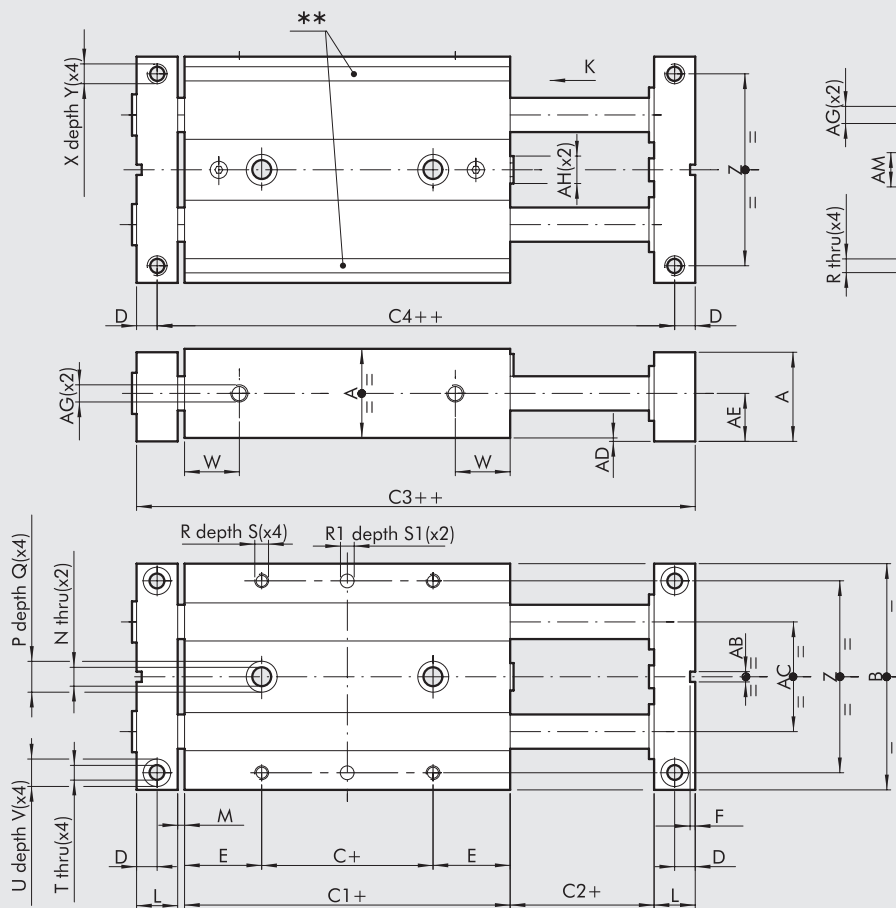

VIEW FROM "K"

Ø16 ** = Ø 20,25,30

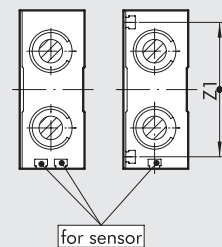

+ = ADD THE STROKE
 ++ = ADD TWICE THE STROKE

Code	Ø	A	B	C	C1	C2	C3	C4	D	E	F	G	H	L	M	N	P	Q	R	R1 ^{H7}	S	S1	T
W1460162...	16	22	56	10	50	2	74	64	5	20	1.5	11	12	10	2	4.3	8	4	M4	4	6	3	4.3
W1460202...	20	26	66	10	55	2	83	71	6	22.5	1.5	13	14	12	2	5.5	9	5	M4	4	7	3	4.3
W1460252...	25	32	78	10	60	2	92	78	7	25	2.5	16	17	14	2	6.5	10.5	6	M5	4	7	3	5.2
W1460302...	30	36	98	10	70	2	106	90	8	30	2.5	18	19	16	2	8.5	14	8	M6	6	8	5	5.2

Ø	U	V	W	X	Y	Z	Z1	AB	AC	AD	AE	AF	AG	AH	AM	AL
16	8	4	15	M5	8	46	-	3	26	1	12	5	M5	M6	M10x1	8.5
20	8	4	16	M5	10	56	54	3	30	1	14	5	M5	M8	M10x1	9
25	9	5	19	M6	12	66	64	5	39	1	17	6	M5	M10	M12x1	10
30	9	5	21	M6	12	86	82	5	52	1	19	6	G 1/8	M12	M14x1.5	12

...Enter the stroke in mm (e.g. Ø 16 stroke 50 = W1450162050)

Strokes for bore 16 mm 25; 50; 75; 100

Strokes for bore 20 mm 25; 50; 75; 100; 125

Strokes for bore 25 mm 25; 50; 75; 100; 125; 150

Strokes for bore 30 mm 25; 50; 75; 100; 125; 150

DIMENSIONS OF TWIN-CYLINDER SLIDE SERIES S12, ON BALL BEARINGS Ø 16 to 30

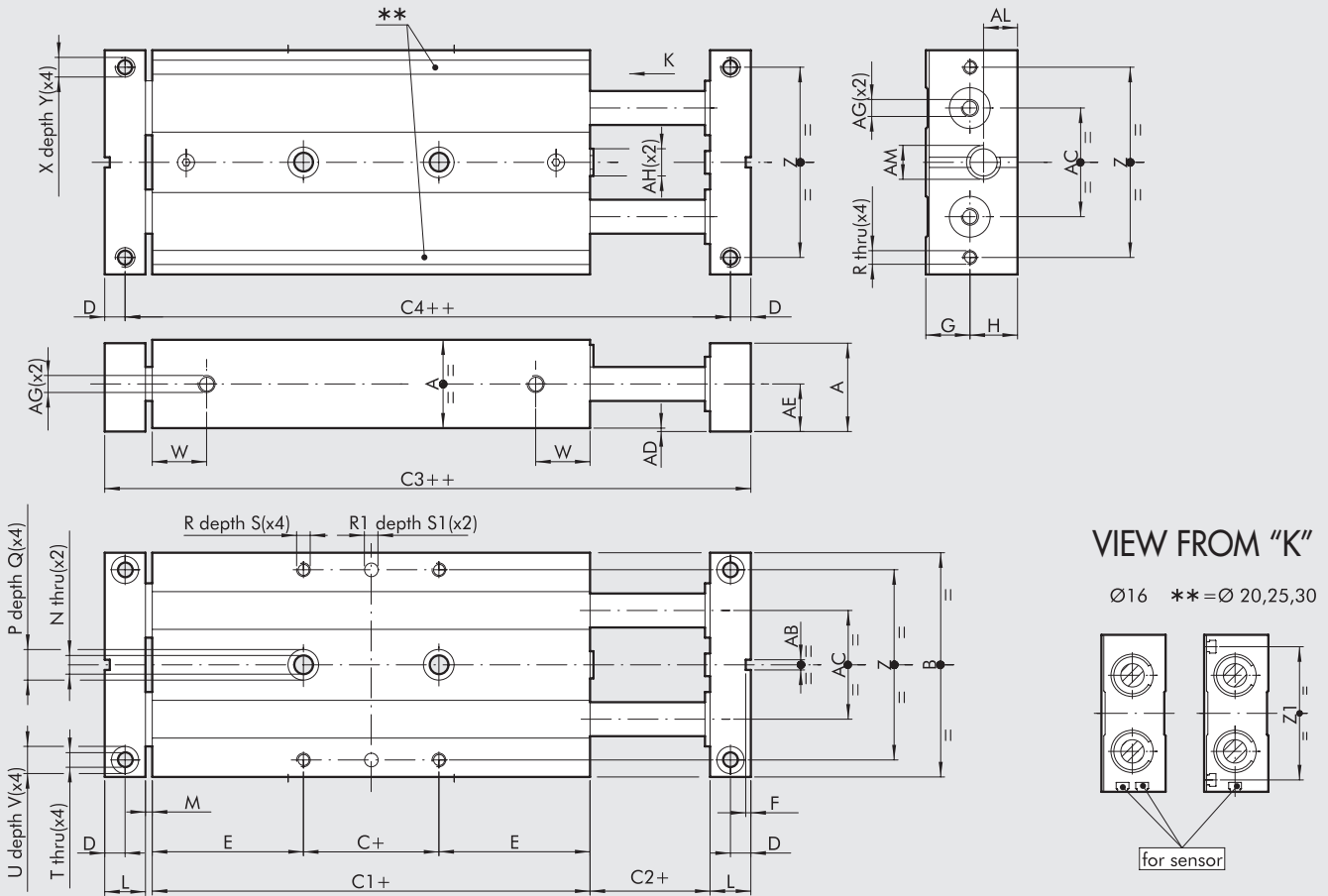

+ = ADD THE STROKE
 ++ = ADD TWICE THE STROKE

Code	Ø	A	B	C	C1	C2	C3	C4	D	E	F	G	H	L	M	N	P	Q	R	R1 ^{H7}	S	S1	T
W1460163...	16	22	56	10	85	2	109	99	5	37.5	1.5	11	12	10	2	4.3	8	4	M4	4	6	3	4.3
W1460203...	20	26	66	10	99	2	127	115	6	44.5	1.5	13	14	12	2	5.5	9	5	M4	4	7	3	4.3
W1460253...	25	32	78	10	105	2	137	123	7	47.5	2.5	16	17	14	2	6.5	10.5	6	M5	4	7	3	5.2
W1460303...	30	36	98	10	128	2	164	148	8	59	2.5	18	19	16	2	8.5	14	8	M6	6	8	5	5.2

Ø	U	V	W	X	Y	Z	Z1	AB	AC	AD	AE	AF	AG	AH	AM	AL
16	8	4	33	M5	8	46	-	3	26	1	12	5	M5	M6	M10x1	8.5
20	8	4	40	M5	10	56	54	3	30	1	14	5	M5	M8	M10x1	9
25	9	5	42	M6	6	66	64	5	39	1	17	6	M5	M10	M12x1	10
30	9	5	50	M6	12	86	82	5	52	1	19	6	G 1/8	M12	M14x1.5	12

...Enter the stroke in mm (e.g. Ø 16 stroke 50 = W1450163050)
 Strokes for bore 16 mm 25; 50; 75; 100
 Strokes for bore 20 mm 25; 50; 75; 100; 125
 Strokes for bore 25 mm 25; 50; 75; 100; 125; 150
 Strokes for bore 30 mm 25; 50; 75; 100; 125; 150

DIMENSIONS OF TWIN-CYLINDER SLIDE WITH SHOCK ABSORBERS SERIES S12, ON BUSHES Ø 16 to 30

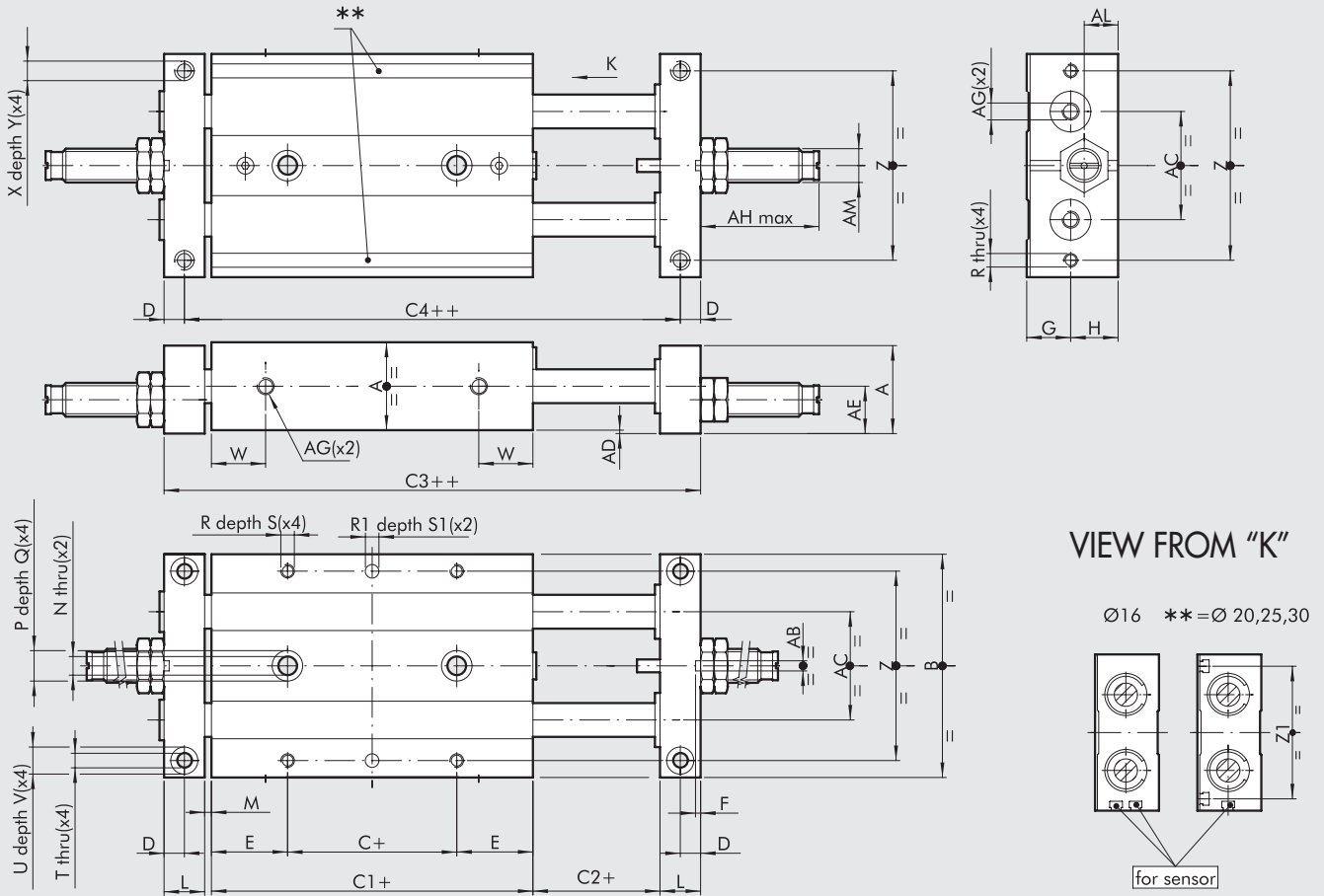

+ = ADD THE STROKE
 ++ = ADD TWICE THE STROKE

Code	Ø	A	B	C	C1	C2	C3	C4	D	E	F	G	H	L	M	N	P	Q	R	R1 ^{H7}	S	S1	T
W1460164...	16	22	56	10	50	2	74	64	5	20	1.5	11	12	10	2	4.3	8	4	M4	4	6	3	4.3
W1460204...	20	26	66	10	55	2	83	71	6	22.5	1.5	13	14	12	2	5.5	9	5	M4	4	7	3	4.3
W1460254...	25	32	78	10	60	2	92	78	7	25	2.5	16	17	14	2	6.5	10.5	6	M5	4	7	3	5.2
W1460304...	30	36	98	10	70	2	106	90	8	30	2.5	18	19	16	2	8.5	14	8	M6	6	8	5	5.2

Ø	U	V	W	X	Y	Z	Z1	AB	AC	AD	AE	AF	AG	AH	AM	AL
16	8	4	15	M5	8	46	-	3	26	1	12	5	M5	35	M10x1	8.5
20	8	4	16	M5	10	56	54	3	30	1	14	5	M5	35	M10x1	9
25	9	5	19	M6	12	66	64	5	39	1	17	6	M5	36	M12x1	10
30	9	5	21	M6	12	86	82	5	52	1	19	6	G 1/8	60	M14x1.5	12

...Enter the stroke in mm (e.g. Ø 16 stroke 50 = W1450164050)

- Strokes for bore 16 mm 25; 50; 75; 100
- Strokes for bore 20 mm 25; 50; 75; 100; 125
- Strokes for bore 25 mm 25; 50; 75; 100; 125; 150
- Strokes for bore 30 mm 25; 50; 75; 100; 125; 150

DIMENSIONS OF TWIN-CYLINDER SLIDE WITH SHOCK ABSORBERS SERIES S12, ON BALL BEARING Ø 16 to 30

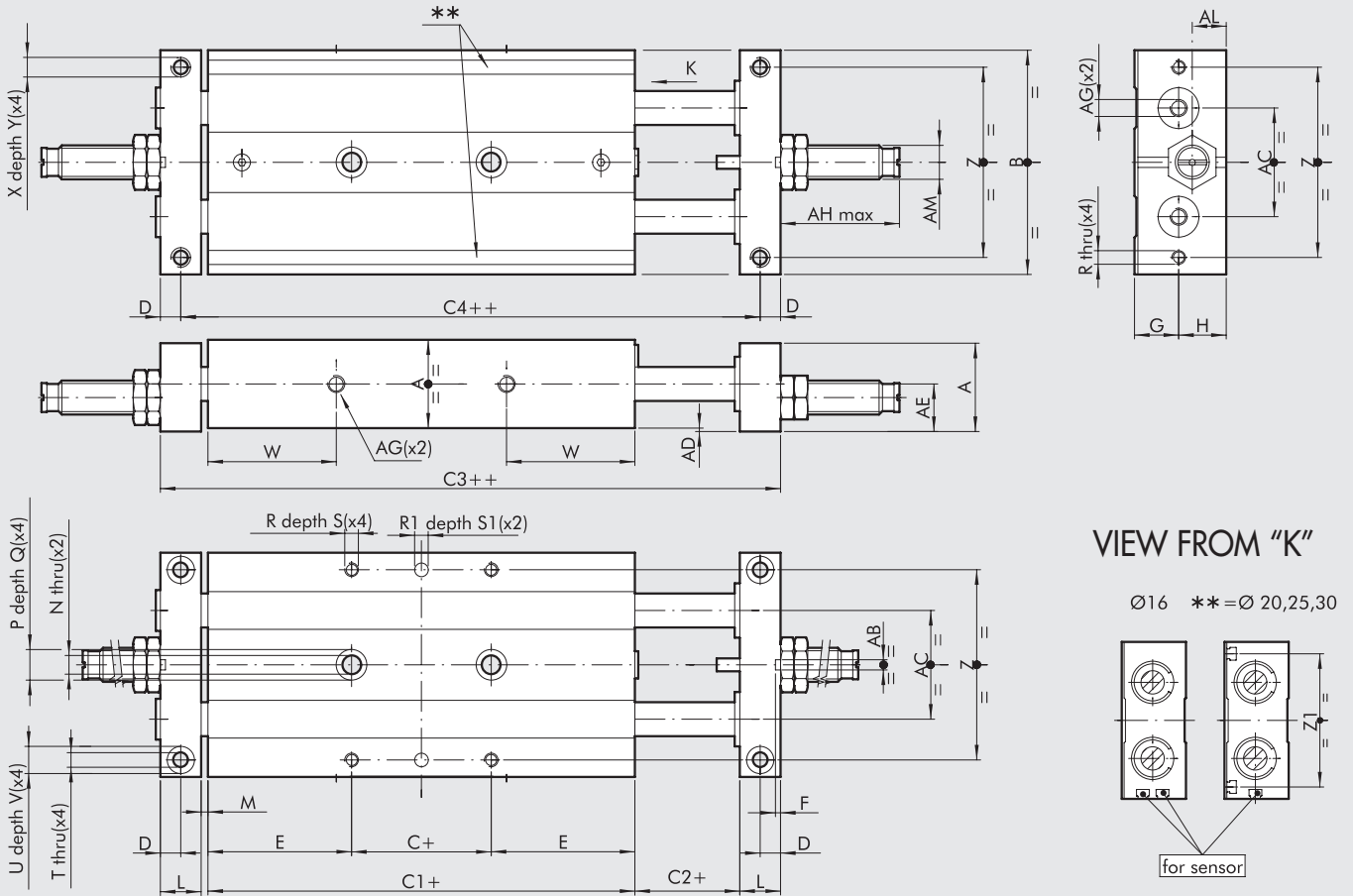

+ = ADD THE STROKE
 ++ = ADD TWICE THE STROKE

Code	Ø	A	B	C	C1	C2	C3	C4	D	E	F	G	H	L	M	N	P	Q	R	R1 ^{H7}	S	S1	T
W1460165...	16	22	56	10	85	2	109	99	5	37.5	1.5	11	12	10	2	4.3	8	4	M4	4	6	3	4.3
W1460205...	20	26	66	10	99	2	127	115	6	44.5	1.5	13	14	12	2	5.5	9	5	M4	4	7	3	4.3
W1460255...	25	32	78	10	105	2	137	123	7	47.5	2.5	16	17	14	2	6.5	10.5	6	M5	4	7	3	5.2
W1460305...	30	36	98	10	128	2	164	148	8	59	2.5	18	19	16	2	8.5	14	8	M6	6	8	5	5.2

Ø	U	V	W	X	Y	Z	Z1	AB	AC	AD	AE	AF	AG	AH	AM	AL
16	8	4	33	M5	8	46	-	3	26	1	12	5	M5	35	M10x1	8.5
20	8	4	40	M5	10	56	54	3	30	1	14	5	M5	35	M10x1	9
25	9	5	42	M6	6	66	64	5	39	1	17	6	M5	36	M12x1	10
30	9	5	50	M6	12	86	82	5	52	1	19	6	G 1/8	60	M14x1	12

...Enter the stroke in mm (e.g. Ø 16 stroke 50 = W1450165050)
 Strokes for bore 16 mm 25; 50; 75; 100
 Strokes for bore 20 mm 25; 50; 75; 100; 125
 Strokes for bore 25 mm 25; 50; 75; 100; 125; 150
 Strokes for bore 30 mm 25; 50; 75; 100; 125; 150

ACCESSORIES

RETRACTABLE SENSOR

SENSOR, SQUARE TYPE

Latest generation,
secure fixing

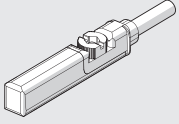

SENSOR, OVAL TYPE

Traditional

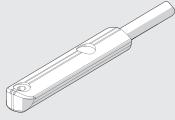

For codes and technical data, see chapter A6.

SPARES

SHOCK ABSORBERS

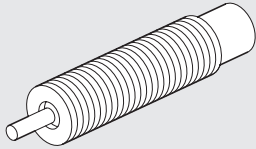

Code	Ø	Description
0950004002	16 - 20	Shock absorbers ECO 10 MF2 + nut M10x1
0950004003	25	Shock absorbers ECO 15 MF1 + nut M12x1
0950004004	30	Shock absorbers ECO 25 MC2 + nut M14x1.5

NOTES