

**DESCRIPTION**

Solenoid pilot 2 way normally closed. Tube Ø10 flange fixing.

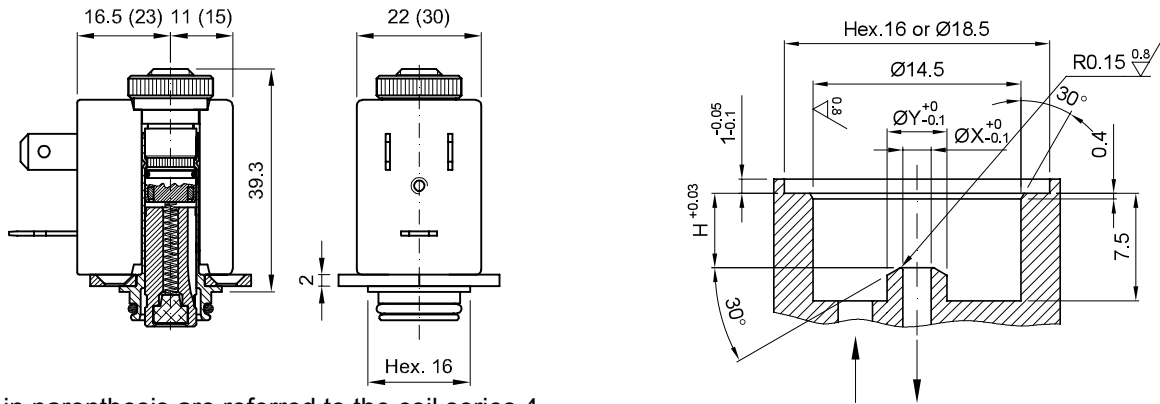

The quote in parenthesis are referred to the coil series 4

CODE		ØX mm	ØY mm	H mm	Differential pressure bar			Nominal power			Coil		Seal ①	Temp. range °C
Brass Tube	S.Steel Tube				Min	Max		AC Inrush	VA Holding	DC Watt	Series	Width		
E570...	E572...	1.2	4.2	5	0	25	25	12	8	6.5	3	22	NBR=B	-10 +90
		1.5	4.2	5.1	0	16	16							
		2	4.2	5.2	0	12	10							
		2.5	4.2	5.4	0	8	5.5							
E570...40	E572...40	4	5.8	5.6	0	4	1.5	15	11	5	4	30	EPDM=E	-10 +140
E570...	E572...	2	4.2	5.2	0	25	15							
		2.5	4.2	5.4	0	16	8							
		3.1	4.2	5.5	0	8	4							
E570...40	E572...40	4	5.8	5.6	0	5	2.5							

**DESCRIPTION**

Solenoid pilot 2 way normally open. Tube Ø10 flange fixing.

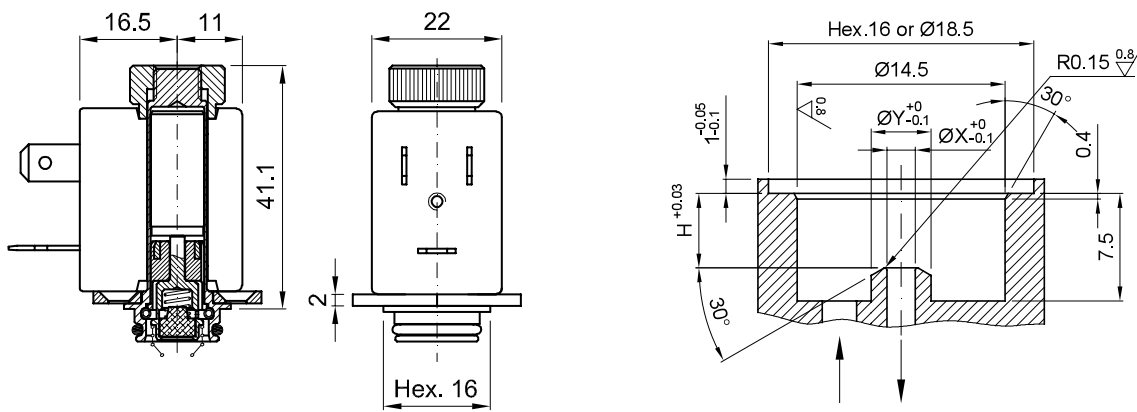

**7**

CODE		ØX mm	ØY mm	H mm	Differential pressure bar			Nominal power			Coil		Seal ①	Temp. range °C
Brass Tube	S.Steel Tube				Min	Max		AC Inrush	VA Holding	DC Watt	Series	Width		
E575...		1.2	4.2	5	0	19	19	12	8	6.5	3	22	NBR=B	-10 +90
		1.5	4.2	5.1	0	14	14							
		2	4.2	5.2	0	8	8							
		2.5	4.2	5.4	0	4.5	4.5							
		3.1	4.2	5.5	0	2.5	2.5							

**DESCRIPTION**

Solenoid pilot 3 way normally closed. Tube Ø10 flange fixing.

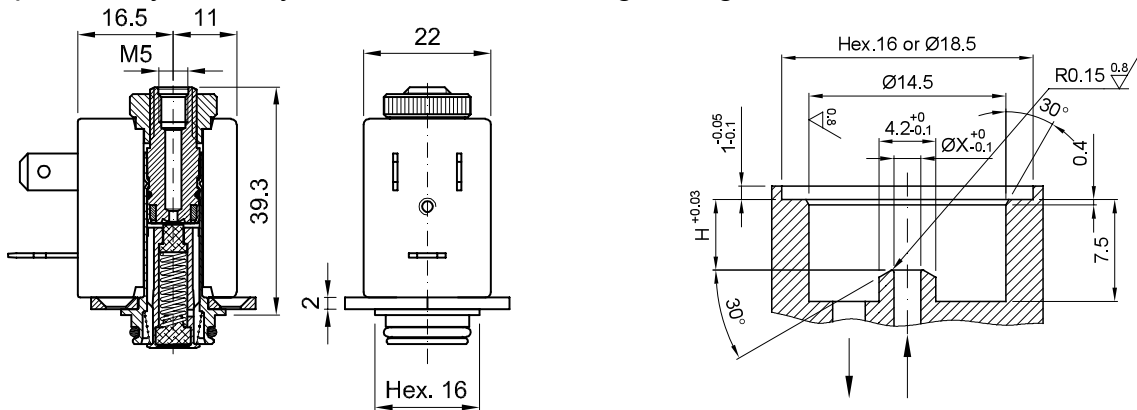

CODE		ØX mm	Øexh. mm	H mm	Differential pressure bar			Nominal power			Coil		Seal ①	Temp. range °C
Brass Tube	S.Steel Tube				Min	Max		AC Inrush	VA Holding	DC Watt	Series	Width		
E580...	E582...	1.2	1.5	5	0	15	15	12	8	6.5	3	22	NBR=B EPDM=E FPM=V	-10 +90 -10 +140 -10 +140
		1.5	1.5	5.1	0	10	10							
		2	1.7	5.2	0	6	6							

**DESCRIPTION**

Solenoid pilot 3 way normally open. Tube Ø10 flange fixing.

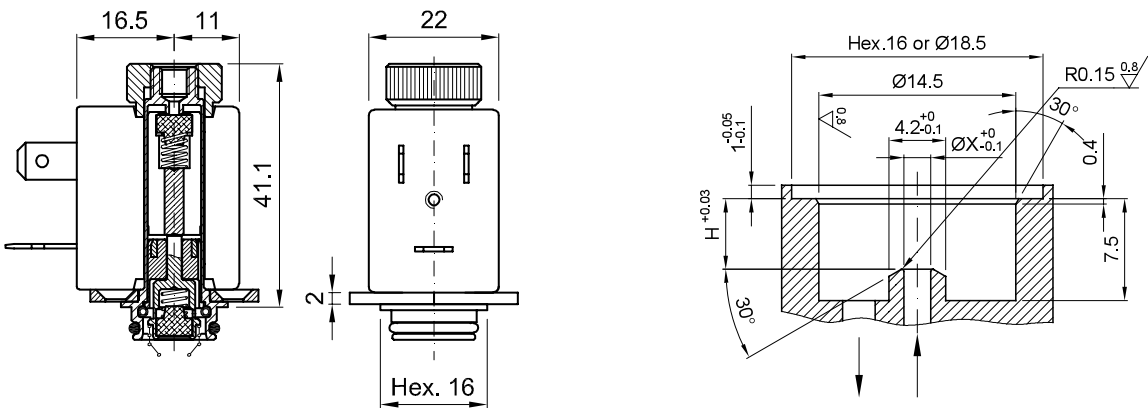

CODE		ØX mm	Øexh. mm	H mm	Differential pressure bar			Nominal power			Coil		Seal ①	Temp. range °C
Brass Tube	S.Steel Tube				Min	Max		AC Inrush	VA Holding	DC Watt	Series	Width		
E585...		1.2	1.5	5	0	12	8	12	8	6.5	3	22	NBR=B EPDM=E FPM=V	-10 +90 -10 +140 -10 +140
		1.5	1.5	5.1	0	9	6							