

DESCRIPTION

Solenoid valve 2 way direct acting poppet type.
 Bi-stable impulse drive.
 The bi-stable function is achieved by the use of a polarized permanent magnet energizing the coil with a DC current for at least 15ms in the reverse direction of the preceding impulse.



2

CONSTRUCTION

Body	Brass
Armature tube	Brass
Plunger and core	AISI 430FR
Magnet	NeFeB
Springs	AISI 302
Seal material	NBR - FPM - EPDM

FEATURES

Maximum allowable pressure PS 50bar
 Maximum fluid viscosity 25cSt (mm²/s)
 Ambient temperature: from -10°C to +80°C according to the coil
 Universal mounting position

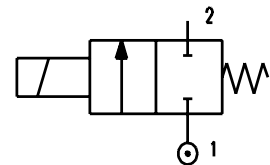

- OPTIONS:** Stainless steel armature tube
 Electroless nickel plating
 Series 7 explosion proof coil according to ATEX - EExmII
 Special powers

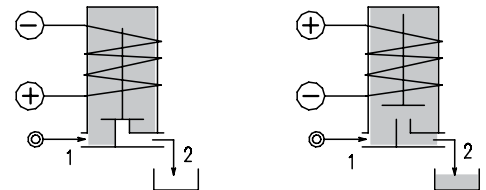

CODE ① ②	Connection G ISO 228	Orifice mm	Kv m ³ /h	Differential pressure bar		Nominal power DC Watt	Coil		Seal ①	Temp. range °C
				Min	Max		Series	Width		
D115A...12///...	1/8"	1.2	0.04	0	12	2	3	22	NBR=B	-10 +90
D115A...15///...	1/8"	1.5	0.06	0	8	2				
		1.5	0.06	0	20	5				
D115A...20///...	1/8"	2	0.09	0	3	2				
		2	0.09	0	12	5				
D115A...25///...	1/8"	2.5	0.14	0	1	2				
		2.5	0.14	0	5	5				
		2.5	0.14	0	8	6.5				
D115A...31///...	1/8"	3.1	0.19	0	2	5				
		3.1	0.19	0	3.5	6.5				

- ① Seal
 ② Coil

Example: D115AB20///300120 NBR seal
 Coil 12V DC 2W

COILS ②	Direct Current															Electrical connection	Connectors
	3V			6V			9V			12V			24V				
	2W	5W	6.5W	2W	5W	6.5W	2W	5W	6.5W	2W	5W	6.5W	2W	5W	6.5W		
Series 2 Width 30	308120			305120	305150		307120	307150		300120	300150	300	301120	301150	301	DIN 46244	PG9 code 10348000

DESCRIPTION
 Class F insulation
 Voltage tolerance $\pm 10\%$
 Protection class
 IP65 with connector fitted
 IP00 without connector
 Continuous service ED100%

OPTIONS
 Class H insulation
 Cable attached
 Special coil voltage
 Special coil powers

(for coil details see section 8)

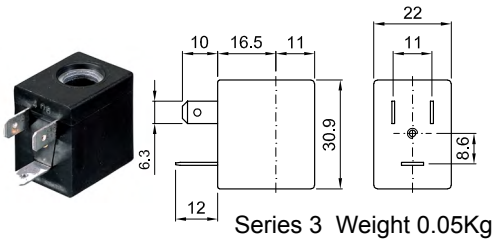

SPARE PARTS LIST

1. Coil fixing nut
2. Coil
3. Plunger
4. Armature tube assembly

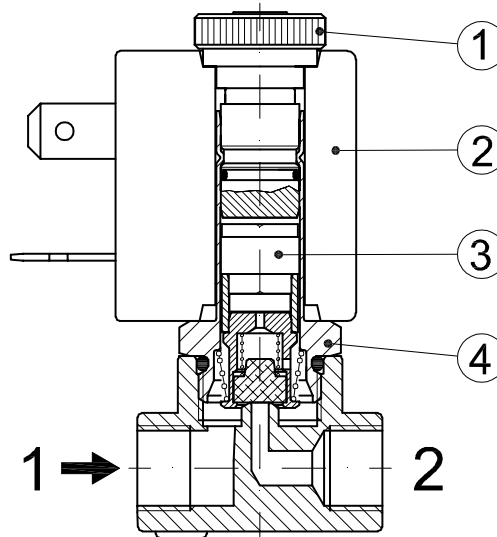

OVERALL DIMENSION

