

**DESCRIPTION**

Solenoid valve in line normally closed direct acting poppet type.

**CONSTRUCTION**

Body/Armature tube	AISI 303
Plunger and core	AISI 430FR
Springs	AISI 302
Seal material	NBR - FPM - EPDM



**FEATURES**

Maximum allowable pressure 80bar  
 Maximum fluid viscosity 25cSt (mm<sup>2</sup>/s)  
 Ambient temperature: from -10°C to +80°C according to the coil  
 Universal mounting position

**OPTIONS:** Mounting bracket  
 Versions for use with industrial oxygen  
 Special coil powers  
 c us certified coils

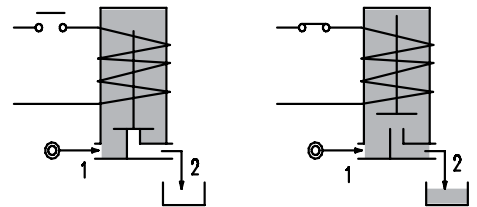
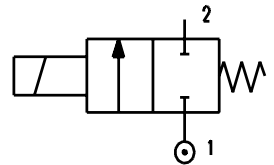

2

**CONFIGURATIONS**

G1/8" M / Push-on for pipes Ø6x4	G1/8" M - G1/8" F	G1/8" F / Push-on for pipes Ø6x4	G1/8" F - G1/8" F	Push-on/Push-on for pipes Ø6x4	Push-on/Push-on for pipes Ø6x4 with check valve	G1/4" M - G1/4" F
NW	NA	AW	AA	WW	WW... /2	TB

CODE ① ② ③	Orifice mm	Kv m <sup>3</sup> /h	Differential pressure bar			Electrical data		Coil		Seal ②	Temperature range °C
			Min	Max		Voltage (V)	Power	Series	Width		
D130... ..10/...	1	0.03	0	-	8.5	12-24V DC	2 W	3	22	NBR=B	-10 +90
D130... ..12/...	1.2	0.04	0	-	6						
D130... ..15/...	1.5	0.06	0	-	4						
E130... ..10/...	1	0.03	0	50	-	230V 50/60Hz	3.5 VA	3	22	FPM=V	-10 +140
E130... ..12/...	1.2	0.04	0	40	-						
E130... ..15/...	1.5	0.06	0	25	-						
E130... ..10/...	1	0.03	0	50	50	All standard voltages	6.5W or 8VA	3	22	EPDM=E	-10 +140
E130... ..12/...	1.2	0.04	0	50	50						
E130... ..15/...	1.5	0.06	0	50	50						

- ① Configurations Example: E130NWB10///301 - G1/8" male - Push-on connections
- ② Seal NBR seals - 24V DC 6.5W
- ③ Coil

COILS ③	Alternating Current 50/60Hz (V)							Direct Current (V)			Electrical connection	Connectors
	12	24	48	110	220 230	240	380	12	24	48		
Series 3 Width 22 6.5W or 8VA	30A	30B	30C	30D	30E	30F	30G	300	301	302	DIN 46244	PG9 CODE 10348000
c		U35B		c		U35D		c	U35F			

**DESCRIPTION**  
 Class F insulation  
 Voltage tolerance  
 AC +15% -10%  
 DC ± 10%  
 Protection class  
 IP65 with connector fitted  
 IP00 without connector  
 Continuous service ED100%

COILS ③	Alternating Current 50/60Hz (V)	Direct Current (V)		Electrical connection	Connectors
	220-230	12	24		
Series 3 Width 22 2W or 3.5VA	30E1P	300120	301120	DIN 46244	PG9 CODE 10348000

**OPTIONS**  
 Class H insulation  
 Cable attached  
 Special coil voltage  
 Special coil powers  
 c certified coils

(for coil details see section 8)

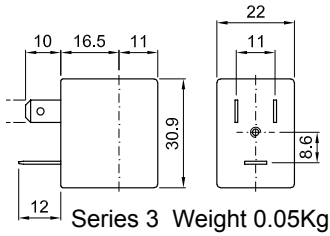

### SPARE PARTS LIST

- OR
- Coil

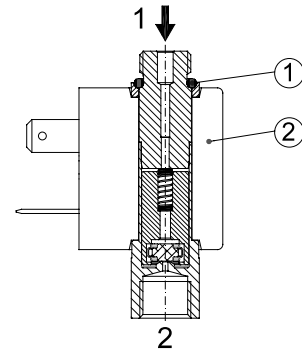

### OVERALL DIMENSIONS

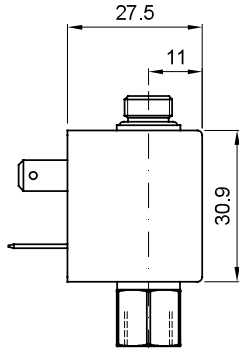

### CONNECTION NA

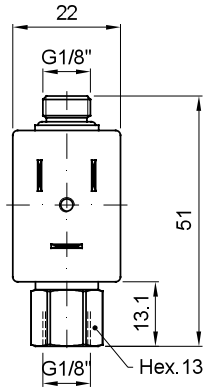

### CONNECTION AA

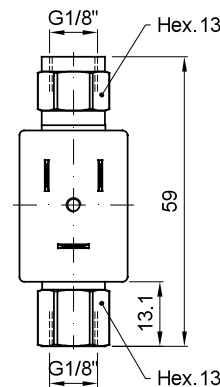

### CONNECTION NW

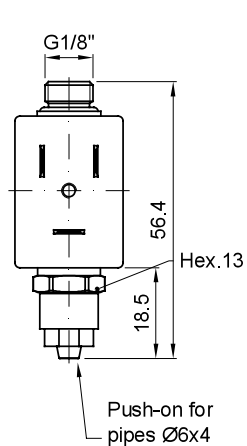

### CONNECTION AW

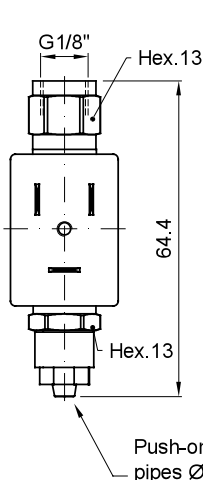

### CONNECTION WW

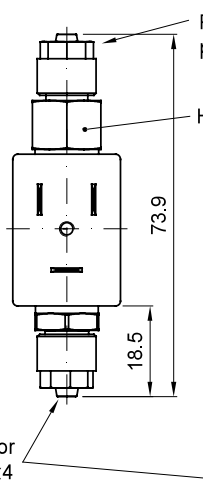

### CONNECTION WW WITH CHECK VALVE

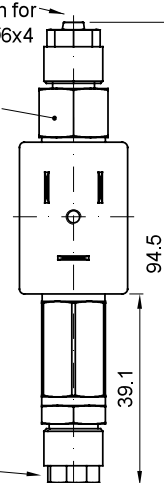

### CONNECTION TB

