

ROTOLINEAR SWING CLAMP CYLINDERS SERIES SWC AND SWH

When retracting, the piston rod of rotolinear swing clamp cylinders first rotates by 90° and then moves straight forward. When exiting, the sequence is reversed.

This facilitates the positioning of the workpiece to be clamped.

You can choose either a clockwise or an anti-clockwise direction.

A version without rotation is also available. The mechanism is very simple. It consists of a spiral groove and a pin that fits into the groove.

The fixing bracket, which can be ordered as an accessory, can be freely orientated through 360° and locked to the piston rod.

Two series are available:

- Series SWC (SWing Compact), which has the same fixings as CMPC series compact cylinders and can use the same flange and feet as the CMPC
- Series SWH (Swing Heavy Duty), which is more sturdy and features an enlarged body and piston rod guide system.

Possibility of choosing between polyurethane or FKM/FPM gaskets (for high temperatures).



TECHNICAL DATA		SWC					SWH			
Bore	mm	16	25	32	40	50	40	50	63	
Operating pressure	bar	2 to 10								
	MPa	0.2 to 1								
	psi	29 to 145								
Temperature range	Polyurethane FKM/FPM	-20 to +80								
		-10 to +150								
Fluid		Unlubricated air; lubrication, if used, must be continuous.								
Design		Linear and rotating movement by means of a cam integral to the piston					Linear and rotating movement by means of a cam in the rod guide bushing			
Clamping stroke (linear)	mm	10	10	10	10	20	10	25	8	
Overall Stroke	mm	20	25	25	27.3	40	25	43	25	
Direction of rotation		Right or left or straight								
Rotation angle	degrees	90° ± 4°								
Sensor magnet		Yes								
Theoretical clamping force at 6 bar	N	90	220	360	630	970	630	970	1650	
Effective clamping force at 6 bar, in relation to the distance of the clamping point from the cylinder axis	Locking force	N	80	180	300	450	810	420	800	1200
	Distance	mm	27	35	50	50	65	70	80	90
Weights	g	190	432	599	962	1577	1497	2895	2960	

COMPONENTS SERIES SWC

- PISTON ROD: grinded chromed steel
- HEAD: extruded anodized aluminium alloy
- BARREL: extruded aluminium, anodized
- PISTON GASKET: polyurethane or FKM/FPM
- MAGNET: neodymium-plastic
- PISTON ROD GASKET: polyurethane or FKM/FPM
- GUIDE BUSHING: steel strip with bronze and PTFE insert
- STATIC O-RINGS: NBR
- SECURING SCREWS: zinc-plated steel
- PIN: hardened steel
- CAM: Ø 16 steel - Ø 25 to 50 technopolymer
- BRACKET: anodized aluminium
- BRACKET PLUG: zinc-plated steel and technopolymer

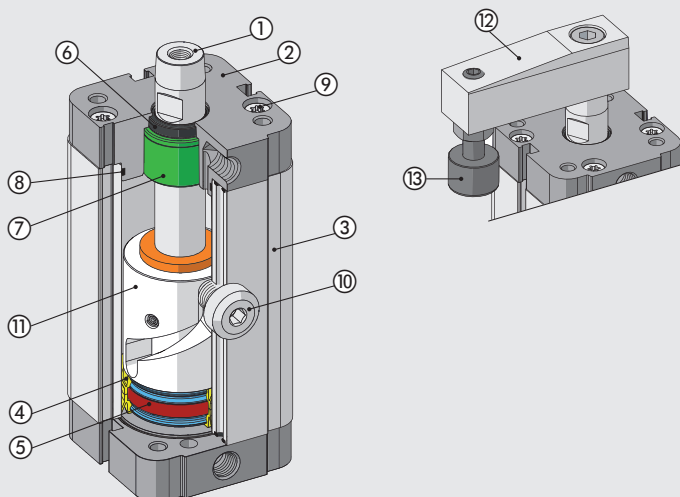

COMPONENTS SERIES SWH

- ① SPISTON ROD: grinded chromed steel
- ② BODY: anodized aluminium
- ③ PISTON ROD GASKET: polyurethane or FKM/FPM
- ④ SCRAPER GASKET: polyurethane or FKM/FPM
- ⑤ HEADER FOR GUIDE AND PISTON ROD ROTATION: technopolymer
- ⑥ PIN: hardened steel
- ⑦ PISTON: aluminium
- ⑧ PISTON GASKET: polyurethane or FKM/FPM
- ⑨ MAGNET: plasteodymium or plastoferrite
- ⑩ STATIC O-RINGS: NBR
- ⑪ SECURING SCREWS: zinc-plated steel
- ⑫ ADAPTOR: anodized aluminium

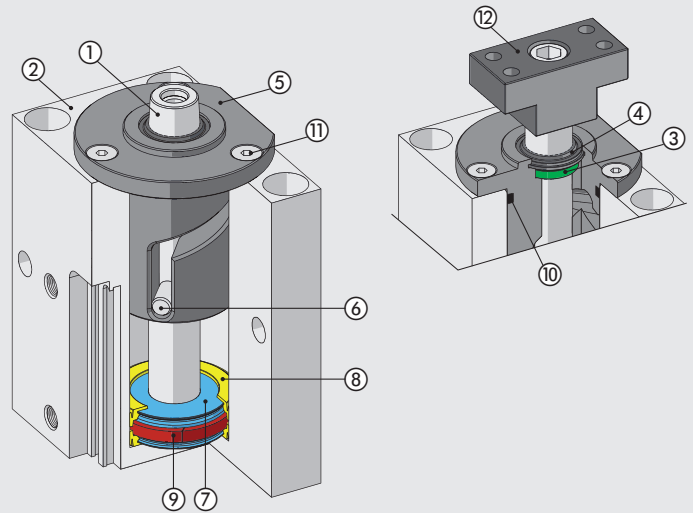

BRACKET FIXING

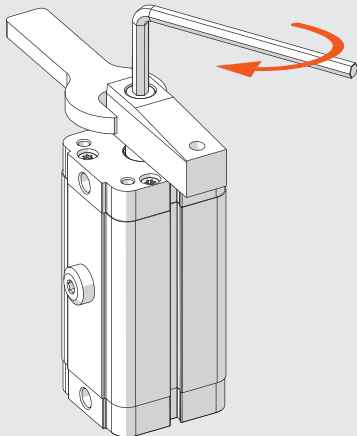

Series SWC

Ø	Maximum tightening torque [Nm]
16	3
25	12
32	24
40	24
50	40

Series SWH

Ø	Maximum tightening torque [Nm]
40	24
50	40
63	40

N.B.: When tightening or loosening the screw, DO NOT hold the cylinder body, only hold the bracket in place using a spanner.

DIRECTION OF ROTATION

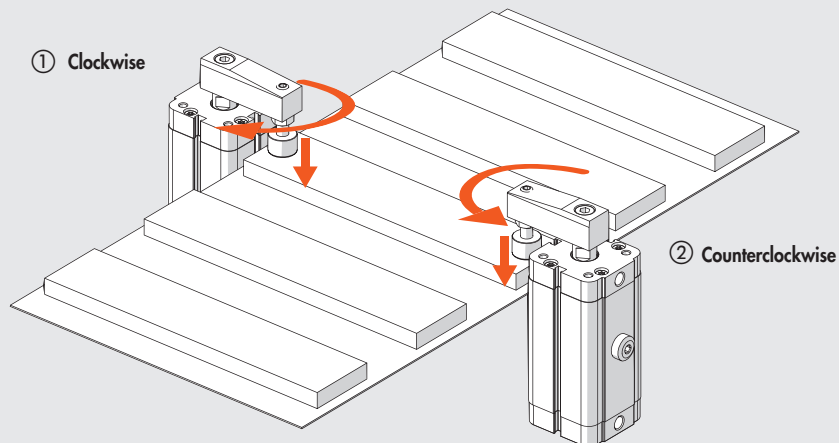

The right or left direction of rotation is determined by looking at the cylinder from the piston rod side, when the rod retracts:

- ① Right (R) = clockwise
- ② Left (L) = counterclockwise

MAXIMUM PERMISSIBLE MOMENT OF INERTIA

The permissible moment of inertia depends on the speed of movement. Refer to the formula below to calculate the moment of inertia.

$$J = \frac{M1 \cdot L1^2}{4} + M2 \cdot L2^2$$

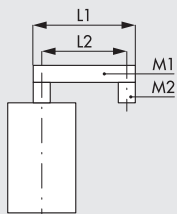

- M1 = Mass of the lever arm [kg]
- M2 = Mass of the screw and plug [kg]
- L1 = Lever arm length [cm]
- L2 = Distance from the screw centre to the cylinder axis [cm]

- J = Moment of inertia [kg · cm²]
- t = Time to run each stroke

SWC 16

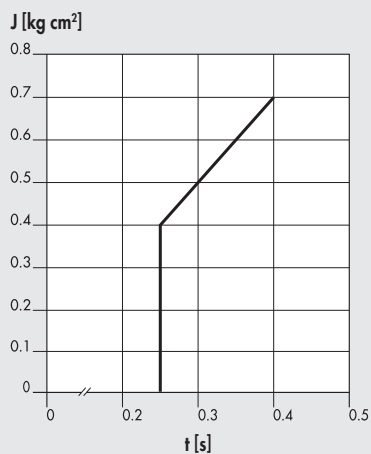

SWC 25

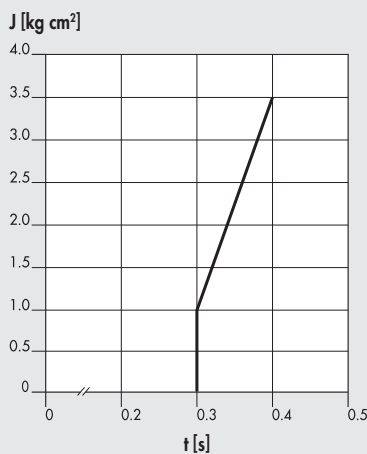

SWC 32

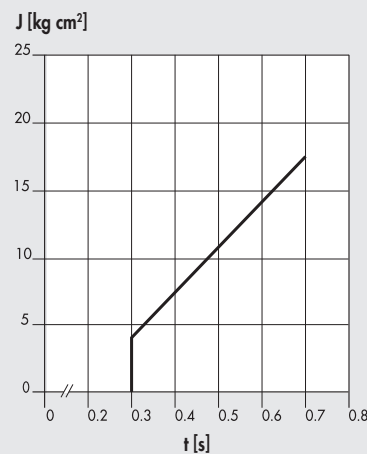

SWC 40

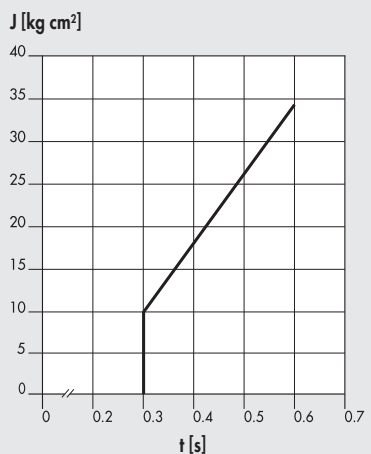

SWC 50

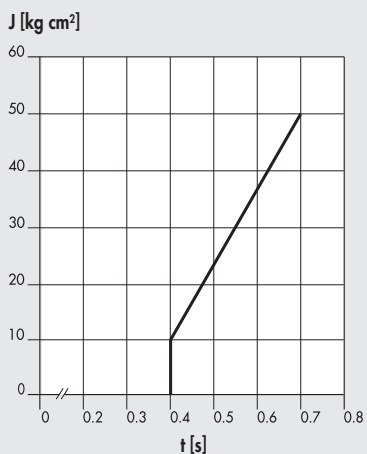

SWH 40

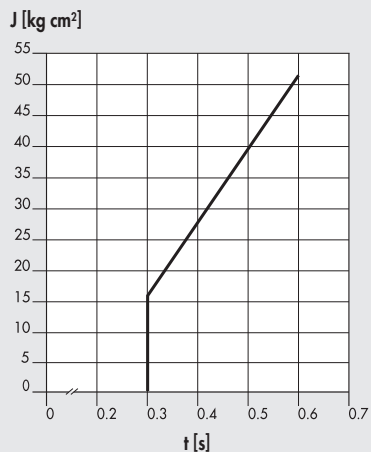

SWH 50

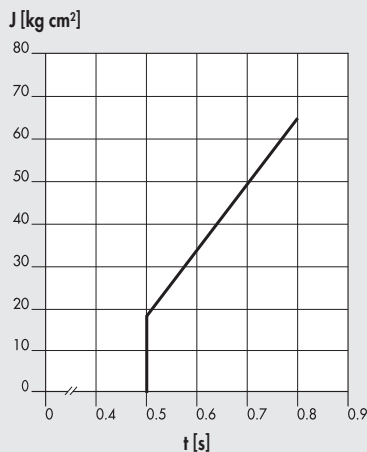

SWH 63

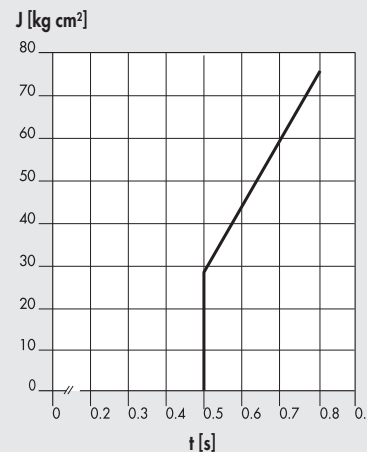

LOCKING FORCE

Locking force "F" as a function of the length "L" of the bracket and pressure, measured at 5 mm from the limit switch.

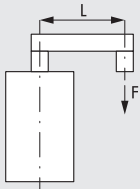

SWC 16

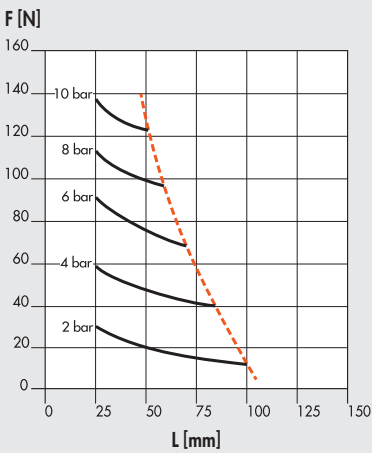

SWC 25

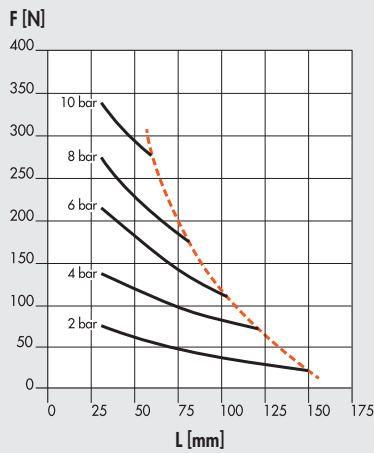

SWC 32

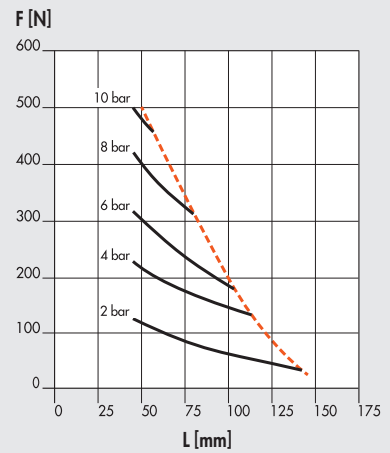

SWC 40

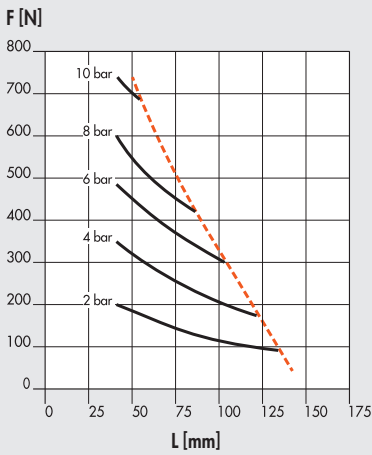

SWC 50

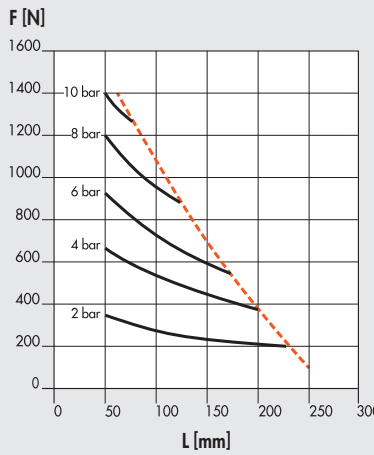

----- Maximum lever arm length

SWH 40

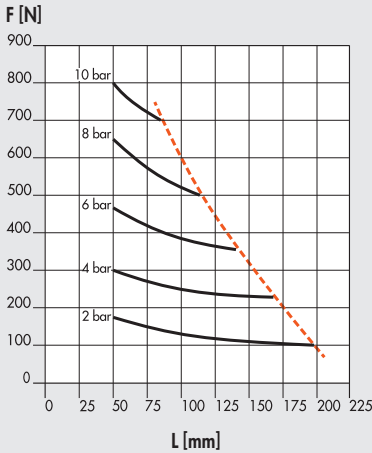

SWH 50

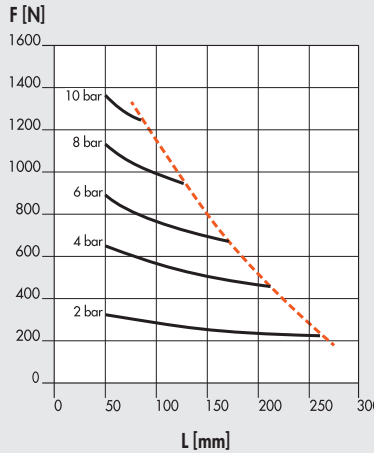

SWH 63

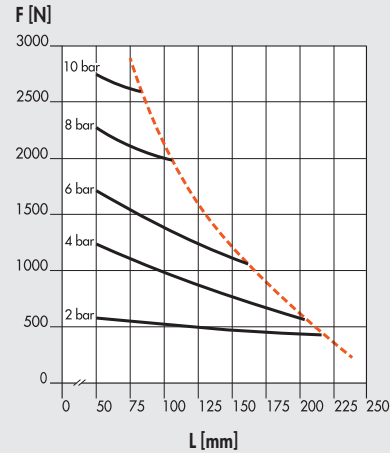

DIMENSIONS - SERIES SWC

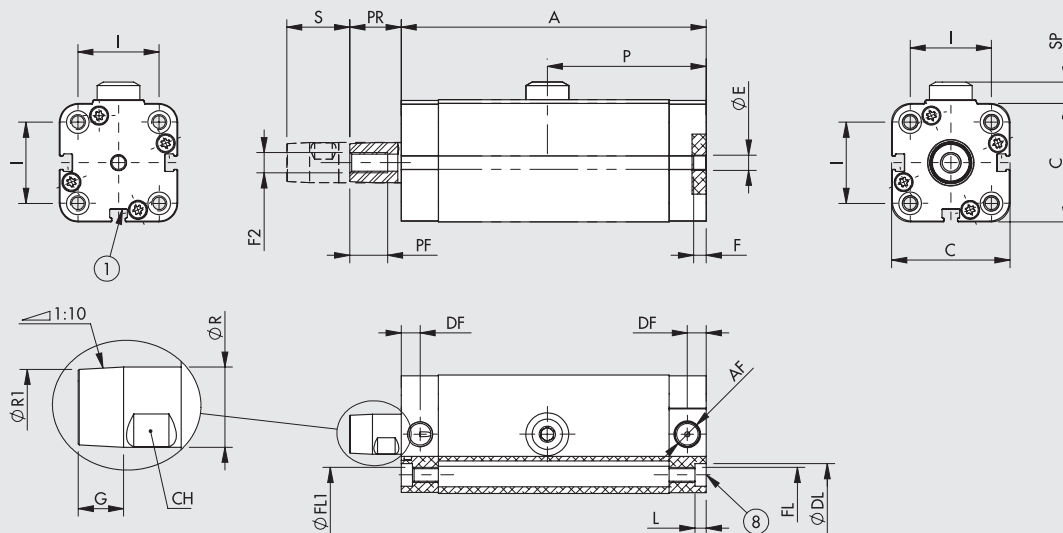
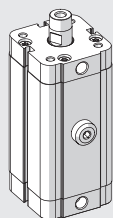

- 1 = SENSOR SLOT
- 8 = SEAT FOR DIN 7984 SCREWS (only Ø 32 - 50)

Overall Stroke																						
Ø	S	A	AF	C	CH	DF	ØDL*	ØE ^{H9}	F	F2	FL*	ØFL1	G	I*	L	P	PF	PR	ØR	ØR1	SP	Weight [g]
16	20	85	M5	29.4	7	4	6	6	5	M4	M4	3.2	5	18	3.2	31.5	13	11	8	7.5	4.8	190
25	25	102.5	M5	40.4	10	6	7.5	6	5	M6	M5	4.2	7.4	26	4.2	38.3	15	16.4	12	11.3	5.3	432
32	25	121	1/8"	47	13	7.5	9	6	5	M8	M6	5.2	9	32.3	4.5	63	15	20.4	16	15	8.5	599
40	27.3	122.5	1/8"	56	13	7.5	9	6	5	M8	M6	5.2	9	38	4.5	65	15	20.4	16	15	8.5	962
50	40	158	1/8"	67	17	7.5	10.7	6	5	M10	M8	6.2	10.3	46.5	5	85.3	15	20.8	20	19	9.5	1577

* For Ø 16, 25 according to UNITOP; for Ø 32 - 50 according to ISO

DIMENSIONS - SERIES SWH

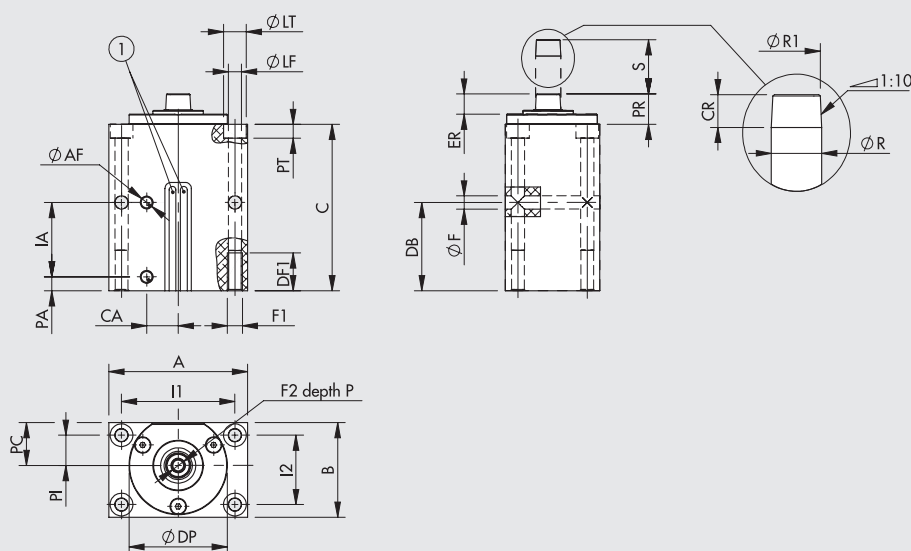
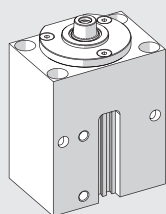

- 1 = SENSOR SLOT

Overall Stroke																												
Ø	S	A	ØAF	B	C	CA	CR	DB	DF1	ØDP	ER	ØF	F1	F2	I1	I2	IA	ØLF	LT	P	PA	PC	PI	PR	ØPT	ØR	ØR1	Weight [g]
40	25	90	1/8"	65	96	20	10	50	25	64	14	8.5	M10	M8	73	48	42	8.5	15	18	8	27.5	19	19	9	16	15	1497
50	43	110	1/8"	75	132	25	13	70	30	78	16	10.5	M12	M10	90	55	59	10.5	18	23	11	34	24	24	11	20	18.7	2895
63	25	120	1/4"	90	107.5	25	13	55	30	95	16	10.5	M12	M10	100	70	85	10.5	18	23	11	40	30	24	11	20	18.7	2960

KEY TO CODES

CYL	W149 SERIES	C VERSION	40 BORE	10 CLAMPING STROKE	R DIRECTION OF ROTATION	A EXECUTION	P GASKETS
W149	Swing clamp cylinders SW	C Compact	16	10	R Clockwise	A C45 chromed and ground piston rod, aluminium piston rod	P Polyurethane gaskets V FKM/FPM gaskets
			25	10	L Counter-clockwise		
			32	10	S Straight		
			40	10			
			50	20			
		H Heavy duty	40	10			
			50	25			
			63	08			

ACCESSORIES FOR CYLINDERS SERIES SWC

BRACKET

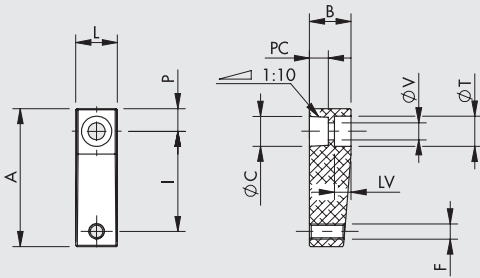

Code	Ø	A	L	I	P	C	PC	LV	V	B	T	F	Weight [g]
W0950166022	16	36.5	11	26.5	6	7.9	5	4.5	4.5	11	8	M4	10
W0950256022	25	50	16	35	9	11.9	7.5	6.5	6.5	16	11	M6	28
W0950326022	32-40	69	20	49	12	15.9	10.1	8.5	9	20	15	M8	65
W0950506022	50	88	25	65	13	19.9	10.5	7	11	25	18	M10	118

MATERIAL

Bracket: anodized aluminium
Screws TCE: zinc-plated steel

BRACKET PLUG

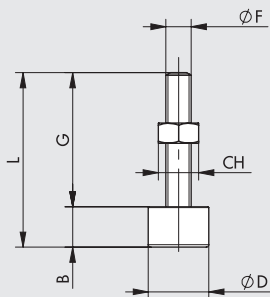

Code	Ø	L	B	G	F	CH	D	Weight [g]
W0950166023	16	32	6.5	25.5	M4	7	11	5
W0950256023	25	43	10	33	M6	10	15	11
W0950326023	32-40	49	13	36	M8	13	19	27
W0950506023	50	69	16	53	M10	16	24	58

MATERIAL

Plug: technopolymer
Screw and nut: zinc-plated steel
Note: if there is no risk of engraving the part to be clamped, the customer can use an hex an hexagonal-head screw available from the trade, instead of the coded pad.

FOOT - MODEL A

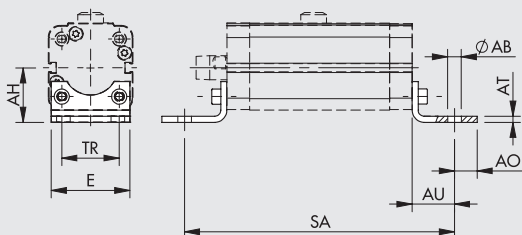

UNITOP

Code	Ø	Clamping stroke	E	TR	AU	AB	AH	SA	AT	AO	Weight [g]
W0950126001 ▲	16	10	30	18	13	5.5	22	111	3	4.5	26
W0950256001	25	10	40	26	16	6.6	30	134.5	4	6	52

ISO

Code	Ø	Clamping stroke	E	TR	AU	AB	AH	SA	AT	AO	Weight [g]
W0950322001	32	10	45	32	24	7	31.9	169	4	11	76
W0950402001	40	10	52	36	28	9	36	178.5	4	15	100
W0950502001	50	20	65	45	32	9	45	222	5	15	162

▲ Non UNITOP norm fixing distance
Note: Individually packed with 2 screws.

FLANGE - MODEL C

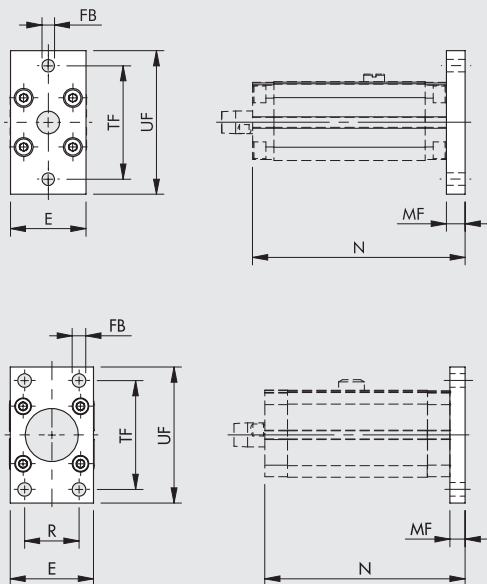

UNITOP

Code	Ø	Clamping stroke	E	UF	TF	FB	MF	N	Weight [g]
W0950126002 ▲	16	10	29	55	43	5.5	10	95	112
W0950256002	25	10	40	76	60	6.6	10	112.5	226

ISO

Code	Ø	Clamping stroke	E	UF	TF	R	FB	N	MF	Weight [g]
W0950322002	32	10	50	80	64	32	7	131	10	246
W0950402002	40	10	55	90	72	36	9	132.5	10	290
W0950502002	50	20	65	110	90	45	9	170	12	522

▲ Non UNITOP norm fixing distance
Note: Supplied with 4 screws.

ACCESSORIES FOR CYLINDERS SERIES SWH

ADAPTOR

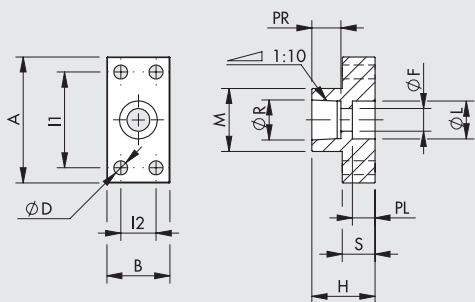

Code	Ø	A	B	L1	L2	D	H	M	S	L	F	PL	R	PR	Weight [g]
W0950406024	40	50	25	38	14	5.5	25	25	13	15	9	9	15.9	11.5	50
W0950506024	50	60	30	45	15	7	30	30	15	18	11	11	17.9	15	85
W0950636024	63	65	35	48	18	9	35	32	17	18	11	11	19.9	17	125

MATERIAL

Adaptor: anodized aluminium
Screws TCE: zinc-plated steel

ACCESSORIES FOR CYLINDERS SERIES SWC AND SWH: MAGNETIC SENSORS AND POSITION SENSORS

RETRACTABLE SENSOR

SENSOR, SQUARE TYPE
Latest generation,
secure fixing

SENSOR, OVAL TYPE
Traditional

For codes and technical data, see **chapter A6**.

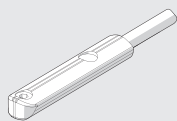
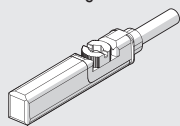

POSITION SENSORS

LTS

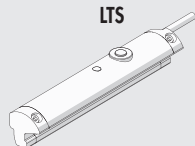

For technical data and usage strokes see **chapter A6**.