

IN-LINE QUICK-EXHAUST VALVE WITH REGULATED EXHAUST SERIES VSRR L

**METAL
WORK**[®]
P N E U M A T I C

The VSRR L quick-exhaust valve with regulated exhaust belongs to the LINE ON LINE[®] family of products and can be linked in series or in parallel to all the other products.

It comes in a version for pipe-pipe connection, which includes two push-in fittings, and a version for thread-pipe connection, which includes a nickel-plated brass taper thread and push-in fitting.

The main feature of these valves is that the discharge flow can be adjusted via a pin regulator. This allows you to control the speed of the actuator connected to the valve, giving a higher speed than with an MRF regulator.



TECHNICAL DATA		Ø 4 (Ø5/32")	Ø 6	Ø 8 (Ø5/16")
Max. operating pressure	MPa		1	
	bar		10	
	psi		145	
Temperature range	°C		-20 to +60	
	°F		-4 to +140	
Max flow rate on regulation at 6.3 bar ΔP 1 bar	Nl/min	50	270	400
Flow rate on exhaust at 6.3 bar	Nl/min	170	460	960
Adjustment		Manual or using a screwdriver		
Internal system		Tapered needle		
Recommended pipe		Rilsan PA 11 - Nylon 6 - Polyamide 12 - Polypropylene		
Fluid		Lubricated or unlubricated filtered compressed air; if used, must be continuous		
Compatibility with oils		See chapter Z1		

COMPONENTS

- ① Technopolymer body
- ② Nickel-plated brass seal support
- ③ NBR gasket
- ④ Brass adjusting needle
- ⑤ Nickel-plated brass needle ring nut
- ⑥ Nickel-plated brass wall fixing ring nut
- ⑦ NBR seal
- ⑧ Technopolymer spring ring
- ⑨ Stainless steel clip-on spring
- ⑩ Technopolymer stop bushing
- ⑪ Technopolymer release bushing
- ⑫ Sintered bronze silencer

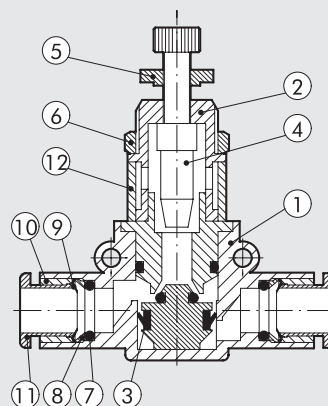

ASSEMBLY OPTIONS

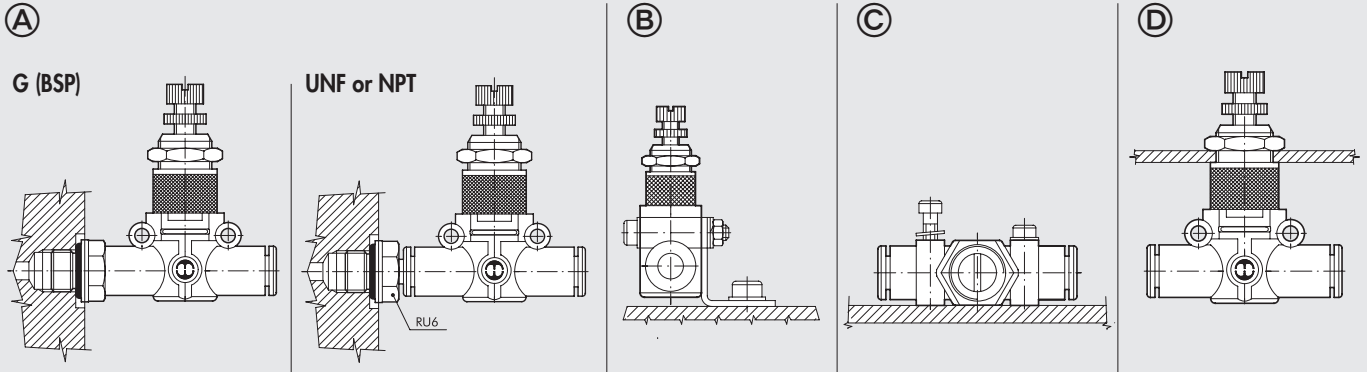

How to mount the VSRR L:

- Fig. **A** **G (BSP)**: With the male threaded port it is possible to mount the VSRR L straight onto the actuator or the control valve.
UNF or NPT: Adding a RU6 fitting, with his male UNF or NPT thread, it is possible to mount the VSRR L straight on to the actuator or the control valve.
- Fig. **B** Fixing to the plate with the special SQU L bracket.
- Fig. **C** There are two robust rings on the plastic body for fixing the VSRR L straight onto the wall.
- Fig. **D** The ring nut is screwed onto the threaded metal part of the VSRR L body for panel mounting.

EXHAUST FLOW CHARTS VSRR L

VSRR L Ø 4 (Ø5/32")

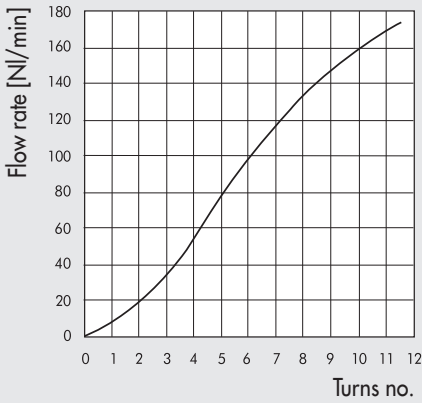

VSRR L Ø 6

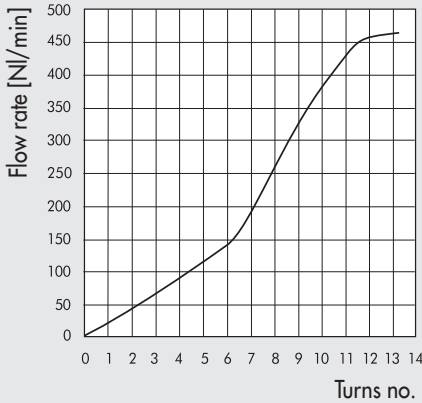

VSRR L Ø 8 (Ø5/16")

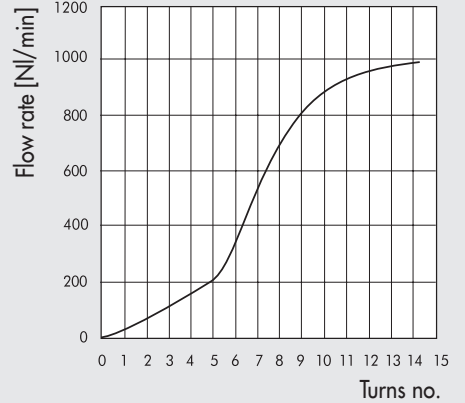

VSRR L PIPE - PIPE

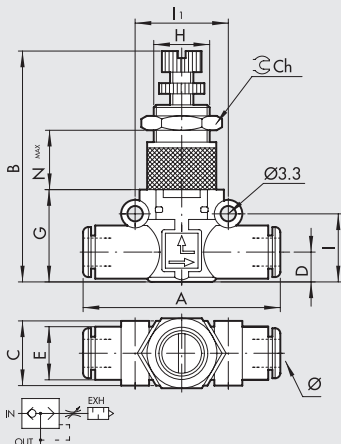

Code	Ref.	Ø	A	B	C	D	E	G	H	I	II	Ch	Nmax
9063501	VSRR L Ø4-Ø4	4 ▲	42	39.5-43.5	10.7	5.6	10	17.5	M9x0.75	12.8	16	11	11.5
9063516	VSRR L Ø6-Ø6	6	49.4	47-52	14.7	6.4	11.4	20	M12x0.75	14.6	20	15	15.5
9063524	VSRR L Ø8-Ø8	8 ▲	57.3	56-61.2	18.7	9.1	13.8	26	M15x1	18.7	24	17	18.5

▲ Ø4 = Ø5/32"; Ø8 = Ø5/16"

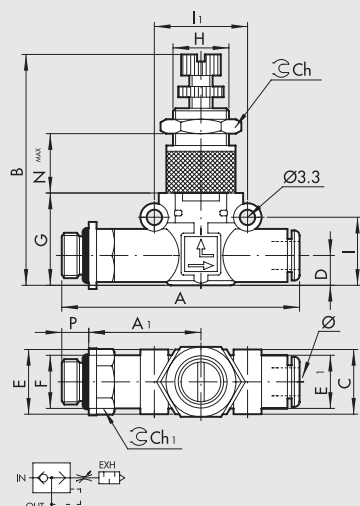
VSRR L G (BSP) THREAD - PIPE

Code	Ref.	F	Ø	P	A	A1	B	C	D	E	E1	G	H	I	I1	Ch	Ch1	Nmax
9063601	VSRR LM5-Ø4	M5	4▲	4	47.7	22.7	39.5-43.5	10.7	5.6	9.9	10	17.5	M9x0.75	12.8	16	11	9	11.5
9063602	VSRR L1/8-Ø4	1/8	4▲	6	51.6	24.6	39.5-43.5	10.7	5.6	14	10	17.5	M9x0.75	12.8	16	11	12	11.5
9063608	VSRR L1/8-Ø6	1/8	6	6	58.5	27.8	47-52	14.7	6.4	14	11.4	20	M12x0.75	14.6	20	15	12	15.5
9063609	VSRR L1/4-Ø6	1/4	6	8	61.5	28.8	47-52	14.7	6.4	18	11.4	20	M12x0.75	14.6	20	15	14	15.5
9063610	VSRR L1/8-Ø8	1/8	8▲	6	66.2	31.8	56-61.2	18.7	9.1	15	13.8	26	M15x1	18.7	26	17	14	18.5
9063611	VSRR L1/4-Ø8	1/4	8▲	8	70.6	34.2	56-61.2	18.7	9.1	18	13.8	26	M15x1	18.7	26	17	14	18.5
9063612	VSRR L3/8-Ø8	3/8	8▲	9	72.2	34.8	56-61.2	18.7	9.1	22	13.8	26	M15x1	18.7	26	17	17	18.5

▲ Ø4 = Ø5/32"; Ø8 = Ø5/16"

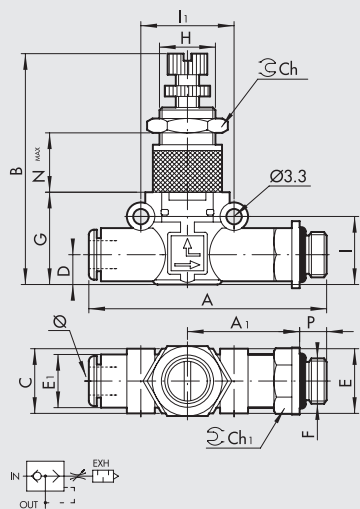
VSRR L PIPE - G (BSP) THREAD

Code	Ref.	Ø	F	P	A	A1	B	C	D	E	E1	G	H	I	I1	Ch	Ch1	Nmax
9063701	VSRR LØ4-M5	4▲	M5	4	47.7	22.7	39.5-43.5	10.7	5.6	9.9	10	17.5	M9x0.75	12.8	16	11	9	11.5
9063702	VSRR LØ4-1/8	4▲	1/8	6	51.6	24.6	39.5-43.5	10.7	5.6	14	10	17.5	M9x0.75	12.8	16	11	12	11.5
9063708	VSRR LØ6-1/8	6	1/8	6	58.5	27.8	47-52	14.7	6.4	14	11.4	20	M12x0.75	14.6	20	15	12	15.5
9063709	VSRR LØ6-1/4	6	1/4	8	61.5	28.8	47-52	14.7	6.4	18	11.4	20	M12x0.75	14.6	20	15	14	15.5
9063710	VSRR LØ8-1/8	8▲	1/8	6	66.2	31.8	56-61.2	18.7	9.1	15	13.8	26	M15x1	18.7	26	17	14	18.5
9063711	VSRR LØ8-1/4	8▲	1/4	8	70.6	34.2	56-61.2	18.7	9.1	18	13.8	26	M15x1	18.7	26	17	14	18.5
9063712	VSRR LØ8-3/8	8▲	3/8	9	72.2	34.8	56-61.2	18.7	9.1	22	13.8	26	M15x1	18.7	26	17	17	18.5

▲ Ø4 = Ø5/32"; Ø8 = Ø5/16"

NOTES