

Holder system

HTR-A0 VE HMK

Part no...:10.07.10.50037

<https://www.schmalz.com/10.07.10.50037>

Home > Vacuum Technology for Automation > Vacuum Components > Mounting Elements > Hose Management Kit HMK > HTR-A0 VE HMK

Holder system



External diameter D: 35 mm

Length L: 460 mm

Shape: Vertical

Construction use: Hose management set

Design Data

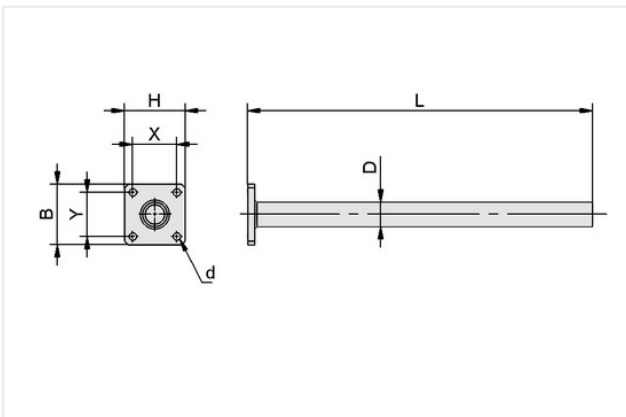

Attribute	Value
B	82.50 mm
D	35 mm
d	10 mm
H	82.50 mm
L	460 mm
Distance	60 mm
Distance Y	60 mm

Contact Schmalz

Schmalz UK Limited | Unit 2 Woodrow Business Centre, Woodrow Way, Irlam, Manchester M44 6NN, Great Britain | +44 161 243 4642 | Page 1 from 1
schmalz@schmalz.co.uk