

Hose holder

HTR-SL-102-UB-HMK

Part no...:10.07.10.50033

<https://www.schmalz.com/10.07.10.50033>

Home > Vacuum Technology for Automation > Vacuum Components > Mounting Elements > Hose Management Kit HMK > HTR-SL-102-UB-HMK

Hose holder



Mounting: U-bracket

Length L: 155 mm

Construction use: Hose management set

Design Data

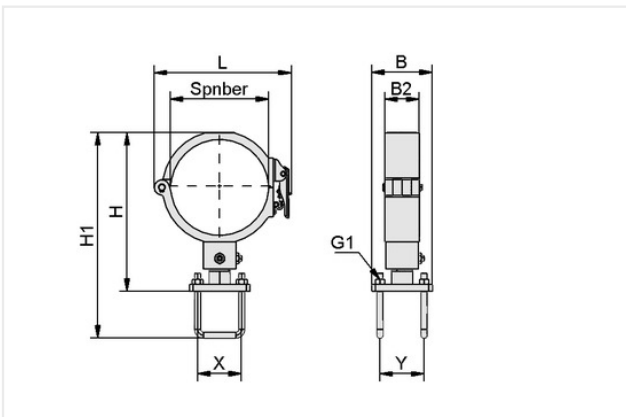

Attribute	Value
B	82.50 mm
B2	47 mm
H	184.50 mm
H1	248 mm
L	155 mm
Distance	60 mm
Distance Y	60 mm

Contact Schmalz

Schmalz UK Limited | Unit 2 Woodrow Business Centre, Woodrow Way, Irlam, Manchester M44 6NN, Great Britain | +44 161 243 4642 | Page 1 from 1
schmalz@schmalz.co.uk