

Hose mounting (round)

SCHL-AUFN 102x67 HMK

Part no...:10.07.10.50035

<https://www.schmalz.com/10.07.10.50035>

Home > Vacuum Technology for Automation > Vacuum Components > Mounting Elements > Hose Management Kit HMK > SCHL-AUFN 102x67 HMK

Hose mounting (round)



External diameter D: 102 mm

Length L: 67 mm

Construction use: Hose management set

Design Data

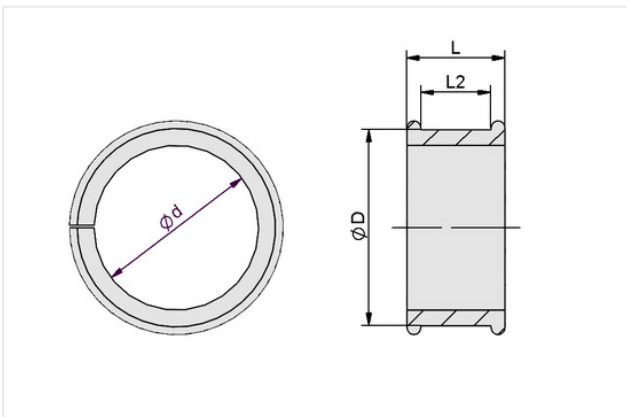

Attribute	Value
D	102 mm
d	85 mm
L	67 mm
L2	48 mm

Contact Schmalz

Schmalz UK Limited | Unit 2 Woodrow Business Centre, Woodrow Way, Irlam, Manchester M44 6NN, Great Britain | +44 161 243 4642 | Page 1 from 1
schmalz@schmalz.co.uk